

the MILLION-DOLLAR BEND

December 19, 1916	Turret Attachment	2,063,235	December 8,
November 15, 1917	Adjustable Drill Head	2,663,236	December 8,
July 15, 1919	Sheet Metal Device		
July 12, 1927	Machine for Making Radio Tubes	2,078,630	April 27, 1937
December 16, 1919	Hot Swaging Machine	2,087,104	July 15, 1937
April 27, 1920	Filament-Winding Machine	2,098,147	September 11,
April 27, 1920	Machine for Making Filament		
	Supports	(Des.) 116,840	September 26,
April 27, 1920	Machine	1,000,617	February 11,
January 6, 1925			December 16,
September 1,			March 16, 194
July 12,			October 15, 19
August			September 12,
January			July 7, 19
January			January 21, 19
June 6,			January 1947
February 1,			June 10, 1947
March 5, 1929			July 27, 1918
December 24, 1929	Stem-making	2,447,568	August 24, 19
August 18, 1931	Seal Exhaust Machine		
October 20, 1931	Disc Valve for Burners	2,447,569	August 24, 19
April 12, 1932	Burner	2,447,570	August 24, 194
July 12, 1932	Bead Machine	2,470,923	May 24, 1949
August 30, 1932	Grid Winder	2,534,547	December 10,
September 13, 1932	Beading Head Machine		
November 21, 1933	Sealing-Off and Dumping Device	2,553,135	May 15, 1951

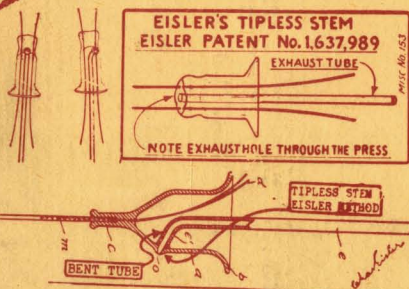

Two types of tipless stems patented by Eisler. Eisler's bent-tube exhaust method, successfully defended in court against the cartel, has been credited with saving the independent lamp-makers from ruin.

THE AUTOBIOGRAPHY OF THE BENEFACTOR
OF THE RADIO TUBE AND LAMP INDUSTRY

CHARLES EISLER, M. E., D. Sc.

THE MILLION - DOLLAR BEND

THE AUTOBIOGRAPHY OF THE BENEFACTOR
OF THE RADIO TUBE AND LAMP INDUSTRY

CHARLES EISLER, M.E., D.SC.

THE story of rags to riches is usually a fascinating one. But it is all the more so when in the plainest of language and without pretensions the protagonist describes his failures as well as his successes and shares with the reader an amazing memory for intimate detail. Such is Dr. Eisler's autobiography, a chronicle that is far more than a personal account of a rewarding life; for his career as a great technological figure is likewise the story of a successful episode in American initiative to resist the unremitting pressures exerted by the giant companies seeking exclusive prerogatives in the economic field.

When Charles Eisler landed at Ellis Island in 1904 his patrimony consisted of little more than his technical skills and inventiveness. Yet the practical application of these priceless personal commodities enabled him in a matter of years to attain a position of prominence in his chosen field equalled by few men who preceded him. His bent-tube exhaust method, so valuable to the incandescent lamp industry, was truly a "million-dollar bend."

There were obstacles this Hungarian immigrant had to surmount, as there were for every immigrant, but Eisler was equal to the challenge. Because he worked for the cartel, the patents of many of his early inventions were assigned to the company; and when Eisler left to start his own company, the Eisler Engineering Company of Newark, New Jersey, he found himself the defendant in a patent litigation brought by the cartel, a litigation, ironically enough, that shaped the future

(continued on back flap)

Buss. Riv

DP

95r

To MR. ORR

With best wishes from

Charles Eiler
The author

Newark, N.J. Nov. 1st 1966

No. #1135

To: Mr. John T. Orr
With compliments and best
wishes from the author

Charles Eiler

I hope you will find my
book interesting as well as
amusing. It may recall a
few familiar incidents and
fond recollections of your
own.

the
**MILLION - DOLLAR
BEND**

THE AUTOBIOGRAPHY OF THE BENEFACTOR
OF THE RADIO TUBE AND LAMP INDUSTRY

CHARLES EISLER, M. E., D. Sc.



THE WILLIAM-FREDERICK PRESS

NEW YORK

1960

MANUFACTURED IN THE UNITED STATES OF AMERICA

COPYRIGHT© 1960 BY CHARLES EISLER

Library of Congress Catalog Card Number : 60-11909

THE WILLIAM - FREDERICK PRESS

391 EAST 149TH STREET

NEW YORK 55, N.Y.

CONTENTS

PREFACE	1
INTRODUCTION	3
1. <i>THE EARLY YEARS</i>	7
2. <i>A CAREER BEGINS</i>	26
3. <i>ON MY OWN</i>	41
4. <i>A NEW LAND</i>	55
5. <i>MAKING PROGRESS</i>	66
6. <i>I TRY AVIATION</i>	83
7. <i>A VISIT HOME</i>	90
8. <i>I GET MARRIED</i>	96
9. <i>A FRESH START</i>	101
10. <i>THE FAMILY GROWS</i>	108
11. <i>THE BIG STEP</i>	115
12. <i>AT GRIPS WITH THE OCTOPUS</i>	122
13. <i>IN THE PRESS</i>	135
14. <i>PROSPERITY DE LUXE</i>	159
15. <i>VISITS TO RUSSIA</i>	177
16. <i>GLIMPSSES OF MY NATIVE HUNGARY</i>	192
17. <i>GERMANY AND FRANCE</i>	203
18. <i>BEHIND THE IRON CURTAIN</i>	220
19. <i>UNHAPPY EXPERIENCES AND HAPPY ENDINGS</i>	225
20. <i>THE "HAPPY CENTURY"</i>	248
APPENDIX	255

PREFACE

HAVING SPENT fifty-five years in my adopted country, thirty-eight of them as owner of the Eisler Engineering Company of Newark, New Jersey, now at the age of seventy-five I take this opportunity to thank all my friends, not only in the United States but all over the world, for their cooperation, support and friendship in the past. My inventions have proved to be of great benefit to them, especially my successful litigation that made it possible for the lamp and radio manufacturers here and elsewhere in the world to remain in business. Wherever, whenever, and to whomever my patents were of value, they were always free to those who would help the industry at large. Today, in retrospect, I feel I was successful in establishing some degree of friendly business relations all over the world.

After hard work for over fifty-five years I feel I am entitled now to a few years of rest and pleasure. I have turned over the leadership of the Eisler Engineering Company to a very capable, well-educated and hard-working young engineer, my son Charles Jr., who was trained to follow in my footsteps, and to a staff of well-seasoned mechanics and to a long-standing management. I trust that Charles Jr. will receive the same cooperation I had from all my friends and from my organization. I am leaving the Eisler Engineering Company in his hands. With the knowledge and experience he has gained in working with me, it will benefit everyone to continue to manufacture my inventions and add improvements to them for the benefit of our friends and customers.

CHARLES EISLER, M.E., D.SC.

October 1958

INTRODUCTION

(Convocation read in 1951 at Bloomfield College, Bloomfield, New Jersey, by the Rev. J. Charles McKirachan, Ph.D., of the Westminster Presbyterian Church of Bloomfield.)

CHARLES EISLER, M.E., inventor, designer and machine builder, came to the United States fifty-five years ago from Budapest, Hungary. He had worked in factories in Hungary and Germany. In the land of his adoption he found fertile soil where the seeds of mechanical genius germinated, grew and came to phenomenal fruitage. He is a representative of one of the foremost glories of the American republic. From humble origin he discovered by unflagging zeal, personal discipline and confidence in himself and his destiny the pathway to a deserved, world-wide recognition in his particular field. As a benefactor of mankind, he is one of those practical scientists who have bequeathed to his own and to succeeding generations many notable inventions to increase the production and distribution of many commodities which have enhanced the comfort, increased the happiness and enriched the outlook of countless multitudes. In a day when there has been an increasing tendency, particularly in his own field, for the small and individual inventor to be absorbed by great corporations and governmental agencies with their elaborately staffed and equipped laboratories and research facilities, Mr. Eisler has been an individual inventor and has carried forward that stalwart American tradition of private enterprise of independency of effort and personal initiative which has made our country great.

Most of his engineering education was obtained through trade schools, home study and private tutoring. He became

chief engineer of equipment for the Westinghouse Co., Bloomfield Division in 1916. In 1920 he initiated his own business by launching the Eisler Engineering Company in Newark, New Jersey. He began manufacturing machinery for the independent production of radio tubes and incandescent lamps, designing automatic lamp and radio tube-making machinery. One of his special contributions has been the fulfillment of the dream of mass production of radio tubes and incandescent lamps. Today the Eisler Engineering Company is recognized internationally as the largest firm in the making of automatic machines for the manufacture of radio tubes and incandescent lamps. Mr. Eisler himself holds over fifty patents, including inventions of sealing-in machines, exhaust machine mechanisms, stem-heads, filament coil-winding machinery, annealers and furnaces and vacuum pumps. Mr. Eisler's patented machines and inventions on radio component parts have made it possible for many independent companies to continue operating in spite of the unremitting pressures exerted by the giant companies seeking exclusive prerogatives in this field. Incandescent lamp and radio tube-makers in the United States and all parts of Europe, England, China and Japan engaged in this same battle. As a saga of an independent spirit, an undiscourageable fighter for individual rights and for free enterprise in the United States, the name Charles Eisler is known to incandescent lamp and tube-makers in every part of the world. His company catalog is said to be the "bible" of these industries in every country.

Mr. Eisler is a member of the American Society of Mechanical Engineers; he is a licensed professional engineer of the State of New Jersey and is the past president of the Resistance Welders Manufacturers Association of the United States. In 1934 the independent lamp manufacturers of the United States presented him with a plaque in recognition of his outstanding accomplishments, citing among other achievements that "without his able assistance many of our present-day accomplishments would have been impossible." In 1945 the same association memorialized him, saying, "Mr. Eisler's patents have helped to keep the incandescent lamp

and radio tube industries going for many years. Without his patents most of the companies in these industries would not have been able to continue."

Bloomfield College and Seminary has long ministered to the education of Hungarians migrating to America and has been noteworthy in providing opportunities for the training of ministers for the Hungarian-speaking churches of this land. Mr. Eisler's interest in Bloomfield College and Seminary has taken the form of a special interest in the creation of Dikovics House, a place of social fellowship, recreation and activities at Bloomfield College and Seminary. Dikovics House is made possible largely through the generosity of Charles Eisler.

1 1

Charles Eisler, for the unusual degree to which you have been a part of, embraced and furthered those fundamental spiritual, moral, industrial and scientific principles close to the heart of this institution of higher learning, Christian culture, training for the ministry, and strengthening the Church of Jesus Christ, I, on behalf of the Board of Directors, take pleasure in presenting you to be the recipient of the degree of Doctor of Science.

1. THE EARLY YEARS

THE WORLD began for me in 1884 in Hungary, where the Eisler family lived on the premises of a large brick-making factory called *Chillag-Hegyí Gőz Téglagyár*—about thirteen miles from Budapest. I was the second son in what was to be a family of nine children, eight of them boys. My parents, Adolf and Helen, both natives of Hungary, were married in Budapest in 1880; Adolf was twenty-eight at the time, Helen seventeen. At the wedding, Father promised Mother a honeymoon that would last for fifty years. He was not wrong; they both died more than fifty-one years later.



The Eisler home for twenty years, 1890-1910. *Center*: The main house. *Left*: The outdoor baking oven. *Right*: The summer house (*szalatti*), next to the main water supply; the tool shed and workshop behind the well.

In his younger days, Father was a fermentation expert, but because this profession took him away from home quite a bit—a circumstance Mother did not favor—he changed his position to one which enabled him to remain with the family.

Mother was a refined, soft-spoken, good-natured woman. She loved to read—Zola, Schiller, Goethe or whatever was

offered by the "reader" who went from house to house each week. She was a very soft-hearted woman; it did not take much to bring tears to her eyes. When in later years she wrote to me in the United States her letters always were stained with tears which had fallen in Hungary. But despite her sentimental nature, she, like Father, applied the strap to us children whenever it was required; although not used often, it was always kept handy.

Father was very strict with us. He looked over all our schoolwork; the doors were locked at 9 P.M. and everyone had to be in, regardless of age. Each evening there was inspection period for the next day: shoes had to be shined, clothing pressed and hands scrubbed, fingernails and toenails clipped and cleaned. He was as strict as an army sergeant. At dinner the greatest discipline was observed, and that meant no talk while eating. There was no back talk to Father at any time. As a result, the Eisler children were always well mannered and well behaved; they knew what respect meant, especially for older people.

1 1

One of my earliest memories takes me back to 1891, when I was seven. A dam had broken and the Danube flooded the countryside, our home included. Using the wash trough as a boat, I rowed back to the house with my younger brother to



The Danube on the rampage, as young Charles pilots his wash-trough craft through the swirling currents around the flooded Eisler home.

salvage some clothing—soaked, of course. I remember the furniture floating around inside our dwelling. When the

water finally receded six days later, our back yard was full of all kinds of fish. It was great fun catching them from out of the mud with the help of the neighborhood kids, but once indoors all that mud and fish didn't look so appealing. For a long time we had to stay out of our house because it was too damp to live in. Most of the furniture separated at the joints where it had been glued together and much of it was completely ruined. The only ones who enjoyed themselves that time were the ducks.

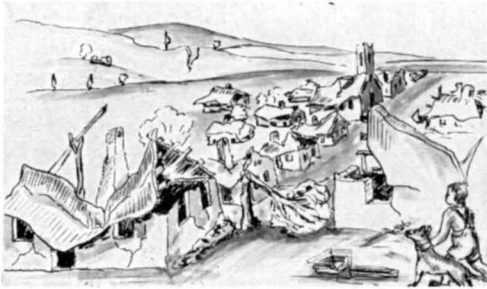

Earthquake in Budapest's O-Buda sector in 1891 caused havoc.

When I was six or seven years old there was a tremendous earthquake near where we lived. Many houses disappeared in the cavities the quake opened in the mountains. Quite a number of people were killed—swallowed up completely—but we were not affected by it at all. (This was long before my wife found the horseshoe, and she cannot give the good luck charm the credit for our escape.) I had a little dog, and he barked for a long time before the earthquake occurred. My mother tried to tell me that the dog had sensed the earthquake coming and that was why he barked.

I was the worst kid, according to my poor mother; not bad in a sense but full of fun and always busy with something. I was never lonesome. After school in the summertime, if my mother wanted me she had to send someone to the stream or in the field, because the gang was bathing and I was always there or on someone's farm in the neighborhood. In the winter I would be skating on the old pond on wooden skates made by us boys. We made our own sleds because we had

no money to buy any with. Every boy had a homemade one and it gave him just as much fun.

My pets were a cat, two or three field turtles and four or five frogs. I always had what we called a weather-signaling or weather-indicating frog. The old Hungarian saying was, if the frog is up on the ladder out of the water there will be sunshine; if the frog is below in the water it indicates stormy weather, and most likely rain. Of course this held good only for the summer months. In the winter I would keep my frogs in sand in the cellar. My biggest job was feeding the frogs with flies of all kinds; they picked them up as fast as I put them in the jar.

My favorite pet was a little cat, with whom I shared many a mischievous moment. I would tie half nut shells on its legs at night and send it into my father's bedroom when he was asleep. Walking around cautiously at first, then hammering away with its legs, trying to remove the shells, the cat sounded like a couple of noisy burglars. Fortunately for me, on these occasions Father kept his sense of humor, even when



Above: The Eisler weather-signaling frogs. *Right:* Sampling the milk supply in the pantry (*schpeiz*).



I would place a jar of crickets under his bed at night. He showed admirable self-control.

I was very fond of milk; often when Mother left the house I would take up a straw and sip some of the milk from the large pan she always kept in the kitchen. If I took a noticeable amount and Mother was about to find out, I would quickly smear a little cream on the cat's whiskers. For many years Mother regularly spanked the cat for stealing milk. The poor animal never got a taste of milk but she took the blame for my mischief.

When the cat died, Mother asked me to bury it on the shore of the Danube, because "kitty" was given to us by a Swabian when we were vacationing in his house. That Sunday I put the body in a paper bag and took the train. My fellow passengers were a family of five, going on a picnic. The children were constantly crying: "Mommy, give me a ham sandwich!" "No!" she replied. "You must wait until noon."

Arriving at my destination, I took the paper bag from the shelf, got off the train and went down to the shore to dig a nice grave for the cat. Before I buried her, I wanted to give "kitty" a farewell look. I almost fainted when I found a half-dozen ham sandwiches in the bag. I was so shocked that I had to calm down my nerves; then I ate all the sandwiches.

Fishing for frogs.

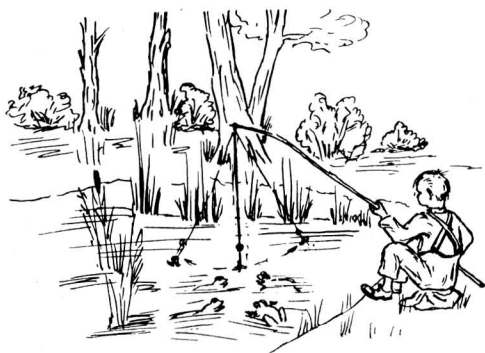

I was a pretty good frog-catcher with homemade tackle. But I was not allowed to bring home the beautiful big, fat,

green frogs; my mother nearly fainted when she saw a frog. I had to go from house to house with a dozen to find an Italian who was willing to take them. I never ate frogs as a boy. It has taken me thirty years to learn to eat frogs' legs in a Paris restaurant. While I had plenty of them for nothing I had no taste for them; later, when they were very expensive, I acquired a taste for frogs. Oh, human nature.

For several summers, starting when I was about eight, my mother would send me to the country for a few weeks, in exchange for a German boy who would stay at our house and learn the "city life." I was always eager for this switch in routine, but not the German boy. When his mother would bring him over and prepare to take me back with her, he would loudly lament the situation. His mother would tell him that Mrs. Eisler baked such fine white milk bread for his coffee, but he yelled that he would rather eat black bread at home than white bread at Mrs. Eisler's.



Mother Eisler baking the weekly bread.

This brings to mind one of the great pleasures of my childhood—the baking and eating of bread in the Eisler house—

hold. The present generation in this country cannot know or even imagine what bread meant in Hungary when I was a boy. Handling bread was like holding a diamond in your hands. Once a week on bread-baking day a holiday spirit prevailed in our house. I remember the rule: the newly made bread could not be touched until all the old bread was eaten. Toward the end of the week the old bread was so hard that you had to dunk it in hot soup or coffee just to be able to bite into it, much less swallow it, but we saw to it that there was no old bread around when the fresh bread was ready.

The biggest treat was the *lepény*, the leftover dough which had been scraped off the side of the wooden trough; it was always baked first and was considered a delicacy when eaten hot with jam, butter or fat. One of us would always run to the factory with a fresh piece of *lepény* so that Father could have some while it was still hot.

The proper temperature in the baking oven was the most important factor in the baking of wholesome, tasty bread. When one considers that no heat-reading instruments, heat regulators or temperature controls were in use, the skill of the "old-fashioned" mothers who did the baking for their family can be appreciated. My mother had her own temperature control and checking device; it was of special design. She would moisten her finger on her tongue, touch the heated floor of the oven, put the finger to her ear as she said, "*Jo meleg*" (It's good and hot), and in would go the dough on a long-handled wooden shovel. After just the right amount of time, out came the bread, baked to perfection. To this day I have not lost the feeling of exhilaration whenever I smell fresh-baked bread.

The bread was always under lock and key in the kitchen cabinet; otherwise we kids would probably have eaten a week's supply in two days. After running around in the woods near the house and swimming in the creek or the Danube, when we came home we could have eaten not one loaf of bread only but a *kilo* of bologna as well, if Mother could have included it, and a good supper right after.

My mother used to say, "*Kinder, ihr isst mich arm*" (Kids, you are eating me poor). And then she told us we would

have to go to work soon, because one father could not earn enough to support nine children. So as soon as we grew up we all managed to earn a little. My job in the summer was helping neighbors: painting, sweeping, picking fruit, cutting wood for the winter or taking parcels here and there. We all worked according to our ability. I was a good cook's helper; very often I went to neighbors to help in the kitchen. This experience was a lot of help to me in later years.

On account of the large family we had, my mother always preserved a large quantity of food every summer. Especially important was the tomato sauce, of which we usually put away 300 or 400 bottles; nothing is cooked in Hungary without tomatoes. Our job was to keep the fire going and run the tomato sauce through the sieve to keep the pits out. Every boy was responsible for attending to something. One week my mother would preserve such items as tomatoes, cucumbers and green peppers; then the next week she would start on preserving fruit. The most important preserve item was plums, better known as *lekvár*. Plums generally served an important purpose. When there was nothing else in the house, a spread of plum preserve on bread filled the bill nicely.



At preserving time each year, Mother would put up over 300 bottles of tomatoes for soups and cooking.

Of course, our house was not unique in this respect; every house did the same thing in the summer, which served to keep most of the families going. Every family knew the importance of putting something away for the winter months. Pickling was also practiced extensively. In our house, pickles

and peppers and green tomatoes were put away by the barrelful. The barrels were always empty by spring. And, of course, my father also preserved sauerkraut, which was another big item in our house.

Washday in our family was always a big day, with enough washing to support a good-sized laundry. It started at five o'clock in the morning and ended at eight at night. And this went on every second week. The interesting part, as I look back on it, was the tremendous undertaking it was to sort out the clothing and prepare for washing and ironing for such a big gang. There was a wash house arranged for that purpose in back of our home. The wash lady had to have a drink of liquor before starting to work. The water had to be hot and everything properly segregated before she started her work. My dad would get up at four in the morning, start the fire, get up the hot water and have her drink of schnapps and a piece of fresh bread ready. She would delicately take a little bite with every sip. Of course it was hard work from 5 A.M. to 8 P.M. The wash lady received three good meals a day and a day's pay. She was considered a specialist.



The bitter cold of the Hungarian winter is not exaggerated by those who describe it. The mighty Danube would freeze to a depth of three feet, so that even the heavy wagons could cross it. Legends told of the many groups of travelers who walked on the frozen Danube with their horses and wagons, some of which would suddenly disappear when the ice began to move unexpectedly. Hundreds of people were said to have lost their lives in this manner. I remember seeing large parties, with music, dancing and entertainment, held out in the middle of the frozen river. It was sometimes the middle of May before ships could navigate the Danube, and often the ice needed dynamiting to help the melting along. When the ice finally did start moving, it would carry everything that stood in its way—houses, water mills, even small bridges. I can still remember the rumbling noise produced by the moving ice—it would go on ominously for days.

Wolves were plentiful in Hungary, and we heard many



The wash lady earned her money at the Eislers'.



Small items were rolled on the *kézi mángolo* (hand mangle).

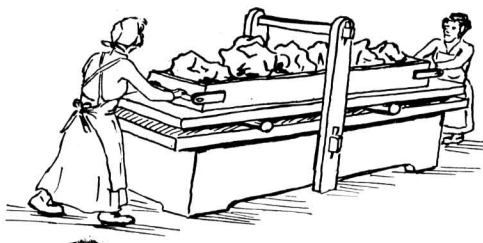

The *nehéz mángolo* (heavy roller), a popular piece of equipment in Hungarian homes. The table was weighted with heavy stones to hold it in place as the clothing was pulled back and forth.

bloodcurdling stories about them. Yet according to some foresters the wolf never attacks a human being and people are needlessly afraid of the "big bad wolf." But no one could tell that to my mother. One day in midwinter she had started to open the chicken coop when suddenly two wolves appeared and jumped at her. Luckily she had a broom in her hand—it probably saved her life in the furious fight which ensued. Her head, hand, arm and legs were bitten before she could manage to fend them off. We lost half our chickens and geese that day to the "harmless" wolves.



The "harmless" wolf in the chicken pen.

In the cold winter months the hungry and shelterless wolf is indeed desperate; he knows no fear, and will stop at nothing in order to get food. I recall the story of a group of workers from the factory who went into the woods with their families on a very cold afternoon in December to cut down Christmas trees. After the sleigh was loaded and they had started for home, the two horses were suddenly attacked by a pack of fifteen wolves. Again and again they jumped on the terrorized horses, biting them viciously. The people—about ten men, women and children—shouted and cried for help. They were at a loss as to what to do. Wolves surrounded the sleigh, a few running alongside and jumping at the horses, some in front, and a pack in back of the sleigh, some even jumping into the group of people, howling, barking and baring their teeth. The group had to restrain an old man who wanted to jump out and sacrifice himself to give the rest of the party a chance to get away while the wolves were busy with him.

Finally, in all the excitement and panic, one of the women apparently lost control and quick as a flash she threw her two-year-old baby to the hungry wolves. Aban-

doing the sleigh, the entire pack fell upon the child. Continuing then unmolested, the group was soon met by several laborers who had come from the plant to search for them. The men shouting, the women crying, they told their story, and then the men, armed with picks and shovels, went to look for some trace of the little girl. They found only a few pieces of torn rags where she had been devoured. Later the hysterical mother was accused by her husband of using this occasion to get rid of the child she did not want. It was indeed a tragedy—all the more ironic because usually the group took along a dead lamb or some chickens or old meat with which to distract the wolves in case of an attack. This time they had nothing to offer—so they had to sacrifice a little child.

/ /

My older brother George and I walked three and a half miles to school every morning and back in the evening. Mother packed sandwiches for us which were supposed to last all day, but most of the time we ate them before we got to school, having worked up an appetite walking. Of course we did not mention this at home, and soon one of the teachers reported to my mother that we ate no lunch in school, and after that my parents arranged for us to get a hot meal every day in a small restaurant near the school.



En route to school in a snowstorm.

We would leave the house at 6 A.M., often in the pitch dark with lanterns belted around us, guided in the winter by the

reflected light on the snow. Although we were the only boys coming from so far away, we were always the first ones in class. Everybody living along the road knew the two boys walking to school; they were able to tell the time of day by our passing. Rain, shine, snow or hail, we had excellent attendance records, thanks to Mother's ambition to see her flock get ahead in the world.

The teacher always held us up as examples to the habitual latecomers. "Look, boys, Charles and George walk two hours to school. They are always on time while you live here and come late!"

Father left the house even earlier. He started every morning at 5 A.M. and came home after 9 P.M. So while we lived in the factory, we only saw him on Sundays. He left in the dark, always making it his business to start with the men and come home with the men. If daybreak had come at four o'clock in the morning, the factory would have started at that time. Breakfast was sent to his office at seven-thirty. At ten o'clock he had *Freuhsteuck*, (a bite) and lunch was taken to him at twelve-thirty. Another "bite" at six, and dinner at nine. Ten-thirty was his bedtime. For us long-distance walkers (my brother and myself) bedtime was at eight.

We knew every fruit tree along the road, and in summer we had more fruit inside our bags than books. In fact, we turned down many a ride to or from school because we liked the idea of helping ourselves to cherries, plums, apples and grapes along the way. Of course in the winter we would have welcomed a lift, especially in the morning, but the farmers' wagons were always full.

We were plenty scared on that dark road, mostly since the farmers reported seeing wolves in the vicinity. We were told that wolves were afraid of fire, so we carried newspapers with us at all times. As soon as we glimpsed a stray dog, we started burning the papers. We never did see a wolf on that road, but we did see bears, foxes, wild boars, snakes and owls, in addition to lots of things that were not there.

1 1

One of my favorite schoolteachers would often take his

bicycle and gun and go hunting in his spare time. One Monday he did not show up for his classes. Since we all knew he went hunting in the nearby mountain, several of the boys and other teachers went to search for him. We had not gone far into the woods when we came upon a few wild boars hovering about a spot where the hunter had obviously climbed a tree. The affair was reconstructed and it was deduced that the fellow was surprised by the boars almost as soon as he had entered the forest, and had time only to climb a nearby tree. While he waited there for help, the animals chewed away at the stump. Finally the tree toppled over and he fell to the ground. By the time we arrived, only bones and torn clothes could be found. Even his bicycle tires were chewed up. The bones were taken back to the city for examination, along with the remnants of clothing, and it was established positively that the victim was our poor teacher.

Another interesting and unusual occurrence comes to mind. We were informed one day that a classmate—a girl about eleven—had died, and I was invited to attend the funeral that Sunday. It turned out to be quite an event. By chance, I was the first one to enter the bedroom where she was "laid out." As I walked into the room, to my amazement the girl was sitting up in her coffin: her eyes were open, staring at me, but she was motionless, as if she were asleep in a sitting position. I ran out to the yard, shouting what I



The "corpse" was very much alive.

had just seen. Naturally, this created one of the greatest commotions I have ever witnessed. The folks were overjoyed to see her back from her "temporary journey." The doctor was called, and he put the dazed girl to bed. And instead of a funeral, a party was given. I remember the table loaded with smoked meats and drinks; the music played and we all danced in a large kitchen. The presumed dead girl looked on, sitting up in bed but not saying a word, still half-dazed. After the party everyone shook hands with her. Three weeks later she was back in school—the most popular girl in her class and the talk of the little village.

There were four methods of punishment in school: (1) kneeling, (2) kneeling on corn seeds, (3) strokes with the thin cane on the finger-tops, and (4) strokes on the backside. Janko, a husky peasant boy, a little devil, had the worst record. One day when he was condemned again for six strokes on the backside, he looked suspiciously padded from the waist down. "Take off your trousers!" commanded the teacher, with the cane in his hand. When Janko took off his trousers, the teacher commanded again: "Take off your *second* trousers!" Though it was a hot summer day, under the second trousers Janko wore a little cushion.



The pumpkin was introduced to the modern American diet only recently. Doctors discovered that the tasteful, vitamin-rich pumpkin has a very good effect on the bowels. Hungarian peasants knew this for many hundred years. Back in Asia the giant pumpkin was the main dish of the poorest people. Janko, who was barefooted even during winters, appeared in the school with a book-sized baked pumpkin hanging on a string from his neck. It was his lunch. But he liked variety too. I once lost a bet with him. For one *kreuzer* he ate a big, fat, live silkworm. He was a brave boy. Later I learned that during World War I he was killed on the battlefield, a decorated hero.

Our offenses included scrawling obscene words and drawing on the wooden fences with chalk. The usual old-fashioned poster stood before the barber shop: a dandy with

fancily combed hair, sharply curved mustache and nicely shaped beard. One early dawn someone secretly painted over the portrait. The hairy dandy became entirely bald, his dignified mustache and beard summarily shorn. Now, after sixty years, I am willing to admit being the culprit.

Children are the same in every corner of the world. I saw here in the United States the same obscene words and drawings on the walls. Let a large advertisement appear in the subway station, the next day the beautiful girl on it sports a neat, curved, black mustache, and the same pencil blacks out several of her shining teeth. There is among children a deep instinct for destruction and obscenity.

Even as I write, the officials in Albany have launched a three-day conference and workshop of experts intent on framing a state policy to combat juvenile delinquency. Governor Harriman told the delegates: "I don't suppose anyone will argue that children are any worse today than they were when you and I grew up. If more of them become confused and fall into trouble, it is a reflection of the difficult times and the congested slum areas in which they live."

I agree. If juvenile delinquency was less widespread during my generation, it was due to the two factors mentioned by the governor. First, instead of the terrific tension in world politics today, we lived in the great Victorian peace period. Second, instead of the congested slum areas, our playgrounds were the open fields, the meadows, the nearby forests; we were in closer contact with nature. But I can mention two other very important factors: the warmth of the family life and our strict education. Father represented, first, authority and then love. Mother represented, first, love and then authority. Father, the strict "staff sergeant," liked to tell us tales. Mother, the soft-speaking angel, was very handy with the strap when it was required of her.

The experts at the Albany conference were unanimous in their solution: Let's guide children and teenagers in the constructive use of their free hours. Let's give them work. In my childhood we worked. Father never gave us any money we had not worked for. When I was a five-year-old, I already earned four to six *kreuzers* a day picking straw-

berries, cleaning the kitchen stove, and so on. In our back yard there was a shed which served as the boys' workshop. It was always alive with activity. We made toys for ourselves, for gifts, and even worked for others.

Parents didn't hand out lavish sums to their children for performing odd jobs around the house. It was more or less a hobby of mine to earn a few pennies here and there. While we did not charge a neighbor for grinding a knife, a stranger would be charged five *krajcar*, about five pennies. This meant grinding and sharpening every tool in the kitchen, even to straightening the teeth in an old fork and grinding a point on them. My mother was always proud of me when I fixed keys, soldered kettles and repaired stoves for neighbors. She would always spoil my business by telling me, "Károly, please do me a favor—don't make any charges for this work. They are such fine neighbors; one never knows when one needs a neighbor."

One year my father was very much discouraged at my school report in spite of the fact the he was always helping me, following my arithmetic, checking on my reading, writing and general homework. Somehow something did not click with my teacher and no matter how well I did my work, however neat it was, it never satisfied my teacher. This went on for a long time. Nevertheless I went to school every day to this same teacher from the age of ten to thirteen. I asked my father to go to the teacher and find out what he did not like about me and my schoolwork. He went to talk to my teacher and I overheard the following: "Your boy Karl will never amount to anything. Whatever he does is wrong, he is



School days in Hungary.

not the studious type of boy." I did not mind it at all that we did not get along well. I thought it had to be that way. I figured it out—after all, he cannot like everybody. My father was not at all discouraged. He knew it was not as bad as the teacher made it appear because in other classes my reports were always better.

About fifteen years later I went home to visit my folks, and I told my father I would like to meet my old teacher once again and would he come with me. I had a small box of American cigars I wanted to give him. My teacher had been promoted *Herr Direktor* of the school. We called on him and he was very glad to see us both. He asked me how I was getting along in America. I told him I was doing fine, had a good job, earned good money, and that I loved America and Americans and everything America stood for. I told him that I was studying engineering and tool-designing. He said to my father with a smile on his face, "Herr Eisler, I always told you that your boy Karl was a smart little fellow and some day he will go places and you will be proud of him." I handed him the box of cigars. After we left my father said to me. "I always told you he never meant what he said."

The same experience that I had repeated itself with my son Charles. I sent him to a very fine private school. Whenever I visited his one teacher in particular, he had about the same opinion of my son as my teacher had about me. Two or three months before graduation I visited his headmaster and told him, "Now, my boy Charles is about to finish here and, as you know, I intend to send him to college to become an engineer." The headmaster told me, "Mr. Eisler, I don't believe this boy of yours, while he is a very fine, well-behaved young man, is college material." This was some shock to me but I did not take it seriously because I had gone through this myself. I knew the dean of the school and I told him what the headmaster had told me about my son. The dean was furious. "This boy of yours is a very fine fellow, and always had a good classification. I guarantee you that he can go with his report to any college in the U.S.A."

Charles Jr. went to Stevens Institute and received his

master's degree in mechanical engineering. He went on to M.I.T. and received his master's degree in electrical engineering. After he was married and had a family he went back to Stevens for five years at night to get his metallurgical master's degree.

/ /

In school I made friends here and there, but the little group that I remember best I met in the fifth and sixth grades, when I was about thirteen. These boys and girls were malformed—some six of them were hunchbacked—and unusually short in stature. Few kids cared to associate with them, many even avoided any conversation with them—children are so often unintentionally cruel to those less fortunate than themselves. I would invite these little ones to come and play in our barn or in our woodshed, where we were always making something useful for the neighborhood. Father used to tell me, with an understanding grin, that some day I would make a good circus man, because of the abnormal children I brought into the house. Nevertheless, these kids were at least as smart as the rest of us, and they were loyal comrades. We remained friendly right up to the day I left Budapest for Germany to study engineering and work as a machinist. When they found out that I was going, they got together and purchased my tickets for the entire trip—train and steamer. I have never forgotten this, and in the succeeding years I sent them clothing, food, eyeglasses, etc., as token repayment for their generosity.

2. A CAREER BEGINS

WHEN I think back now after all these years, I remember with much gratitude Father continually preaching to all the boys that they must learn a mechanical trade. "Every king and ruler always knows a trade that he can fall back on, just in case," he would say. "So long as you have learned a trade—I don't care what it is—you can make a living in any part of the world. Nothing else is so important." I was the luckiest of the boys, because I had the best opportunity to learn a mechanical trade that I liked. Of course all of us learned a trade: four took up machine-building, one printing, one teaching, one banking, one forestry, and the girl dress-making. We all learned how to make a living.

From the time I was ten years old my attention and interest was always drawn to any machine that could work iron, steel or brass. My future was carved out on an iron-turning lathe in the factory. When I saw Mr. Kovacs, a machinist, working on the lathe making continuous turning chips, I felt it was a privilege even to pick up the chips from the lathe. When I was about eleven, on my days off from school, I would spend hours watching the lathe running; I was fascinated. One day,



Young Charles compensates for his lack of stature by standing on a stool while learning lathe operations.

Mr. Kovacs surprised me: he put me on a little stool and showed me the rudiments of operating the lathe. It looked easy. With his good instruction it did not take me long to manage simple turning; I learned quickly. Finally I was permitted to turn plain jobs, and Kovacs approved, saying, "Charlie, you made a good job."

From then on every spare minute was spent in the machine shop. I was always late for supper, and often my mother would bring my evening meal into the shop, since our home was only five minutes away. The first time she saw me running the lathe she was frightened, but she carried home the lathe chips I made. She was really proud of me.

By the time I was twelve I was receiving advanced instruction and was considered a fairly good *vas esztergalyos* (lathe hand). In fact, for a few weeks I was even earning money.

One of the lathe hands who was on piecework asked me to do some of his lathe work at night, on Sunday or whenever I could, and he would give me half of his earnings. It amounted to twenty-five cents each day. However, it did not last long—only about two or three weeks—because my father became suspicious. I had to confess when he questioned me, and he told me he did not like the idea of my helping someone to earn money on work he did not do. So I gave this up—but that did not stop me from working in the machine shop.

The factory was the center of a sizable community of two thousand. This group was made up entirely of employees—laborers and "white-collar" men and their families. Teachers and engineers were also hired to work there and conduct classes.

The company owned about seventy teams of truck horses, used for hauling bricks to Budapest or to steamers on the Danube; the white-collar men had the privilege of using these horses and wagons, which were the main form of conveyance.

The factory issued its own brass money, known as *jancsi banko*, which was not acceptable outside the plant, so that the employees had to make all their purchases in the company canteen, which sold everything—clothing, groceries, bottled

liquors and medicines. This rule, of course, applied only to the laborers. The officers were paid in regular currency. At the end of the season whatever "brass money" the workers had left would be exchanged for standard currency. This way they could take their savings home at the end of the summer, when the factory closed for the winter and they all went to Poland. A typical workman's lunch in the canteen consisted of sharp peppers (3 cents), bacon (5 cents), and bread (2 cents). Note that at 25 cents a day for a few hours' work, when one reckons the general cost of living, I was the richest twelve-year-old in the neighborhood during those few weeks I worked.



Learning to cast metals while working in a brass factory as a boy.

All brick work was out-of-doors, and since clay bricks could not be made in cold weather, the factory was closed during the winter; but in the spring the workers came from all over Europe: Poland, Austria, Rumania, Italy, Croatia, Bulgaria, Serbia, Greece and Turkey. They all quickly learned enough Hungarian to "get along," but I use the phrase advisedly. Each group kept its own customs, among which was the strong dislike for most of the other nationalities. The Serbians hated the Poles, the Turks the Greeks, the Bulgarians the Rumanians, etc. And none of them had any use for the

Hungarians. When I think back now, I realize that this mutual dislike existed mainly because of lack of proper social education. The hostile attitudes were learned from parents and other adults early in life, and it seems to me that a more pleasant world would result if children were taught tolerance and understanding of others by parents or the others who influence young minds.

Unbrotherly feelings usually showed up strongest on Saturday nights in the canteen. But the *csendörs* (state troopers) were always ready. They invariably arrived in fours—a lone *csendör* would never dare to enter the canteen. No matter how unruly the gang was, though, the *csendörs* made order.

Father was paymaster for the company and we were given our house as part of his salary arrangement. It had five rooms, and although we had no steam heat and no water, we did not know any better and so we did not miss these living essentials. In fact, we were rather fortunate compared to the general laborers, who were crowded with their families into four or five huge barracks with no facilities of any kind.

One summer there was a cholera epidemic in the plant. It started apparently from bad meat and the plant was quarantined for ninety days. No one could go out and we youngsters missed the first two months of school. There were many deaths, although no one in the Eisler family was affected.

The result of the epidemic was that the factory was sold, and we moved bag and baggage to a larger plant not far from there, where Father obtained a similar position to the one he had held. We were given a more modern home with better facilities; we now had a coal stove, hot water and, best of all, a genuine Turkish bathhouse next door. This was Father's handiwork, and it was known, admired and used by many of the neighboring officials' families. Soon there were three or four more of them built in the area.

This new factory manufactured brick- and tile-making machinery, and had some pretty modern equipment. It was not long before I became an apprentice in the machine shop. I was fourteen when the manager of the plant suggested to Father that I work half a day in the shop and half a day in

the engineering department. I followed this plan for the next three and a half years, learning the lathe, drill press, steam boiler, machine construction and general machine shop practice. I also attended the village vocational school three evenings a week, and on Sundays I studied drafting, mathematics, machine drawing and engineering. I was becoming a full-fledged mechanic with good experience in tool- and machine-drafting, machine-building and toolmaking.



Young Charles walking over the mountains to school in Békás Megyer.

My drawing board and T-square under my arm, I could be seen every Sunday, morning and afternoon, and three nights a week, tramping three miles over the hills between home and vocational school. I had to pass a cemetery on my way, and I admit that at night I was rather uneasy. Often when the wind was blowing a wired wreath would come loose from a cross and roll down the hill after me. I would be scared stiff and run like the dickens to get away. When I told Father, he would laugh and say, "The residents of a cemetery are well behaved: harmless, peaceful and noiseless. When passing a cemetery, take off your hat in reverence to those who rest there quietly; but look out for some of those who are not yet in there."

My father was the last man on earth to whom one could complain about fear in the dark. When we were small, he would send us out one by one at night to walk a mile in the dark on the 150-acre plant for matches that he did not need, simply to drive fear out of us. My mother used to cry and protest, and to please her he would follow us, making sure that we got home safely. We had no idea he was behind

us, and the system was effective—but it backfired on Dad. I was then about nine years of age, and not infrequently we kids under my direction would sneak out of the house at night to watch the workers' dances or parties in the plant—something we would not have considered prior to our "match" trips. Having conquered our fear of the dark, Dad had a job on his hands looking for us and telling us, "Come home, it is bedtime." Dad was better off during our period of fear; but he showed us not to be afraid in the dark.

Ever since I can remember, I was interested in mechanical things and inventing. At fifteen I had a very complete home workshop, which was located in our woodshed in the summertime and in my mother's kitchen during the winter. (My mother was always delighted when spring arrived so that she could have her kitchen to herself.) With a friend I conducted a sort of "toy contracting," business. These early inventions were not, of course, patentable, but I derived an enormous amount of satisfaction from them. I believe that the training stood me in good stead in later life.

As a fifteen-year-old apprentice in the machine shop, I had Herr Grabler as my instructor. However, everyone in the factory called him *Lärmás ur* (Mr. Noisy); he was always yelling at us boys, convinced that knowledge sticks better in the mind of the learner when it is shouted. Herr Grabler was an expert in figuring gear ratios; the only trouble was that he wanted me to know as much in one month as he had learned in thirty-five years. His greatest pleasure was to shout, "*Du Ezel!*" (You donkey!). He carried on as if he were an actor, trying to impress the rest of the factory workers. Everyone heard my lessons, and if I made any mistakes the whole shop knew it. But of course Herr Grabler meant well and I gained much mechanical knowledge because of—or perhaps despite—his daily shouting.

Whenever Herr Grabler had a special idea I was ready to cooperate. At one time he thought he could shoot rabbits if he had someone to pull a boiled cabbage in a net over the snow. In winter the rabbits can find little to eat, so they would follow the trail of cabbage leaves and end up in front of the hunter. This was quite a hobby with Herr Grabler,

The youthful "toy contractor"
in his woodshed workshop.

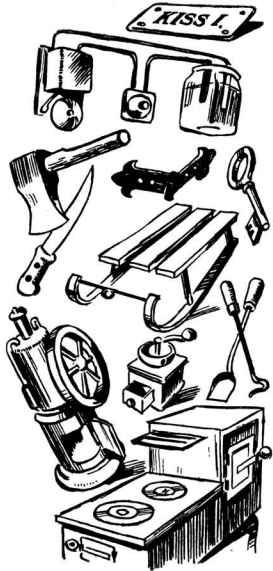

Left: Parts made in the Eisler workshop when young Charles was fifteen.
Right: A few of the items created in the Eisler woodshed repair shop.

"Du Ezel!"



and I had to do this four or five times during the winter months in order to please him. He was one of the instructors and his orders had to be obeyed.

He could not get a hunting license because in Hungary only the nobility or landowners had that privilege; so the underprivileged had to work out their own methods. If the game warden came along, only the boy dragging the boiled cabbage over the snow would be apprehended. If I was caught, I was prepared to say, "I am feeding the rabbits because they cannot find food in the snow-covered field." Meanwhile the big shot would disappear, leaving me holding the bag—of boiled cabbage. But I never got caught, and the big shot got quite a number of rabbits.



Outwitting the rabbits—and the game warden.

In Hungary it was against the law to disturb nightingales or catch them. However, Herr Grabler, my noisy instructor, liked to go out in the woods on a Sunday and listen to the nightingales sing, and catch them once in a while. He constructed a box with a trap inside, and I was asked to come along with him and set up the box. Of course he bragged about this to the other men in the engineering department. They advised me to take a couple of old tomatoes along, and when Herr Grabler wasn't looking to hide them in the box and close the lid. He would go around the trees, whistle at the nightingales to coax them and occasionally look to see if the box was still open. So when he looked and found the box closed, he quickly picked it up, hastened home and put it in a large cage. But when he opened it, no birds came out of the trap—only tomatoes where nightingales should have been. Of course he blamed everybody but me. Being my superior, he didn't think I would dare play such a trick on him.

When I was not attending classes I had an interesting job supplying electricity for the street lamps and for the homes on the plant premises. The lamps in both places received their electric power from a dynamo which was driven by a little twenty-horsepower engine. It was my job to keep up steam for this engine by firing the boiler. I had to watch the voltameter carefully to maintain a constant voltage. When people went to bed and turned off the lights, the voltage

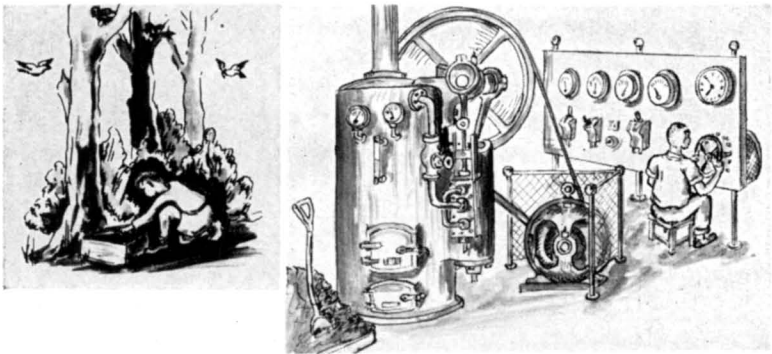

Young Charles, *left*, substituting tomatoes for nightingales, and, *right*, tending the boiler and switchboard.

would run up, and with a hand regulator I kept it steady at 115. At 10 P.M. all lights were out, and my evening's work was ended. In addition, I was the lamplighter and responsible for replacing burned-out carbons in the electric carbon lamps. I did this work for three years, one week on and one week off. There was plenty of time to read on the job, and it gave me a powerhouse background and experience in handling electrical equipment.



The young lamplighter on his rounds.

In the factory once or twice each week I attended to a large steam engine, and also fired three boilers. Mother didn't care for this phase of my work because I would come home so black and with such soiled clothes that no one recognized me. Also, she was afraid that something terrible would

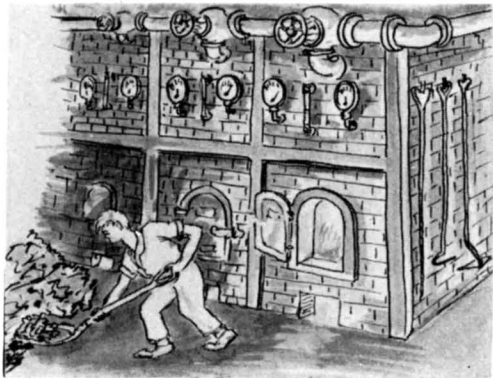

Firing steamboilers
at sixteen.

happen in the boiler room and she would never see me alive again. But I did this work in my spare time for three years with no mishap.

Finally I finished my mechanical and engineering studies; at the age of seventeen I was a licensed steam engineer and fireman of high-pressure boilers—one of the youngest in Hungary. The license meant knowing the maintenance and operation of steam boilers, steam pumps and steam engines, and the firing of high-pressure steam boilers. I was indeed fortunate in getting this diversified experience in which I acquired a vast store of general knowledge of plant operations. Of course, this was made possible largely through the fact that my father was an official at the plant.

The older workers got a big kick out of seeing this youngster starting a 200-horsepower steam engine and firing large boilers. Everyone called me *Fő Gépész ur*—Mr. Chief Engineer. Needless to say, I was very proud of the title.

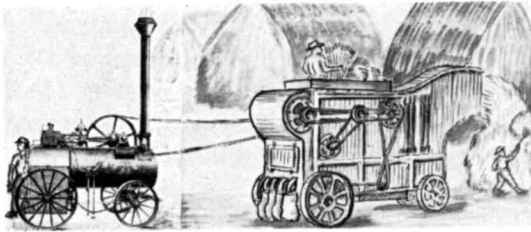

The youngest licensed locomotive engineer operating threshing machines.

In 1901 I decided to leave the factory and see what I could find for myself elsewhere. That summer I took a position for the harvesting as a locomobile operator, helping those farmers who had threshing machines. We would go from farm to farm offering the equipment on a rental basis, belting the locomobile to the flywheel of the farm's thresher. My job as engineer and fireman was to level the locomobile, belt it to the farmer's machine, brace all wheels and get up steam. Wheat-threshing started at daybreak and I had to have steam up at 5 A.M. It was a new experience, working with the Hungarian farmers from dawn to dark, eating goulash pre-

pared in the fields, and drinking wine from the *kulacs*. The pay was small, the hours long, and firing a boiler all day long was not child's play, but I liked the farm life. Of course, when the summer was over I had to look for something new.

Next I was hired by a small independent railroad company as a part-time fireman and engineer to operate a freight train on a short run. When I was interviewed by the chief engineer, he started right in by yelling, but he did not scare me for I was now well seasoned and thoroughly used to those big Hungarian "shouting bosses."

He yelled, "Are you the kid who thinks he can fire a boiler and run a locomotive off the tracks?" I told him that I fired four large stationary boilers and operated a large steam engine, and that his coffee grinder was not an eighth as big. I also told him I had my license. He called my former chief in the brick factory, who told him, "You can hook up all your coffee mills and that boy Károly will run them all any place you want." I got the job at once.

I had not thought I would ever meet anyone who could outshout Herr Grabler, but this new chief had him beat ten times over, consistently. This bullying attitude seemed to belong exclusively to Hungarian bosses; I did not find it in any other country in which I worked.

It was a junior-size locomotive, and I was to carry freight three or four times a day, about eighteen miles each way. I was not permitted to carry passengers. Often I would use the tracks which took me past the factory where Father worked and which I had left not long ago. The workers would line the tracks just to see Károly running the train, and Mother would always come out of the house when she heard my whistle blowing. My job was to get the train on the tracks at 4:30 A.M., start the steam and prepare for the regular run. After four months of this, although it was good experience and I considered it fun, I quit because of the early—and also late—hours. Getting up at 4 A.M. was tough for a fellow who liked to sleep, and Father convinced me that I could find something with more suitable hours.

Early in 1902 I obtained a position which was to be my last in Hungary. This time I worked in a textile factory,



Mother Eisler waving to her favorite engineer.

where my knowledge of German as well as my drafting experience were the deciding factors in hiring me. During the day I was a draftsman for a German engineer in the plant, making drawings to his instructions. And at night I was a volunteer fireman. This enabled me to help my folks a bit and have some spending money.

Actually, wages for the average worker in Budapest were so small that it was almost impossible to live decently. For example, although Father had a good position and we had a nice home, he never earned enough for all of us. His salary couldn't supply all the shoes and winter clothing we needed.

Very fortunately for us, we had relatives who supplied us with everything that Father could not afford. Although I resented it, from the time I was ten I remember going to my aunt or uncle or grandmother for the things we needed. No begging—we just said, "Hello, we are here again." This went on for seventeen years.

Without outside help, supporting a family merely by working ten hours a day was extremely difficult if not impossible. All my brothers were mechanics and none could get along with just a "regular" job—so I speak from experience. My brother Leo, in addition to his ten-hour-a-day machinist's job, worked three to five hours every night repairing odds and ends and thirteen to fifteen hours every Sunday, so that his family could eat a piece of meat once a week. So, even as a youth, I tried to make ends meet by holding these two jobs

The German engineer would lend me his engineering book

to read in the evenings, and I diligently did the problems he would give me. He liked my work and encouraged me. He even suggested that I ask the boss for a little raise, since he considered my work clever for a young fellow. But when finally I got up enough courage to ask the boss, he was furious and gave me a severe bawling out.

I decided then and there to leave Hungary. I felt it was no place for a progressive-minded, up-and-coming young fellow. The engineer told me that with my experience I could earn much more in Germany. I went home that night and told my folks that I was going to quit my job and try my luck in Germany.

Needless to say, they did not like the idea of a boy not yet eighteen leaving home. Mother started to cry. When Father saw that I really meant it, he told me, "If you have already made up your mind I will not stand in your way. Try it a while and if it does not work out the way you think it should, come back and we will greet you with open arms."

What I did not mention, even to my parents, was that it was my wish never to return to Hungary. I felt my country did not deserve honest, hardworking people; workers there were simply not being paid a living wage. My burning idea was to work in Germany long enough to earn my passage to the United States.

The day before I was to leave, a dinner in my honor was given by the friends who had also bought the tickets for me. My trip was to be via steamer on the Danube to Vienna and by train to Germany and Berlin. The steamer was to leave about 4:30 in the afternoon on a Sunday early in September of 1902. All of the family and my friends were there to see me off. It was the saddest day of my life. They played the old Edison victrola, a harmonica and a violin; they sang for me; and presented me with little cakes, cookies, fried meats, and even neckties.

Finally the time came—the deck was cleared. Everybody cried. Some of my friends shouted that I could still change my mind. I could not speak—all that I wanted to say to everyone stuck in my throat and I could not utter a sound. The steamer finally gave three long blasts and I was on my way—the first

leg of a voyage to find my fortune, and to learn more than I could in Budapest.



The steamer on the Danube. Destination: U.S.A.

Father had told me before I left that I would have to go far to find more beautiful cities than Budapest, and I had replied that I was not looking for better cities, only for better working conditions, where people are willing to give a boy an opportunity to earn enough to live on and still be able to help the family he has left behind.

Summer nights are very pleasant on the Danube. Sitting up all that night on a deck bench (sleeping accommodations were only for the rich), I wondered what the future had in store for me. Before my eyes were all the tears I had seen when I left Budapest and to this memory I added my own. I kept asking myself if this was necessary—to bring such sadness to my family and friends—but I had made my decision, and the boat moved steadily up the Danube.

3. ON MY OWN

WITH MY TRIP three-quarters completed, I realized that with the little money I had it would be necessary to stop off before I got to Germany in order to earn a few *kronen* to see me to Berlin with something in my pocket. In Grotau, a small town in Czechoslovakia close to the German border, I saw several tall smokestacks, and I said to myself, "Wherever there is a smokestack there is room for me." Whereupon I made my way to the factory which manufactured agricultural machinery and repaired locomobiles. I was interviewed by the factory manager and got myself a job testing locomobiles. This involved setting steam valves under pressure. During my three weeks there, I found conditions better than in Hungary. The foreman, for one, was much more dignified and considerate than the loud bosses I had known at home. I admired the Czechs very much for their human, dignified way of talking to their workers. I also experienced the extreme kindness of the Czechs to foreigners and to young people.

Of course, this was only a temporary stop. When I had earned enough for railroad fare and incidentals, I left for Berlin. In that large city I was in for a rude awakening. There were no openings for mechanics, draftsmen or even laborers. After a few days of futile searching I was getting desperate. Then by chance I happened to see in a trade paper that a factory in Eberswalde—about fifty miles out of Berlin—was looking for all kinds of help, including operators for steam cranes. I had just about enough money in my pocket to get me to Eberswalde and I proceeded at once, arriving in the evening. I had no place to stay, but it was warm enough to sleep out for the one night. Early the next morning I was at the plant—a very large factory on the Oder River. Once again I went before the chief engineer and once again, after he checked

my experience, I was hired immediately. I was assigned to the machine development department, where each worker made his own machine parts and drawings.

1 1

Eberswalde was a good-sized town of about 45,000. I liked working in Germany. There was better food, higher pay and a more friendly and understanding atmosphere in the factory, including the supervisors' attitude.

The workers in the German plant also had a better understanding with one another than had the Hungarians. I was invited to many homes and shown much kindness. They were very courteous and hospitable and tried to help in every possible way. The Germans are very strict in the factory, but not like the Hungarians. A Hungarian foreman is only happy when he can make you unhappy, but the German wants you to be happy when you work. The Hungarian likes to be tough when he is a superior. The German shows intelligence and kindness to the worker. With a few kind words and a friendly tap on the shoulder the smart foreman can double his production and cut his costs by better than half.

Leistungskarte-Formular A.	
Versicherungsanstalt: <small>(Dieses Feld hat keinen Geltungswert bei einem Unfall, sondern nur für die Versicherungsgesellschaft.)</small> Name: Brandenburg. Straße: Dolz. Dorf, Eberswalde.	
Ausgabestelle: <small>(Name der Leistungskarten A Nr. 1-35)</small> Ausgestellt am: 14. Juni 1903 <small>(Streuendauer*) für die Zeit bis zum 14. Juni 1904</small> <small>Zur Vermeidung der Ungültigkeit innerhalb zweier Jahre nach dem Ausstellungsdatum zum Umtausch oder zur Verlängerung vorzulegen.</small>	
Quittungskarte Nr. 1 für:	
<small>(Name und Adresse, bei Quittung und Gehaltskarte)</small> bei Ausstellung (Wohnort) Eberswalde dieser Karte (Berufstellung) Poliermeister geboren am 10. Juni 1884 im Jahre 1884 in Ungarn	
35 Eisler	36 Ungarn

Sick-benefit and police card issued to young Eisler by German police in Eberswalde, 1903.

On my very first day a man approached me and asked, "Say, young stranger, where are you eating today?" When I told him the factory canteen, he insisted that I go home to eat with him. His name was Carl Reichenberg. For the entire

first week I went to his home every day for lunch. I got to know his two sons, two daughters and his wife. She would serve me homemade bread and beer. The bread was delicious, especially with butter and cheese; but I could not cultivate a taste for the warm, sweet beer, and when no one was looking it went down the drain. After that week I saw the family occasionally on Sundays, when we would all go walking in the woods with picnic baskets full of hearty sandwiches. Mrs. Reichenberg was always very kind to me and whenever I saw her I would kiss her hands. This was a popular custom in Hungary, but it was unfamiliar to the German working class and her kids would get a kick out of my custom, especially since she would try to avoid the ceremony by hiding her hands under her apron.

The factory manufactured cast-iron pipe and machinery of all kinds. In addition to my regular job, I operated a crane evenings and almost every Sunday, loading barges near the



Operating a traveling crane on the river Oder. Eisler was responsible for firing his own boiler.

factory. Also, when the regular operator was off I would spend regular working hours at the crane. Handling these extra jobs won me quite a reputation for versatility. Today this diversity of work is virtually impossible, simply because organized labor prevents it. Nowadays a young man finds it almost impossible to acquire the experience that was obtainable years ago when there were no unions and your job was what you made it.

After about five months, I became restless once again, since I saw no real future in the job. I liked the work and even attended factory classes in drafting and engineering,

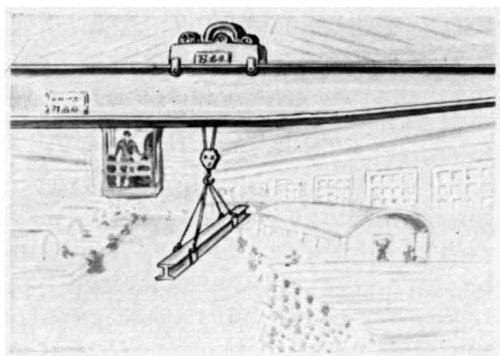

Operating a 10-ton traveling crane in an Eberswalde foundry in 1903.

but I wanted something better, and I left. In the same trade paper I had read once before in Berlin I saw an advertisement for young toolmakers. The ad mentioned that those who qualified would be given an opportunity to learn engineering, drafting and shop management, and would be chosen later for responsible positions in a fast-growing plant. The offer was placed by the AEG in Berlin, the German equivalent of General Electric, and I hopefully applied for the job in a carefully written letter.

When I was called for an interview, not only was I accepted by the company but I was placed in a rather select group of toolmakers who already had drafting and machine-shop experience. This was such a "special" toolroom group that some of the men were convinced that I must have had a rich uncle who had large investments in AEG or similar influence. Once again I reminded myself that my goal was the United States, but I could not turn down this opportunity for valuable experience with such a large company.

Probably I would not have landed that job if they had known that my time there was to be limited. As usual, I attended the factory-given courses, this time on toolmaking and tool design. And I came into contact with the social activities of Berlin. Once a week—on Sunday—I would get together with several boys from the factory school and go to a beer garden, where we sang, ate and drank a little. I had finally resigned myself to drinking beer and managed a glassful now and then. It turned out that one of the boys, Hugo,

had gone to night school in Budapest with me, and we renewed our friendship. He too had decided to go to the United States, and we made plans together. A steamship ticket from Hamburg to Holland cost \$25. From there you could get boat passage to New York for \$25, which seemed mighty reasonable. And so after six months with the AEG I could wait no longer, and we left for Hamburg as soon as we were financially able to take that step. Two days later we stood on the pier at Rotterdam and climbed the gangplank of the old steamer *Potsdam* which was to take us to New York. We found there was a fourth-class rate available for \$16, and we took it gratefully. As steerage class we were all herded in the hold of the ship like cattle, but that is what we bargained for. If they had sold fifth-class tickets I am sure we would have purchased them instead.

With little fanfare we were shortly on our way across the Atlantic. I had not returned to my family before leaving, and on deck I remembered once more the tearful parting in Budapest when I had last seen them. I thought of my sister and seven brothers, and of my parents; they had often expressed a wish to someday join me in the United States. I could not know then that, as the years progressed, I would not be able to accumulate enough money to send for them. In the beginning every cent I could save I sent to Hungary to help them out week by week. Years later, when I could afford it, they had grown old, and I felt it was better for them to live out their lives in the old country. I felt that America was only for young immigrants.

I did much thinking about my sister and brothers during the uneventful two weeks it took to cross the ocean. I have not spoken much of them up to now, and they will not play much of a part in my story after I reach the United States. At this point, therefore, I would like to summarize the lives of each of them, taking leave, for the moment, of Károly, the tossing steamer and the year 1904.

/ /

The eldest child George came to the United States about fifty years ago, having studied in Zurich, Switzerland, and



Left: (above) My mother at 24, Budapest, 1885; (below) My parents, Adolf and Helen, married in Budapest, 1880. Center: (above) Rudi, Budapest, 1940; (below) George, 1940. Right: (above) Emil at 26; (below) Franz at 20.

spent some years in London. In Hungary we called him *könyves kálmán* (the bookworm). He was for several years secretary to Judge Ben Lindsey, the famous child psychologist in Denver. At one time he was in charge of the Americanization Department for the federal government in Youngstown, Ohio. He was also secretary to Buffalo Bill Cody for many years, traveling with him all over the world, including darkest Africa. During the First World War he was in the letter-censoring department in Washington, D.C. About forty years ago he published a small newspaper in Chicago. In his younger days he was an amateur actor and soapbox orator. For the past twenty-five years he has operated a travel agency in Newark, New Jersey. Now a widower, he has always kept himself rather aloof from the rest of the family. Even though he lives less than five miles from me, I have seen him only

once in the past fifteen years; in the fifty years he has been in this country I have talked to him only eight times. His hobby—reading—seems to be his only interest at present.

Emil was the third son (I was the second). He settled in Yugoslavia, where he was put in charge of a large lumber concern owned by his brother-in-law. He served in the Hungarian artillery in both World Wars. He was married twice and had five children. When the Nazis took over in his city, in 1942, they ordered him and his wife out into the street and shot them down in front of their home. Shortly thereafter, his beautiful twenty-two-year-old daughter committed suicide.

Emil was in the heavy artillery in the Hungarian Army in World War I for four years and during World War II for about three years; his military service lasted eight years in all. His family lived in Zareb, Yugoslavia, this city where Crown Prince Franz Ferdinand, the nephew of the late Kaiser Franz Joseph of Austria and Hungary, and his wife were killed by a Serbian nationalist in 1914. A bomb was thrown into their carriage. One week later World War I had erupted. The bombing was made to order for the "kaisers," all of whom were seeking an excuse to start a new war.

Emil had two other fine daughters who luckily had married Greek Catholic boys from the neighborhood. When the Hungarian and Serbian Nazis started to kill non-Christians, the girls were baptized as Greek Catholics, hiding in the church for protection. This story was told to me by the older

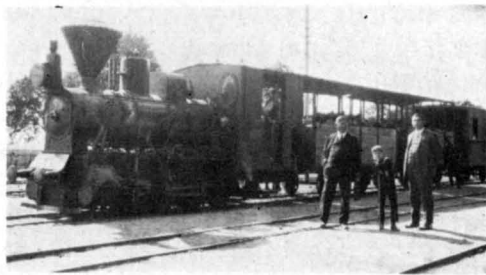

I entrain for Yugoslavia in 1936 to visit my brother Emil, whose company provided a special narrow-gauge train for the occasion.

daughter (who has since passed away): their husbands, learning through the grapevine that the Nazi killers would storm the church in a day or two, informed the priest, who double-locked the giant door of the little church, standing guard before it with a large crucifix in his hands. The mob arrived, demanding the surrender of the girls.

The priest replied, waving the cross before their eyes, "Do not dare break these doors open! This is God's house and any people in this church, hiding or not, are my people!" The hoodlums dispersed, and the girls lived to tell the story. One girl still lives in Belgrade with her family.

It is appalling that such things can happen in a civilized world. What have we to look forward to, what sort of future can we offer our children? When I was in Hungary after the massacres, I was told the Hungarians killed more Jews proportionately than had the Germans. They wanted to show they could outdo the Germans. No mercy was shown, especially in the country. Jews and Gentiles alike were slaughtered. A Jewish name or Jewish features were sufficient to insure death at the hands of the Hungarians. When I was in Budapest in 1948, I looked up everybody I could and helped wherever possible. I ran an advertisement in a newspaper: "Eisler is here from America, wants to meet friends and relatives in Cofee Brody O-Buda at 7:30, with dinner and gypsy music, to get acquainted before going back to America." Among the many who came, thirty-eight in all, was an old school friend, Joseph Roth, then sixty-five. He had no teeth, could not see because he had no eyeglasses; his clothing bespoke the terrible poverty he had endured. He was the only living school friend who had contributed a part of my steamship fare in 1903 when I left Budapest for Vienna. When he saw me, he started to cry. I had not seen him for forty-five years. Because his name was Roth, he was thrown into jail several times; they wanted him to admit he was a Jew, when actually he was an ardent Catholic. He was placed on a train for Auschwitz, because he could not prove he was not a Jew. A typesetter by trade, in his younger days he belonged to no church, but I was very often with

him in the Catholic church as a boy. After years of hardship, proof that he was baptized as a Catholic was discovered in the church records by Father Sagmueller. This did not solve matters; the name Roth was Jewish in the eyes of Hungarian heroes.

Among my guests was an Eisler girl, whose husband, a Catholic boy, was a streetcar starter. He told me the hoodlums looked for his wife everywhere and that he outwitted them by having her bricked in a double wall in his cellar for two and a half years. He kept her hidden there, seeing to it that she got a little fresh air and food only at night. I was proud to call him my relative.

He told me stories that defy description, stories of human bestiality almost beyond belief. I asked him, "Would they have killed you too?" He assured me that their aim was to exterminate every Jew in the world. He is alive today only because the American Army put an end to the massacre.

And when I talked to Germans in Germany, they told me it is all propaganda, not a word true, that they had lost the war because they were too humane. I hesitate to think what their behavior will be like in any future conflict!

One of Emil's two sons was killed in a German concentration camp at the age of eighteen. The other was in Auschwitz for three years; his job was to extract the teeth from the gassed dead and throw the bodies on the chain belt feeding the incinerator. He told me that 60 to 75 bodies were converted into ashes every day. We still live among barbarians when stories like these can occur in a "civilized" day. One wonders what kind of world our children can look forward to.

The fourth son was Mike; the only picture I have of him is the photograph reproduced here; he is on the far right. Mike was a machinist. Inventive in the mechanical field, he was unable to land a job in his native Budapest but he was quite successful out of town. He roamed around a lot, however, and always expressed the desire to go to America. I am sure that if he could have done so, being very ambitious, he would have made good here. But fate would not have it this way. In 1904, the very year I decided to leave for America, Mike was critically injured in a factory accident.

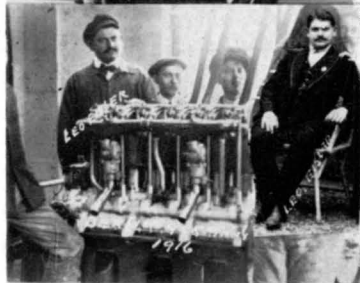
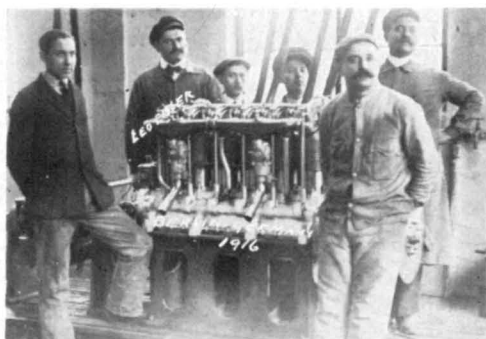

Above: Mike (far right) and Leo (second from left), Berlin, 1916. *Right:* (above) Adolf Eisler at the grave of his wife, Budapest, 1933; (below) Leo standing before airplane engine; (insert) Leo.

Ten days later he died in a Budapest hospital at the age of twenty.

Leopold, the fifth son, was an expert on motors, working in Germany as well as in Hungary, specializing in airplane engines. During the Second World War he worked in a German military airport. Despite his value to them, he was shot by the Nazis, together with his wife. A daughter, twenty-five, committed suicide. His son Gyuri, his then only living child, was a prisoner of war in Russia for six years. He was twenty-two at the time, and, like his father, an expert on motors. The Russians made use of his ability, giving him a responsible position in their motor transport service. For one period of his "term," Gyuri was a truck driver taking German POWs to a mountain hideout, where they were executed en masse by Russian firing squads. When he was released in 1948, he went back to Hungary, looking for his father, mother and sister. He had not heard about their end, and it was a tragically unhappy chore for the neighbors there to break the news to him.

He walked into the house where his father had lived for

many years, and everyone cried with him when they told him about his folks. He had no place to go; he did not know anyone. So many changes and killings had occurred since he had left home six years before. An old neighbor and friend, Kiss Bacsí, told him, "Son, you have no one here, so why don't you stay with me?" He accepted the invitation and three months later married the daughter of his benefactor. I happened to be in Budapest at that time, in 1948, and I arranged the wedding and was best man. At least I could make a nice wedding for the only son left by my brother Leopold.

The sixth son was Rudi, who spent thirteen years of his life as a soldier—seven years during the First World War and six in the Second. He was the most decorated soldier in his regiment. But in spite of this and the fact that he was wounded in action several times, the Nazis called him out of his house, ripped his medals from his coat and shot him down. His wife and daughter (his only child, a dental technician), who had witnessed his murder, buried him and then took their own lives. Too many of the Eislers met their end in the same manner.

Between wars I set him up in a store to sell ready-mixed paints in tin cans. Among his handicaps was the inability to collect money from poor people. He trusted everybody; and the business was short-lived. I then arranged a monthly drawing account for him in a Hungarian bank.

My brother Franz Eisler was the seventh son. He studied banking and was a bank department head for twenty-five years in Budapest. He visited the United States three times but would not consider staying here because he had such a good position in Budapest and could look forward to a valuable pension. As an officer in the Hungarian Army in the First World War, he was taken prisoner by the Russians and spent six years in Siberia. When he returned, Franz joined the Hungarian Officers Guard and felt secure in the assured protection of his high-ranking friends. Nevertheless, he was killed by the Nazis, together with his twenty-year-old son. His wife escaped by disguising herself as a peasant field-worker. Ironically, it was a "friend" who betrayed him to



Left: Franz, a lieutenant in the Hungarian Army, a prisoner of war in Vladivostok, 1915. Right: My youngest brother, Lajos.

the Nazis so that he could gain Franz's position.

Emma was the only girl in the family. She married a boy of Polish ancestry and had two daughters, one of whom told me the following story: "When the Nazis came to Budapest, they shot Daddy and chained and dragged Mother and both of us with other women and children over the Austrian mountains in the middle of winter. The roads were covered with six inches of snow; Mother could walk no longer without food, water and warm clothing. She told us these were her last moments. The Germans unchained her and us, and she died there on the road. We girls, eleven and thirteen, buried her on the mountainside. Lost, without anyone to look after us, we roamed aimlessly for two years, going from farm to farm until the war ended. Then the authorities placed us in a camp with many others who had lost their parents."

It is unbelievable that two young girls were able to stay alive under such conditions: roaming in winter through strange mountains, sleeping in stables and barns, without food. When they were found, they both were in rags and half-starved. Eventually, they both married and settled in Budapest.

When I visited the girls in 1948 they told me the story of their mother's tragic death. Emma had begged them not



Top: The Eisler family, Budapest, 1897. *Left to right:* Leo, Emil, Mother, George, Rudi, Charles (known then as Károly), Father, Miska; Feri is seated to left of Father. *Insert:* Emma (our only sister) and Lajos. *Bottom:* (left) Charles as a volunteer fireman, Budapest, 1915; (center) Emma, at 15, Budapest, 1915; (right) Adolf Eisler at 36, Budapest, 1885.

to tell me how she had died. I loved her dearly—the only sister of eight brothers. From the time she was four until the Nazis took her, she had everything any girl could ask for—I would send her shoes, clothing and food from the United States. When she was seventeen, I opened a charge account for her in the local drugstore so she could get everything a young woman needs: perfumes, toiletries, cosmetics, etc. Always well-dressed, she matured into a beautiful woman. For what crime did this poor, innocent girl have to suffer so much from the barbarian Nazis? I hope that those beasts who caused her sufferings will never find peace of mind on earth or in the hereafter.

Lajos was the youngest of the nine Eisler children; he was about twenty-five years younger than George, the eldest. He learned the tool-making trade in Budapest and obtained a position in Coburg, Germany, where he furthered his educa-

tion. He came to the United States about thirty years ago and since then he has been employed by my company as a machine-builder. He is married but has no children. Like me, he enjoys country life and has a small home on my farm and spends every weekend there, rain or shine.

4. A NEW LAND

ON NOVEMBER 14, 1904, after thirteen days of rough sailing, the *Potsdam* arrived in New York City. When the steamer passed the Statue of Liberty, with all the horns blowing full blast, a chill ran through my body and a crying spell gripped me. Many others also knelt, cried, and prayed. I said to myself, this is my future here—here I will live forever—here I shall find happiness and maybe my fortune. I was twenty; it occurred to me as I gazed at the Lady with my eyes tear-filled that she, too, was twenty. She seemed to stand for eternal youth, for everything that the immigrant has missed in his fatherland and longs to find here in this new country. Of course, the fourth-class rate of fifty-five years ago was not quite as good as the shipping facilities for livestock today, but there were no complaints; on the contrary, coming to the United States was everybody's dream, and those who made it gladly overlooked the physical inconveniences.

I had on my back only a small knapsack and \$1.96, but I felt like a prince. I could not believe my eyes when I saw that the cheapest saloon gave away more food for nothing than I could have purchased for a week's wages in Hungary, working twelve hours a day. The food that is wasted in this country by one family then and now would be enough to feed a Hungarian worker. It seemed almost impossible for anyone to go hungry here.

Of course, it took a good number of years, from job to job, before I finally got to a point where I can say my efforts actually paid off and the money began to roll in; that came around 1920, when I started my own engineering company. After that occurred, I found steady progress to wealth. I worked for twenty-five years, sixteen hours a day, often on Sundays and holidays. I always remembered a saying of my

father: "Hammer the iron while it is hot." I attribute my success to hard work and the fact that I produced something for which I found a market, and kept hammering away at it day and night without a stop. I can truly say that everything I now possess I worked for.



The steamer landed about noon. My friend Hugo Rosner, with whom I made the trip, had lost all his money playing poker on the boat, and he now had even less than I—about \$1.25. We would have to be very careful with this money, for we were in a strange land, without relatives or a job.

At Ellis Island our eyes and hands were examined.

"Move your fingers," directed the inspector. "What can you boys do?"

We said we were toolmakers and machinists, and he replied, "Good, go ahead. Lots of luck to you boys."

We were told on the Island that we could not stay in New York City and that we would have to buy a train ticket for somewhere out of town. Hugo knew one person in this country—a chicken farmer, a friend of his father, who lived in New Jersey. We bought two tickets at thirty-five cents each for Bound Brook, New Jersey, where this fellow Meyers had his farm. We arrived at night, having walked several miles from the railroad station. Bound Brook was then real "country," consisting of farms exclusively. Since it was pitch-dark and Hugo did not want to disturb the farmer's family so late, we walked until we found a spot in the woods where we could spend the night under a large tree. We soon fell asleep. When we awoke early the next morning we were surprised to find that there had been a little shower during the night, and we both looked a mess. In fact, we needed a wash-room and clean clothes so badly that we had a good cry before we started to the farm. I had left at least a livelihood in the old country and Hugo's father was a wealthy machine manufacturer in Budapest, where young Hugo had everything he ever wanted, yet here we both were in the United States, sleeping under a tree in the woods, with no money, no home and nothing to look forward to.



The first night on American soil afforded rude sleeping accommodations.

We arrived at about seven o'clock in the morning and farmer Meyers was already at work. He recognized Hugo, and he had a good laugh as he looked us over and heard of our experience in the rain. His next words warmed our hearts: "Did you boys have any breakfast?"

We said, "Not today."

He quickly yelled to his wife, "Mamma, make the two greenhorns a good breakfast."

When the pork chops, fried potatoes, bread, butter and coffee were put away, we got down to business. Farmer Meyers was a little short of help; he said that if we wanted to help out, we could stay for a while. He asked me my name and then, "Well, Charlie, what can you do?" When I told him that I was a machinist and could build him a new chicken coop, he was delighted. Also, his farm machines were in very bad shape and needed repair. He said, "I don't expect you boys to work for nothing. I'll pay you five dollars a week, good eats and a nice clean room for the two of you."

I answered, "Good, I'll repair everything that needs repair." I almost bit off more than I could chew; it seems there was no end to all the work there was piled up for me. We worked from 6 A.M. to 8 P.M. the first four days of the week, and on Fridays the three of us killed and cleaned the chickens and ducks for the market on Saturdays. The market interlude gave me time to look around for possibilities and make plans.

I wrote to a friend of mine, Sandor, whose father was a foreman at the Westinghouse plant in East Pittsburgh. A few days later I got an answer from him stating that he thought

I had a good chance there despite the fact that 1200 men were being turned away at the gate every day, and if I didn't get anything right away I could live with him until I did. With this encouraging note, I told Mr. Meyers I was leaving. He was of the practical opinion that it was almost impossible to find work anywhere at this time, and suggested I would do better to remain with him. He would pay me eight dollars a week. However, Sandor had indicated that it was mostly unskilled laborers who were out of work, and I explained to the farmer that I had learned a trade and must seek work in this profession. I thanked him and his wife for the fine home and food they had given me, and I set off for East Pittsburgh. I had stayed with them for three weeks and I had made fifteen dollars.

The first thing I did was to buy a pair of good shoes for \$2.25, because mine were spoiled from the farm work. Train fare was \$8.50, which left me a few dollars for meals and incidentals. I took the night train; it did not break any speed records, and I spent the next nine hours riding west.

When the train pulled into East Pittsburgh there were about eight boys and girls from Budapest waiting for me; we spent the next hour recounting experiences. Then I was taken to Sandor's house, where his mother gave me breakfast. A room had been prepared for me. After some more visiting, I got my first instructions on how to look for work. I would have to purchase a thirty-dollar tool kit, which I could pay out at a dollar a week. I was told that it would not be necessary to learn English since all foremen were either Hungarian or German and I spoke both languages.

Early the next morning I went to the Westinghouse employment office. I saw about nine hundred people waiting to be called and I said to myself, "What are my chances here with so many people standing in line looking for work? I'm still a greenhorn and the old-timers will come first, *if* there is any work." Suddenly the employment man opened the office door and yelled out, "Are there any toolmakers here?" I raised my hand; my heart was pounding so I could not talk. When I was called into the office I was so excited that what little English I had learned was forgotten. He ques-

tioned me in German, asking what I did in Hungary, if I had any toolmaking experience and if I could make working drawings, etc. I was given an examination, which I passed, and then I was told to report the next day for work at 7 A.M.

Of course I was overjoyed, and I learned that although regular hours ended at 6 P.M., I could work until 9:30 and also on Sunday, if I wished. This was music to my ears. For a start, I made about \$42 every two weeks, being paid in gold pieces. I still have in my possession the first gold coins—\$2.50, \$5 and \$10 pieces—paid to me as wages in 1904 at the East Pittsburgh Westinghouse plant.

In a short time I become a tool draftsman, detailing and drawing the tools that I had previously been making. I was obliged to join the International Association of Machinists; this was compulsory. In 1904 there was no overtime pay, paid holidays, vacations or hospitalization. We worked ten to twelve hours a day and often on Sundays. Apparently all the factory workers came from Europe; I saw no Americans in the plant. German, Hungarian, Polish were the languages spoken, with little or no English. We all got along well together, since everyone was happy to be working at all. There were great numbers of men out of work at the time. Laborers received six dollars a week for a 10-hour day, six days a week; houseworkers ten dollars a month with board; farm helpers five to seven dollars a month—and still jobs were scarce.

Of course, the skilled toolmaker was at a premium. Just the word toolmaker or tool draftsman got you a job in almost any factory in the country with no difficulty. It was the beginning of the tooling age, so to speak.

A knowledge of English was unimportant, since all the toolmakers were foreigners or sons of foreigners—Germans, Hungarians, Poles, etc. In fact, if you did speak some English in the factory, your fellow greenhorns would be quick to spot you: "Hey, big shot, no more can speak Hungarian? What's the matter, ashamed to talk your mother tongue?"

The Europeans dominated the field of good mechanics because of the European apprentice system, in which every boy participated from an early age and thus received a very thorough training.

This little anecdote can be appreciated best if the reader remembers that Europeans here in 1905 all continued to wear the costumes of their native country, and thus their nationality could easily be identified. Hungarians were called *hanyak* or *goulash* by the neighborhood kids; Italians were called *wops* or *dagos*; Swedes, *woodenheads* or *waterheads*; Poles, *polacks*; the Dutch, *wooden shoes*; the German, *sauerkraut* or *Dutchman* or *Kaiser*; the Englishman, *John Bull*, etc. The hangers-on in the street would yell these names whenever they recognized a foreigner. Foreigners in general were all called *greenhorns*.

I think that radio, and even more television, has had much to do with making kids today better acquainted with peoples of the world, with the music, art and science that immigrants have brought to the United States from all parts of the world. Boys and girls today realize that our knowledge comes from every part of the globe, and they show more respect to the immigrant. People from everywhere have helped to make this the greatest and most liberal country in the world.

Well now, an old friend had come to Pittsburgh to visit me. As he walked down the street with the typical canary feather in his hat, high-button shoes with elastics up the sides, a little handbag, etc., the kids followed him, yelling, "Greenie, greenhorn, goulash," and what have you. They tried to take his feather, buttons and handbag. The poor fellow started to run and then they chased him in earnest. By the time he got to my house about thirty kids—boys and girls—were running after him. He managed to get inside the house, though he was out of breath for fifteen minutes. He could not figure out what had happened. I tried to explain to him that this was the American children's way of welcoming European immigrants. It was difficult for him to understand.

This brings to mind a more recent anecdote: A German, fleeing from the Nazis, sighed happily when he saw the Statue of Liberty from the boat. Next day in New York he went to a fruit shop.

"Give me a dozen oranges."

"For juice?" asked the sullen clerk.

Without answering, the refugee walked out—deeply disappointed.

I had a memorable experience with the family I boarded with. Most landladies spoke no English, and mine was no exception. Actually they did not need to know any English because the butcher, the grocer and the baker did not know the language either. Generally, the European people patronized the European stores; occasionally when they got into an English-speaking store they were ashamed to stutter before the other customers. My landlady asked me to teach her English—at least enough to buy groceries, etc., in the American stores.

Her husband and I decided to play a practical joke on her—I taught her the wrong words, such as “meatichko” for meat, “breaditchko” for bread, “pickletchko” for pickles, etc. She wrote these words down carefully and off she went to the American store to read off her English to the butcher and grocer. Of course they realized right away that somebody was playing a trick on her. They burst out laughing. Embarrassed, she ran from the store. Furious at me, she threw dishes and chased me around the table with a carving knife. Luckily, her husband intervened and tried to smooth everything over, explaining that it was only done for laughs. But she cried and shouted, “I don’t want to see that good-for-nothing fellow any more! I never want to talk to him as long as I live!”

Her husband and I worked together and had several good laughs the next day over the incident, but she would never forgive me. She told her husband she would not cook for me any more. She was so mad I had to move out. Whenever I saw her after that she would not talk to me.

I had only been working eleven months at Westinghouse when a strike was called by the machinists union. It was early in the spring, and the strike closed the plant for seven or eight months. Naturally, I could not wait around, and I looked about for something else. Two weeks later I left for another town, and my friend and his wife a few years later went back to Hungary for the rest of their lives. I tried for many years

to locate them, but in vain. No one knew where they were; they had simply disappeared.

About thirty years later I went on a visit to Budapest, and I noticed an article in one of the Hungarian newspapers about Odon and his wife, that they had once lived in the United States, etc., and that he was elected mayor of Gödölö, not far from Budapest. I made a phone call to the mayor to find out whether that was really my old friend from America. It was.

I immediately invited both for dinner at the Hotel St. Gelert in Budapest. I greeted them after thirty years with flowers, wine on the table and a gypsy band. I kissed her hand. She kissed me on the cheek and then grabbed me around the neck and cried. When she could speak she said, "My dearest Charlie, I regret forever that our young friendship ended on account of that little fun we all had over your English teaching." She told me that after I left she learned very little English and in thirty years forgot it all—but not the English I taught her. To my great surprise, she still had that little paper in her pocketbook, with my name and the date and the words over which she had gotten so mad that she could have killed me.

In 1948, when I was in Budapest the last time, I went to the mayor's town. I was told they had both perished in a bombing raid during the war. This was the end of a boarding-house friendship I shall never forget.



Boarders, quite popular fifty years ago, are now a thing of the past. A young bachelor today lives in small hotels and eats in restaurants or does light housekeeping. Not many housewives today will tie themselves down with boarders. Years ago the landlady washed your clothes, cooked for you, sewed on buttons and mended your socks. When I was a boarder in East Pittsburgh in 1904, I paid \$3.50 a week for room, board, washing, mending, ironing and three meals a day, seven days a week. I also had my own bed. There were usually two young men in a room. A room without meals, in a private home, would cost \$1.25 a week for two. Quite

frequently a spare room for one could be had for only \$1 a week. Of course, life was much simpler then. I never heard in those days of any working men drinking juices or eating grapefruit and buttered toast for breakfast!

Here are a few of the food prices I can still remember: a dozen eggs, 12 cents; one pound of raw ham, 9 cents; a loaf of bread, 3 cents; one dozen rolls, 6 cents; steak, 21 cents a pound; a quart of milk, 5 cents. Soup meat and bones and liver were free in the butcher shop when you purchased pork chops for 11 cents a pound. Roasts were 15 cents a pound. The best shoes, Walkover, a popular brand which I always purchased, sold for \$3.25 a pair. A good suit of clothes cost \$12. A five-room home rented for \$12 a month; of course, there were no facilities of any kind except a coal stove in the kitchen. The heat from the kitchen stove was sufficient during the week; the parlor stove was used only on Sundays. A ton of coal cost \$6. Only outside, in the back, did they have running water. Life was very primitive; wages were low and so was the standard of living.

The greatest boon to the greenhorn was the free lunch in every bar and saloon. Men who would otherwise have gone often without eating had a good meal free for a nickel beer. The saloonkeepers were outdoing each other trying to give a better lunch with the largest glass of lager beer—all for a nickel. I remember those who worked in factories ten hours a day and walked to and from work to save 10 cents for two beers and free lunch. What I could never understand was how all those saloonkeepers got so rich, in spite of the beer being only 5 cents a glass and all that free eating. I knew several of them who became very wealthy in a few years.

I am very much afraid that one day the whole system of spiraling wages and high-pressuring the employers will backfire to the disadvantage of the workers. Everything we possess must be earned or worked for; otherwise we will unbalance our system, and many industries will face financial ruin. There is an old, true saying: One cannot expect something for nothing. There will come a point when, because of the great discrepancy in wages between European, American and Asiatic mechanics, there will be such a degree of underselling

from foreign manufacturers that many American companies will face crucial drops in sales. The ones who will suffer most are the small manufacturers who cannot overcome the financial handicaps imposed by the unions. The worst troublemaker is the "seniority law," the unreasonably rigid union rule that the manufacturer must pass up the possibly better mechanic for the worker who has been employed for more years. The union thus forces the employer to use the labors of the less valuable, less useful man; this is an obviously poor business practice.

In my opinion, strikes have never really accomplished anything of merit. They are hardships to worker and company alike; no one reaps any benefit from strife. The general prosperity of this country would have insured just about the same advantages for wage earners without union pressures. The many fringe benefits that must be paid by the small businessman to his employees are putting him on the verge of closing his doors in many cases. It is all right for GM or Westinghouse, with their huge organizations, to stand these pressures, but the smaller shops cannot keep up under these unrealistic burdens. It seems to me that keeping the small shop going is an important aspect of our economy; it is the small bosses who provide work for men the larger companies cannot or will not employ. Their success or failure rests with the union leaders, and unless labor-management difficulties are remedied soon, we will all face a troublesome future.

No matter how the government feels about it or how it dislikes the trusts, they are the only ones who will be able to operate before long. They have stricter discipline, more ways of getting better production through closer supervision. They are the only ones able to pay higher wages. The small manufacturer does not have an assembly line. In the relatively small machine shop most workers do as little as possible—just enough to get by. Workers in general are not as interested in their work as they were years ago.



Around 1904, amusement in the United States on Sundays consisted of going to the railroad station to watch the trains

go by and see who got on and who got off—in between reading the funny papers. To those sitting around the stations it did not make much difference whether they knew anyone or not. Seeing strangers come and go, from anywhere to any place, was interesting, and it passed the time on a Sunday afternoon. You often saw people, young and old, lost, crying and waiting for help—mostly those of foreign origin who could not speak English. They were either lost, had lost their belongings on the train, someone had taken their belongings or they had lost their baggage checks or return tickets; at any rate, something went wrong for someone every Sunday.

I shall never forget one Sunday—I saw a man sitting on a bench in the railroad station, crying like a little child, surrounded by fifteen or twenty people including a cop. Everybody wanted to help but no one could talk to the unfortunate man. They asked him, are you German, are you Polish, are you Serbian, Italian? He simply could not understand a word.

I looked on and finally said to the officer, "Let me try, maybe I can talk to this man."

Everybody yelled at me, "Get away, get away, you kid! If all of us can't talk to him, how do you think you can? You're not a wizard, get away!"

But the man wore big boots, a feather in his hat, a hand-embroidered soft shirt with fancy buttons. I recognized that he must be Slovak or Hungarian. He was a Hungarian, lost and without money to go on.

The cop took off his hard helmet and said, "Ladies and gents, here is a helpless immigrant. Let us show what America is. Let's help the poor fellow; let's all pitch in a few pennies."

In a few minutes he collected more than enough for the man's fare. We purchased a ticket to his destination and sent a telegram to his brother. The Hungarian was overcome; he cried again, and I conveyed his thanks to everybody in the crowd and the cop. Then we put him on the train and sent him off to make his home in the greatest land in the world.

5. MAKING PROGRESS

SOON AFTER this strike began, I went to work for an old German farmer, repairing his machines. The pay was only five dollars a month, and one month was all I stayed. What impressed me most about this family—the Chefkos—was the food. Never have I eaten so well (and so often) as on that job. Picture a breakfast of two pork chops, two lamb chops, pounds of steak, potatoes, etc. Our family of nine kids in Budapest did not see that much meat in a whole week.

But all immigrants were not as fortunate as I was. Many encountered severe difficulties. I know of one case of a Hungarian machinist who came to East Pittsburgh. He could not speak a word of English, but he went looking for sleeping quarters, though even the signs BOARDING HOUSE or BOARDERS WANTED along the streets were a blank to him. It was late one summer evening and he saw a lady leaning out of a first-floor window; he waved a dollar and called out, "Lady, give one dollar, give sleep." She promptly had him arrested. No one at police headquarters could understand him. The poor fellow stayed in jail for months. No one cared; he was of no importance—only another fresh immigrant. One day an itinerant salesman of prayer books, calendars, pencils, and other items usually purchased by immigrants happened to come through the jail peddling his wares. He also was a Hungarian, and when he asked the poor fellow why he was in jail the story came out that the lady construed his fanning a dollar bill at her as disorderly conduct. The merchant explained this to the authorities and the immigrant was released. Later the merchant, who was very popular with immigrants, set up a steamship-ticket and money-sending office for Hungarians, and finally became a banker. When he died fifty years later in New York, he left many millions of dollars. Known as Kiss

Banker, his best customer and advertiser after the jail incident was this poor immigrant who cried like a baby when, after nearly six months in jail, he heard his first Hungarian words from the peddler.

My next position was in Rochester, New York, where I worked as an instrument-maker for Bausch and Lomb. The work was very precise—making gunsights—and I received twenty-two cents per hour. The average laborer there received eight dollars a week for a ten-hour day. Mr. Lomb would walk through the plant every day. He had been an officer in the Civil War and had lost three fingers on one hand. When he met me, he asked in German what I had learned in Europe, and I told him. Then he said: "I want every boy to go to night school regardless of his former schooling or experience."

Mr. Lomb was the sponsor of the Rochester Technical School and I attended night classes there in engineering, mechanical drawing and English for two years. The school improved my English to such an extent that I gave lessons to other Hungarians. Also, I came to know many fine young people here that I would not have met otherwise. Though I worked for Bausch and Lomb for about eight months, I continued night school even after I left the company.

MECHANICS INSTITUTE

EASTMAN BUILDING

Admit *Charles Euler*
 to *Mech. Drawing 1st yr Eng* Class
 Course Ticket, \$ *5⁰⁰* Date *Sep. 2* 190*5*
 No. *53* JOHN A. STEWART,
 Financial Secretary.

My night-school card, Rochester, New York, 1905.

The only night that I permitted myself any relaxation was Saturday, when the young people would go dancing or on a buggy ride. I became especially friendly with Joe Krall, a boy with whom I worked. We would spend every Sunday on

picnics, taking our schoolwork, sandwiches and newspaper along on our bicycles. There were no movies, no radio or



Above: Eisler in 1909 in Freeport, Illinois, during his tenure with Hoefer Manufacturing Co. *Below:* Eisler, left, with his friend Joe Krall, Rochester, 1905.

television, and no automobiles, and so bicycle-riding was quite popular. In fact, most of the workers used this inexpensive and convenient form of transportation to and from work. The cost was small—nothing down and a dollar a week was all you needed to buy one.

Joe and I would often help out on the picnics, making sandwiches, preparing the cold cuts, and cooking the goulash. Our only pay was free eats and drinks. Also, we were both single, and when dancing partners were needed we two were always ready. Our friendship ended when Joe fell in love, eloped and settled in Montreal. Eventually he became a superintendent with the Westinghouse Co. in Canada; he died at the age of fifty-eight.

I boarded with an Austrian family named Schtundner. The son was also a mechanical engineer. At night, when I would be studying, Grandma Schtundner would watch me through

the crack of the door. She wasn't interested so much in what I was studying as in how much gas I was burning. (We had no electricity.) She finally told me I was burning too much gas and she would have to charge me twenty-five cents extra per week for the additional fuel that I was using at night.

I remember an interesting experience in Rochester in 1907, when I was boarding with a German family. There was a young couple in the house; they seemed very nice, very friendly. The wife played the piano and the husband the violin and very often we all had pleasant evenings together, and sometimes we attended concerts on Sunday. The man was a lithographer and the wife worked in a printing shop as a proofreader. They appeared to have a little more money to spend than the average couple those days but I did not think anything of it since they both worked and could afford to spend a little more on themselves than the average worker. She was only about twenty-three, well educated, and always dressed like a little princess. He was about twenty-five like me, and we three had lots of fun dancing once a week.

There were about twelve at the dinner table, all regular boarders. Then I noticed a stranger eating with us and sizing us up carefully. But I was not suspicious—I figured, simply another boarder eating at our table. He was introduced as Mr. Ferguson, a visitor from out of town—his firm was in Chicago—who would be here a few weeks doing some special advisory work in a local factory. We even became very friendly, and I began to consider him an additional competitor for the attentions of the attractive young married woman who graced our table. I often placed flowers in front on her plate. Of course, I never let on they were from me and I asked the landlady not to tell. The husband wanted to know who was so interested in his wife, and the other boarders all accused Mr. Ferguson, who later told me, "As long as I'm being accused, I'll send her flowers too." Sure enough, he had the landlady place three red roses in front of her plate every second day. Then when he learned that her favorite flowers were carnations, he sent her three or four of those several times a week.

Finally the husband became really alarmed. He confided

to me, "Charlie, I don't like this." I told him, "Look here, fellow, your wife is very pretty, and don't spoil your happiness on account of boarders sending flowers to her." Though he was ready to change boardinghouses, I talked him out of it. I pointed out that Mr. Ferguson was in the city only temporarily and "no matter where you go everybody will notice that you have a very pretty little wife and this same thing will be repeated no matter where you live."

Mr. Ferguson was a real gentleman. He always seemed to be occupied reading books and reports. He had sharp, observing eyes, and in any conversation he was outstandingly intelligent, though somewhat reserved. One day he did not show up for lunch, and about one o'clock that Saturday noon—I remember it was a rainy day—there was excitement in the neighborhood when two "paddy wagons," drawn by two white horses, each with bells ringing, pulled up as if there were a roaring fire in our house. We all looked at each other. At first we thought it was the Fire Department because the bells rang loud and long. We were still at the dining table when a voice commanded: "All stand as you are; everybody pile in the police wagon. Leave your hats and coats, just come as you are down to the police headquarters." I told myself, it can't be because I sent carnations to the lady. At the police headquarters we were all questioned separately: What do you know about the little woman and her husband? I was the first to be called before the captain of detectives because I was known to be friendly with the couple. There with the police captain was "Mr. Ferguson." It turned out he was a special agent of the U.S. government. I, of course, had only the very best recommendations for my friends who, it seems, were accused of making counterfeit twenty-dollar bills. They were very clever—the money was near perfect and it had taken the government three years to catch up with Mr. and Mrs. Money-makers. All the boarders were questioned and released. No one knew anything about the counterfeiting. The couple did not even pass any of their money to their friends in the lithograph shop. Among the printing presses were found several thousands of dollars in counterfeit money. He received twelve years and his wife six years, and

this ended my innocent boardinghouse romance that I shall never forget as long as I live. Whenever I see white carnations I always think of this couple.

↑ ↑

I always enjoyed good Hungarian food so I always looked for Hungarian restaurants. In one of the places where I ate for several years there was a great deal of hushed conversation to the effect that "if our uncle should ever die we will be left quite a sizable fortune." I could not figure out who this uncle was, but they did speak a lot about a man by the name of Kecskemeti who was very rich and would some day leave everything to them. I discovered to my great surprise that the reference was to a once highly-respected, now notorious Hungarian mailman, the money order postman, implicitly trusted at one time by the Hungarian government. Forty-five or fifty years ago he was to deliver to a large Hungarian bank 500,000 *krona* in silver coins, about \$125,000. This was a lot of money fifty years ago, and carrying it presented a real problem. The mailman disappeared and the government offered large sums of money for information leading to Mr. Kecskemeti. He was thereafter "seen" nearly every day. Though reports of his whereabouts continued to come in for fifty years, he was never found. He was supposed to be living in New York or somewhere in the United States. Other reports placed him in Rio De Janeiro, Sao Paulo, Buenos Aires, Africa and hundreds of other places. Only his relatives, with whom I was friendly, knew of his whereabouts, and only I was their confidential friend. The biggest mystery was, how did he carry so much silver on his body?

Fifty years ago our government's extradition agreement with the Hungarian government applied only to those charged with murder, and somehow Kecskemeti managed to elude every trap that was set for him. Kecskemeti died in Brazil a poor man under an assumed name, about thirty years ago. Thus ended the search for the mailman who stole the largest amount of silver coin ever—and got away with it.

A second mailman, fifteen years later, tried to benefit by the example of the first. The man's name was Postpishil. He varied the procedure by disappearing and faking a holdup. He claimed to have been held up, robbed and held prisoner for three or four days by unknown men. For three days the entire Hungarian police force looked for him, calling him Kecskemeti the Second. During the time he claimed to have been abducted he buried his treasure in the Hungarian Bakony Forest. Satisfied as to its safety, he emerged from the forest to tell his story. His horses and mailwagon had been found two or three days earlier. He came out of the woods shaggy, hungry and, to all appearances, partially unbalanced. His pants were muddy from his digging. The government, in the interim, had dispatched men to all parts of Europe, to every steamship company, to every railroad station leading out of Hungary; looked into every farmhouse on his route, asked everybody along the way whether they had seen him. No one had. When he did make his appearance, at a farmhouse, the farmer immediately informed the dreaded *Zsandarms*. Fifty officers rode back with him, surrounding the small stable, fearing the mailman was armed. They shouted to him, "Come out of your hiding place!"

Postpishil yelled back, "I am not hiding, I am only resting."

They placed cuffs on his hands and feet and arrested him. Under cross-examination, Postpishil stuck to his story. They continued to grill him. Finally, the mailman broke down. He said no one had held him up, that he had faked it himself. But he said he had lost track of the spot. After much searching, the cache was discovered. The mailman cried bitterly. He had planned to take the money out of the country, a little at a time. The newspapers jokingly suggested his election as finance minister because he guarded so large an amount of money so carefully without losing a cent. When asked what impelled him to do it, he replied that he had been impressed by American Western mail-robbery stories.

His twenty-five-year jail sentence provided him with ample time and opportunity to pursue his reading.

✓ ✓

Boarding life had its ups and downs. A boarder was, by turns, a second husband or stepfather and stepmother, judge, peacemaker and all-around errand boy. "Say, Charlie," the request began, "on your way home will you bring me a loaf of bread?" "Say, Charlie, I don't think I will have enough onions for tomorrow." "Will you put a couple of pails of coal on the stove in the parlor?" "The little boy is crying, will you make him dry? I have to hurry with my supper." "Be a nice boy, help me with the dishes." "Be a good boy and take the clothes off the line." "I have not been out with Anton for a long time. If you are not busy, please take care of the kids; don't forget to give them *shmalz brod* at 4:30. We will be home for supper; if you don't mind, put up a pot of potatoes so they'll be ready by the time we get home." I was, among other things, called upon to name a baby girl. I called her Martha. I designated one boy Joska, a popular name in Hungary. I had to write letters and take notes. But when I look back now, the poor landlady who washed and ironed the clothes for four or five boarders and her own family, with no washing machine or ironing machine, who washed the dishes with no dishwasher, deserved any help we were able to give her. I was always willing to co-operate. I was reminded of my poor mother, who had nine children and no modern improvements; everything that I did for my landlady I learned at home.

✓ ✓

Still in Rochester in 1908, I got together with a fellow named Sabo who had an outstanding reputation as a tool-maker and designer and we started a tool shop known as the Eisler-Sabo Tool Co. However, Mr. Sabo did not seem to realize that bosses have to work harder than their employees in order to make up for the deficiencies of their workmen, to make up the difference between the unearned overhead and

a necessary profit. He did not or would not accept the fact that a small boss must work extra hard and take plenty of abuse, especially if something goes wrong. (In the eyes of the

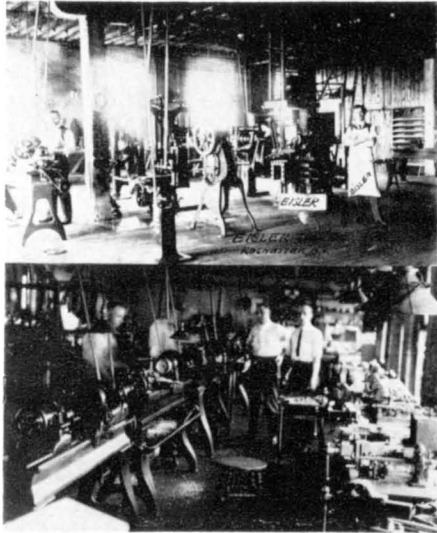

Above: The Eisler-Sabo Tool Co., Rochester, 1908. Eisler is at extreme right. *Below:* The Eisler Machine Shop as it looked in the beginning, in Newark, 1920. Kirk Alley, where it was first located on the top floor of an old loft, was also known as "Edison's Alley" until renamed by Eisler.

worker the boss gets rich on every job, no matter what the losses may actually be.) Also, a business must always get first call, and sometimes this upsets personal plans and family matters. A small boss's wife should not expect to see too much of her husband; his hours are not his own—he may have to stay late for any number of good reasons. It is not due to luck that a small boss may become successful—it is the result of hard work, and the concept that "the customer is always right." The worker should not begrudge a boss his success and the material wealth that follows; he can be sure that it was earned by working twice the number of hours as any man in the shop, including holidays, Sundays and nights.

Getting back to the Eisler-Sabo tool business, I found it very difficult to get along with Sabo, and this venture did not last long. Our company broke up and we sold it to a Mr.

Yawman, who kept me on as manager for a year and a half. During this time I did special work for others, among them Mr. Eastman, the camera man. However, I did not see a big future there so tried something else.

I left to take a job in Freeport, Illinois, with the Hoefler Manufacturing Co. The company had advertised for a factory foreman and I applied for the position. Mr. Hoefler told me that while I looked too young to be a foreman in a machine factory employing 150 men, it seemed to him that I had the experience and qualifications for the job. But he was afraid the older men might not take orders from a young Easterner. So he tried me for a month, and it worked out well. The men had a high regard for me, especially since I worked hard and long hours. After six months, I was keeping production on the increase and even making occasional improvements. However, I knew that the owner had a son who was about to graduate from engineering college, and I could see that there was not enough room there for two top men. It was good that I did not raise my hopes too high, for after I worked there a year the son came home from college with big ideas, and I left to seek a new position.



TO WHOM IT MAY CONCERN:-

This is to certify that Mr. Charles Estler was in our employ for one year and two months, during which time he acted as Foreman of our Machinery Department, in which all of our small work is done, and Estler was placed in charge of our assembling department, overseeing all work connected with the assembling and shipping of machine tools.

While he was with us, he had a very wide experience on different classes of work practically taking the parts from the rough stock, and bringing them through to finished material, even including jigs and fixtures to assist in finishing up the material.

All the experience he had in our plant, should be of great assistance to him, and we believe that whoever employs him, will find him an efficient workman, capable of seeing that the work proceeds in a satisfactory and orderly manner.

Yours very truly,

HOEFLER MANUFACTURING COMPANY

CAB-5

Freeport was a small town, and although the people were friendly there was very little for me to do after working hours. There were, of course, no movies then and also no bars in that Prohibition era. As you may have guessed, I decided to attend a night school in advanced machine design and engineering. Otherwise it would have been very lonely there. To help take some of the monotony out of small-town living, I also joined a singing club, and a social group called the North Americanischer Turn Verein. It was the only place in town that a young fellow in my position could spend his evenings or Sunday afternoons.



Sunday amusement in Freeport, Illinois.

Amusement consisted of horse-and-buggy rides about the town and countryside, the charge for which was something like a dollar for the entire day. However, since the girl I was squiring at that time had to be home before dark, I seldom drove later than nightfall.

1 1

Papers were full of the case of a Hungarian coal miner entombed for forty days and nights, gnawing his shoes, drinking the water that trickled through cracks in the mine. When the rescue squad reached him he was in bad shape, but he soon recovered. Although sixty years old, he had withstood the forty-day ordeal better than could many a young fellow. He had been in the United States for thirty years but spoke not a word of English, only Magyar. When he came out of the mine he was the miracle of the ages. Examined by government doctors and others, everybody marveled that he seemed

to be none the worse for the long fast and the other hardships he had endured.

One man, a promoter, had a good idea. They dressed the miner in a regulation miner's uniform—the kind you see in catalogs but which this miner had never worn while working. They placed a burning miner's lamp on his cap, and they shooed him into a nickel still-picture house. They paid him \$25 a week and he had a good time. When people asked him something in English he would just say "Hungarian"; this word answered all questions.

Every newspaper in the country bought his picture but few could describe his experiences, because he spoke only Hungarian. One day he came to a Freeport nickelodeon. There were few Hungarians in Freeport at that time. The house was packed when the manager said, "Ladies and gentlemen of the audience, is anyone here who can speak this man's language so the audience can ask questions? He speaks only Hungarian."

I got up and walked up the stage and said to the manager, "I think I can talk to him."

He said to me, "Are you sure? You don't look like a Hungarian—you're not a miner by any chance? I thought only miners were Hungarians."

I approached the Hungarian miner, and his manager said, "Now, young man, say something in Hungarian."

I said to the miner, "*Hogy van oregon?*" (How are you, old man?).

He replied in Hungarian, "I feel very fine; I have never felt better in my life."

After that everybody in the house had all kinds of questions to ask, all of which I interpreted. When the night was over I, and not the miner, was the hero.



It was in Freeport that I was transformed from a greenhorn into an American citizen. That great day—June 6, 1910—was one which I had long dreamed of, and at last the dream came true. I appeared in court to give the oath of allegiance and received my official citizenship papers. We celebrated at the

club, and I went home with real tears in my eyes. Now I was ready for bigger and better responsibilities, and I looked forward to a new job.

The first great day as a citizen of the United States meant very much to me as an immigrant. You cannot picture that feeling unless you are one of them, "an Immigrant" becoming an American citizen. That day meant very much to me because I dreamed of it all my life, from the time I was old enough to think of America. It was always my hope to live here. I did not want to remain in Hungary. I liked, and still like, the Hungarian people, but Hungary never offered much to its working people, of whom I was one.

As long as I live I shall remember the kind words the judge had to say on that day. He was a dignified gentleman and he said to the seven of us: "This is the United States Court where justice prevails to all alike. Please raise your right hand and say after me the oath of allegiance." We echoed the sacred words, and then the judge said, "Now you are all American citizens."

We sang the "Star-Spangled Banner" and "America I Love You," then we all went to the Turn Verein and toasted the United States and the judge who had sworn us in as citizens.

When I had received the letter from the Supreme Court to appear to take my oath, I said to my friends, "Just think, I am no longer a greenhorn, I will be a citizen of the greatest country on earth!" I was proud, happy and lucky; I knew people all over the world would give their all for such a paper from Uncle Sam. This paper has taken me to many parts of the world and has guided me safely back home to the good old United States, to my people and to the Statue of Liberty which to me means freedom, liberty, equality and justice for everyone, whoever he may be and where he may come from. Rich and poor alike, king or immigrant, the Statue of Liberty welcomes everyone alike. It is the torch of new hope and freedom for all who come here from all parts of the entire globe.

After our little celebration at the club, I went home and

for hours I looked at my newly acquired citizenship papers. I had tears in my eyes. Of course, I had no one to talk to when I got home. After all, I was only a boarder in the fine home of Mrs. Backer.

Her husband was a locomotive engineer on the Illinois Central Railroad. When he learned that I had locomotive experience, we had something in common, and whenever I was off Saturday or Sunday or had a free evening, I would join his run from Freeport to Chicago, a three-hour trip. He talked to me often about my taking a hand in that line of work, but I said to myself, Mrs. Backer always complains of his late hours. It is not the right kind of life for a married man. He is well paid, but he is rarely home at night or on Sundays with his family. So with tears in my eyes I went to bed, though I was the happiest man in Freeport. I was no longer a greenhorn. I was ready now for bigger jobs and greater efforts.

OFFICE OF DWIGHT D. EISENHOWER

*Hotel Commodore
New York 17, New York
December 31, 1952*

Dear Dr. Eisler:

I know I speak for all Republicans when I express my deep appreciation for the important part you played in the campaign.

Victories are won only with effective teamwork. We could not have succeeded without the knowledge, experience and devotion of the Republican organization, and I am proud to be its leader.

Heavy responsibilities now lie ahead for us. But I am confident that we will continue to devote our common effort to the single purpose of a better future for our country.

Sincerely,

DWIGHT D. EISENHOWER

If I had stayed in Hungary I am sure I never would have received a letter from the President of Hungary. They simply don't write letters to ordinary citizens. You can only expect that in a free democratic country like the United States.

1 1

I had heard from a friend of a very modern factory in Rockford, Illinois, which was only one hour by train from Freeport. I had already resigned from my job with Hoefler, and I arrived at Rockford determined to take anything that was offered me, especially when I saw how orderly and efficient-looking the plant was. It was called the Barber-Colman Co., and I obtained a position as toolmaker and tool inspector. After five months there the superintendent, C. R. Burt, was sufficiently impressed with my drawing and designing skill to promote me to foreman of a new department that would be building gear generators—better known as gear-hobbing machines. My job was to organize the new machine tool assembly department which, in addition to making the gear-hobbing machines, was to assemble production millers and special machines for the production of the new Model

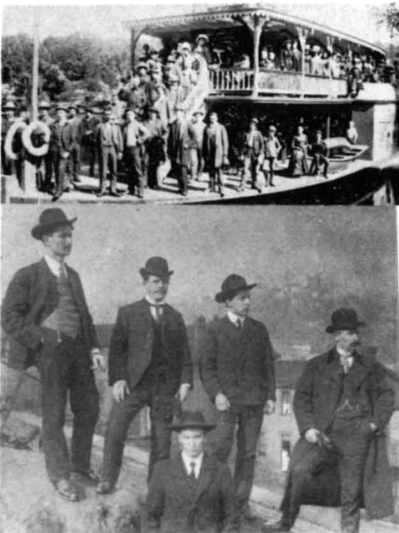

Above: I was one of these Barber-Colman employees on a Sunday outing by excursion steamer—a popular event in 1907. *Below:* Eisler, left, at 20 in East Pittsburgh, 1903, with friends.

T Ford car, which was shaping up in Detroit. This job and the company itself gave me by far the greatest prestige that I had heretofore attained.

Under my supervision the first gear-hobbing machine was built at the Barber-Colman plant—the first six and the first twelve. My suggestions were instrumental in bringing about a number of changes and improvements on the machines. All improvements and changes had to be submitted in writing to a staff of engineers and supported by drawings.

However, despite the fact that this was obviously a good position with a fine company, I could not become enthusiastic over my chances for any further progress. I was a foreman, but to advance from that position was extremely difficult and certainly would take twenty or twenty-five years. The competition was extremely keen in this company, and although Mr. Burt suggested that I stay on since he felt I had a good future there, after arguing with myself for weeks I decided to leave. I did not have the feeling that "this is it," and I felt that I would not make any position a permanent one until I had that feeling. Of course I was giving up a secure job and I might have been mistaken in believing that advancement

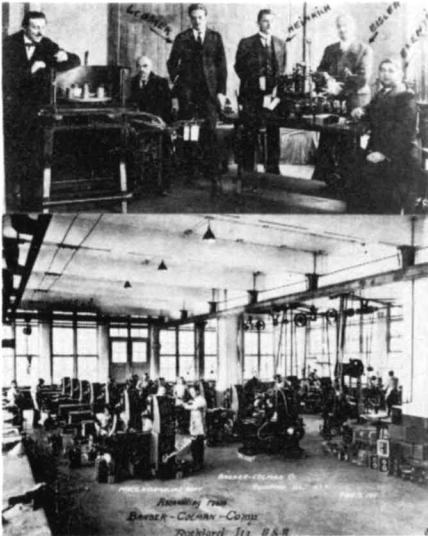

Above: Eisler lamp machinery on exhibit at the Foire de Lyon, Paris, 1924. Standing, left to right: Loomer, Heinrich, Eisler, Erenyi. Below: Barber-Colman Co. assembling room, Rockford, Illinois. Eisler, the youngest foreman in the plant (1910-12), in foreground in white coat.

was far off, but I had to take the chance. Since I was single, it was possible to come and go more or less as I pleased, and I stuck to my decision to leave.

As it turned out, I was right. I visited the plant some thirty years later, and although the company had quadrupled in size and now employed several thousand, all the men that I had known there years ago were still foremen. Not a bad job being foreman but it was the limit and I would have waited in vain for advancement. I have always followed my judgment in such matters, and it has always worked out for me.

Mr. Burt remained a close friend and even now, forty-eight years later, we still exchange Christmas and New Year's cards. He left the Barber-Colman Co. eventually, becoming general manager of Pratt & Whitney Co., and later chairman of the board of directors. He retired three or four years ago.

As for me, after six months as foreman, I left to go into, of all things, aviation!

6. I TRY AVIATION

By 1912, I had read so much about aviation—about what a terrific opportunity for quick success was offered in this brand-new field—that I decided to give it a try. I figured that with my engineering experience, eventually I should be able to build airplanes. I had a few thousand dollars in the bank, and I felt I could afford a temporary halt in income while I pursued this challenge of flight. It seemed to me that in order to build airplanes, I should know how to fly, so the first thing I did was to enroll in an aviation school on the outskirts of St. Louis, Missouri, known as the Benoist Aviation School. The instructor there was Anthony Jannus, a great aviator. We became good friends. In my first lesson, I noted that the plane seemed to be held together with wood struts, canvas, wire and electrician's tape. I was somewhat disappointed that it did not require the fine art of mechanical work that I knew. The tape and wire were of primary importance—in those days; if you had no electrician's tape you could not fly. When I saw how poorly the flimsy planes were constructed, I was sure I could build a better mechanical job if I had the chance. Except for those of the Wright Brothers, Curtis and one or two others, most planes at that time were put together by amateur mechanics. Of course there is absolutely no comparison between those "crates" and present-day models; even the single-engine private planes of today are precision-made and a thousandfold more complicated in design. The mechanical skill I had expected would be put into plane-making forty-five years ago has finally become standard procedure.

At any rate, our plane stayed up, and landed nicely. Jannus was an expert pilot—you might almost call him a genius. Once when I was up with him at 1000 feet, he deliberately



Above: Eisler at the stick of the student plane he helped design and build in 1912, at the Benoist School. *Below:* Dr. F. M. Bell and Eisler, St. Louis, 1912. Eisler made the design drawings for this plane.



shut off the motor and shouted to me how safe it was to vol-plane to earth without power. He made quite a name for himself in aviation's infancy—in fact, a group of historians have created a Jannus collection of early aviation pictures which are now on display in the Smithsonian Institution. My picture is also in the Smithsonian Institution collection, not because I was considered an aviator but because as a student flyer I happened to be in a picture with Jannus. Unfortunately, Jannus volunteered to fly in Russia during the First World War, and he lost his life when his plane fell into the sea in 1916. When I knew him he was twenty-two and he already had two years of flying experience; his license was, I believe, No. 105—he was one of the earliest of aviation's pioneers.

I soon learned that the only decent flying hours were between five and six in the morning and about six in the evening, when the air was very quiet. I spent about five months learning to fly, and I am sure we spent nine-tenths of the time repairing the recurring mechanical faults, or



Above: Eisler prepares for a short hop in Kinloch, Missouri, 1912; Benoist, left. Below: Lt. W. A. Capron and Eisler in a Benoist School plane, Kinloch, 1912.



Kinloch fliers at Benoist field headquarters in 1912: (1) Anthony Jannus, (2) Eisler, (3) Hillery Beachy, a stunt flier, (4) Robert, a test pilot, (5) a Roberts engine expert.

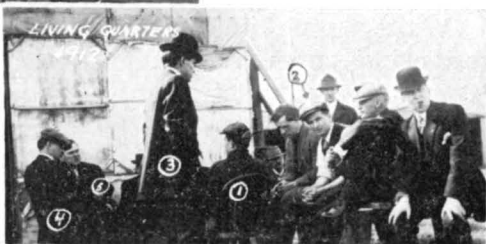

Above: Anthony Jannus instructing Eisler at the Benoist School, 1912. Below: Jannus and Eisler in the same plane that winter. Benoist pilots flew in all kinds of weather.



waiting for a new part or for good flying weather. Our plane flew about eighty-five miles per hour and required a perfect calm before we would even consider taking off. With the constant fixing—before flying, after flying, between flying—I became more discouraged every day. The hours of waiting were exasperating. Of course the reason the fellows put up with all this was that they all expected to make a fortune in aviation, in eventually building planes. During the winter most of us lived right throughout the week on the field in an unheated shack shared by about a half-dozen, in order to be on hand if flying weather was available. On weekends we stayed in hotels in St. Louis. One of my best friends in this group was a lad named Ed Korn, with whom I roomed when we were in town. We would often leave the hotel at 3 A.M. and make the hour's trip to the airfield.

While I was with the school, I helped design and build two planes, and helped with the woodwork. The earlier plane

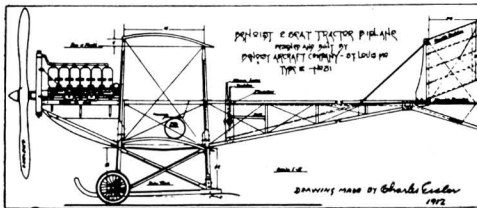

Eisler's original drawing in 1912 for the plane later built by Benoist students that year.

we used had the propeller at the rear, behind the motor, with the aviator sitting in the front on the open "porch." Even the newer puller type of plane, with the propeller in the front, did not offer any more protection for the pilot. It was terribly cold up in the air. There was no protection under the seat or on the sides; it was just like flying through the air on a stepladder. Several times I feared that I would freeze to death before I landed—the cold air and wind were unbearable, but it was considered good flying weather. Very often on landing my body would be completely numb, despite the lined leather suits. This misery was called aviation. It left

a very bad impression on me. I told myself: If a student doesn't get killed in a plane accident, he takes a chance of being frozen to death.



Eisler examines wreckage of the plane in which pilots Glaser and Wheeler were killed at Benoist School, May 13, 1912.

By the time I had soloed a few times, I was on the verge of giving up the idea of staying with aviation. What finally discouraged me completely was an accident in which two of the boys lost their lives. The students, Glaser and Wheeler, farmers from Oklahoma, flew into power lines near the airfield, cracking up the plane (which, incidentally, I had helped to build). Wheeler was killed instantly; Glaser was badly injured and died three days later. This experience took the remaining enthusiasm for aviation out of me, since it also meant that I would have to wait around for six months while the school built another plane. I felt that now was a good time to leave, while I still had a few dollars to my name. I never did get my license.

/ /

Recently I saw an article in a Newark paper that the "Early Birds," the old-time aviators who were trained before 1914 (of whom there are only a few still living), were in town for a reunion. I saw the name of Edward Korn, and it registered in my memory.

I called him on the phone and asked, "Are you Edward Korn, my roommate in a St. Louis hotel in 1912—an aviation student from Ohio?"

He replied, "Yes, Charlie, that's me."

We got together that afternoon, meeting for the first time after forty-five years. It was a wonderful reunion. Ed, it turned out, had gotten his license many months after I left aviation. His number was 119. But shortly after this he was in an accident with his brother Charlie. The latter was killed and Ed lost a leg. Since then he successfully built several planes, eventually going back to college for his M.D. degree. He is now a practicing physician in West Orange, New Jersey.

Dr. Korn suggested that I too apply for membership in the Early Birds. Members had to have soloed before 1914, and since I flew in 1912 I was accepted by the organization.

I did not regret the time I spent at the airfield or the money it cost me. If I could have made the right connections—perhaps a better school—I feel I could have gained some success and probably gone into the building of airplanes. But this experience must be chalked up as my first setback, since everything I had done previously had afforded a substantial degree of progress for me. Unfortunately aviation was not for me.

I wrote to my friend C.R. Burt, the manager at Barber-Colman, and told him of my lack of success. He happened to know of an opening in Detroit for a toolroom foreman with gear-hobbing experience, and he suggested I try it. I went to Detroit, with an impressive letter of recommendation from him, to the Metzger Motor Car Co., and was hired at once. I was put in charge of the tool designing department and the toolroom. It was a very good position while it lasted—but it didn't last long. Detroit's automobile industry was just beginning. It was 1912, and auto factories were beginning to work seven days a week, fifteen hours a day—prosperity was a reality. Of course, at that time the workers did not have their own autos; I drove out but it was a test car belonging to the company. With about three hundred men, the company built about twenty-five cars a week. It cost more to build them than they were selling for, and the company was in bad financial shape. It finally was absorbed by the Studebaker Corp. This merger of necessity eliminated or downgraded many of the Metzger engineers, foremen and tool-makers, since Studebaker had its own staff. I could not see

much future for me there. Most of us worked every night and all day Sunday without extra pay, just to help matters along.

But I finally left the company. In the six months I was there, I had put in a year's time, with night work and all, so I thought I'd take a little rest. Then and there I decided on a trip to Europe to visit my people. They had written often, expressing a desire to see me, and after ten years I felt it was about time I visited them.

7. A VISIT HOME

I WAS twenty-eight, an American citizen, and I knew I could come back any time I wanted to. It was a wonderful feeling for one who was not a native of the United States. So, for a "change of scenery," in the spring of 1912 I left on a steamer for Europe. I intended to make the visit a short one, but while in Budapest I took a very good position with a large electrical firm as a tool-designing engineer, and the "short visit" lasted two years.

On the boat going to Europe I met another Hungarian, a miner whom I had known before in Freeport. We spoke together often, meeting on deck almost daily. He had not been home—a little farming town near Kecskemet—in twenty years, and he told me he couldn't sleep nights any more; he could hardly wait to see his mother and father again. What made his return even more unusual was that he had not written to his folks for these twenty years; he had left them with the impression that he was sailing to America on the *Volturno*, which sank with all hands lost, and he did nothing all those years to correct the idea that he took that boat. He always felt that the surprise would be that much greater for his parents when he returned and especially now after twenty years, since they believed him to be dead.

He often pictured how it would be to embrace his mother again. He planned to throw a big party; everyone in the village would share this great feast—"the likes of which the town has never known or will ever know again." They were going to kill hogs; wine was going to flow, gypsies were going to play. The whole village was going to be invited; he wanted everyone in town to remember the party as long as they lived.

He was about forty-two and had never married; he had saved all his money with only the homecoming in mind. He

showed me where he carried several thousand dollars in the wide belt around his waist. I told him not to tell anyone he had so much money on him, and not to go drinking. He assured me that this hard-earned money would be kept safe until he got home. He wanted everyone there to remember him, since he did not plan on staying, but intended to return to the United States. He had it all figured out: It was his intention to fool everyone for a week or two, acting as a stranger in his village and letting them guess who the stranger was. His homecoming would be a real surprise in the village where everybody considered him lost. Nobody would suspect who he was.

The steamer finally arrived in Europe and I wished him good luck and safe arrival home. He nodded and said he hoped to see me again in the United States.

A few weeks later I saw a headline in the newspaper: "American Visitor Murdered." The story mentioned that a stranger—"a bum"—was killed by an unknown assailant in a hay barn. When I read the name of the little town, I realized it was my friend from Freeport. A farmer and his wife had reported the killing to the police. There had been a long investigation and I read the following account by the authorities.

It seems that a stranger, acting very peculiarly, had come to their house. He said he was a wanderer, looking for a night's lodging. Although they had a spare room, they told him he could not sleep in the house, but that he could stay in the barn, in the hay. After they showed him to the barn, he said to the woman—*she was his mother*—"Lady, I have a little money here all tied up in a handkerchief; it will be safer in the house than here with me in the haystack. When I leave in the morning please give it back to me." She took the bundle of money and, once in the house, she and her husband opened it. When they saw the large amount of Hungarian currency and American dollars they ruthlessly decided to do away with this "wandering stranger" and keep the money. After midnight, when the fellow was sound asleep, they both entered the barn and did him in with a hatchet. They left the body until morning and then reported

to the police that the stranger had been killed by some unknown assailant. It was only when the papers on the body were examined that they learned that the "wanderer" was their long-lost son. Overwhelmed, they confessed to the killing of their only son who they thought had been lost on the high seas twenty years before.

This ironically ended the long-planned homecoming party for the Hungarian miner.

1 1

When I arrived at the Eisler home in Budapest, there was a joyful, tearful reunion. Everybody had grown older, of course. The little brothers had grown up and I did not recognize them; they claimed they never saw me before. The daily crying became so intense I could not live at home. My mother would get up at night, sit by my bed and cry with joy to see me again. She would go through the same thing when she fed me. I finally had to move out, making up some excuse about going to live with a school friend who had a beautiful apartment going to waste.

When I had been in Budapest about ten days, I noticed the following advertisement in a German newspaper: "Tool-designer, constructor with at least ten years tool-designing experience in the United States, wanted by a firm with American connections. We are looking for an engineer who speaks Hungarian, German and English." I told myself—"I'm just the man this ad describes—made to order, with all the qualifications!" Having convinced myself, I hastened to the company, which was the Standard Electric Co. at Ujpest, an American-owned plant and the largest of its kind in Europe. It was a beautiful plant, employing three thousand people and located on the Danube. I was interviewed by Hegedus Miklos, the plant manager, who also spoke Hungarian, German and English. The result was that I was engaged as tool and machine designer in the railway and telephone manufacturing department. I was assigned a comfortable private office and the pay was very good. Hours were from eight-forty-five to five, with a two-hour lunch period.



To Whom it may concern:-

This is to certify that the bearer, Mr. CHARLES EISLER, was engaged with the above-mentioned firm, from May the 2nd 1912 until April the 30th 1914, during which time he acted as Designer and Constructor of tools and Special machines, for manufacturing interchangeable parts in a modern up-to-date manner.

While with us Mr. Eisler has designed all the necessary tools, jigs, fixtures and special machines for our products in a very satisfactory way.

We found him honest and reliable, and all his designs were up-to-date in every respect. We do not hesitate to recommend Mr. Eisler to anyone desiring a first class up-to-date tool designer. He left to return to America.

Yours very truly,
 UNITED INCANDESCENT LAMP AND ELECTRICAL COMPANY LIMITED

A view of Standard Electric Co., Ujpest (also known as United Incandescent Lamp and Electrical Co.) is shown in the letterhead of this 1914 appraisal of Eisler's two years of service (1912-14). Eisler designed his first lamp machines here.

Of course, while the manager was perfectly satisfied with the verbal information I had given him about myself, I had to produce something in writing which would attest to my ten years of American experience; so I wrote to the Studebaker Corporation in Detroit, the Barber-Colman Co. in Rockford, the Hoefler Manufacturing Co. in Freeport, and the Eisler Manufacturing Co. in Rochester. They all sent me letters verifying my employment and indicating that my work had been more than satisfactory.

In the winter I would ice skate daily during the lunch hour. In the summer, before and after work, I would enjoy an hour's stroll along the Danube, or I would spend many a lunch hour with some of the other department heads motor-boating on the Danube. Because of my knowledge of the three languages, the general director often assigned me to

B. Y. C.
TRADE MARK
BARBER-COLMAN COMPANY
MAIN OFFICE AND FACTORY
ROCKFORD ILL.

August 5, 1912.

TO WHOM IT MAY CONCERN:

We recommend Mr. Charles Eisler as a first class mechanic and excellent workman. He left our employ on September 22, 1911, and while with us he worked about twelve months as a toolmaker and six months as foreman.

We found him faithful, honest and reliable, also a desirable workman, and we would be glad to re-employ him at any time.

BARBER-COLMAN COMPANY

E. R. Burt
Superintendent.

FRANK S. YAWMAN, President

STEWART W. ARTHUR, Secy. and Treas.

EISLER MANUFACTURING CO.
Special Machinery
METAL SPECIALTIES PUNCHES AND DIES
109 Hague Street

ROCHESTER PHONE 3848-L
WELLS PHONE 918 GUNBERG

Rochester, N. Y., May 15, 1913.

To Whom it may Concern:-

This is to certify that Mr. Chas. Eisler was Manager of our contract shop for about one year and a half during which time he acted as estimator and designer of Punches and Dies, Jigs Fixtures and Special Machinery. While with this firm his work was very satisfactory. He left to accept a position with the Hofer Mfg. Co., Freeport, Ill.

EISLER MANUFACTURING COMPANY

FOT/R

Per *J. M. Furman*



DETROIT, MICHIGAN.
U. S. A.



Aug. 7th, 1912.

Chas. Eisler,
#126 Lajos Street III
Budapest, Hungary.

Dear Sir:-

Attached you will find recommendation for which you asked and which it gives us much pleasure to write.

Yours truly,

THE STUDEBAKER CORPORATION
E-M-F Factories.

Chas. Gordon
Production Manager.

CG/AJC

THE STUDEBAKER CORPORATION

E-M-F FACTORIES
DETROIT, MICHIGAN.
U. S. A.



TO WHOM IT MAY CONCERN

This is to certify that Mr. Chas. Eisler was General Foreman of the Tool Room at the Plant of the Metzger Meter Car Co. for a period of about six months, during which time he gave excellent satisfaction. He was rated at \$35.00 per week and left to take what he considered a better position.

THE STUDEBAKER CORPORATION
E-M-F Factories.

Chas. Gordon
Production Manager.

CG/AJC

August 7, 1912.

These letters were mailed to the author in Budapest, 1912-13.

receive American and English visitors to the plant and entertain them after work. This was no problem in Budapest, for in 1912 the city boasted of the best night clubs, coffee houses and gypsy music in the world.

All in all, I was tempted to remain a "fixture" there, but my heart was not in Hungary. I thought only of the United States, of the great possibilities there. I felt that it was there that my turn would come some day.

8. I GET MARRIED

ALL THE time I was in Budapest my mother was after me to think about finding a wife. She kept reminding me that I was going on twenty-nine and I should not remain single, because "when you get old you will have nobody, and every decent boy should have a wife and family." I heard this same speech almost every day. A few days after I celebrated my twenty-ninth birthday, she mentioned that the next-door neighbor had a very nice-looking daughter, about twenty-two, just the girl for me. She suggested that I go to the house, just introduce myself to her mother and then meet the daughter. At last, after long coaxing by my mother, I went to see the "neighbor's daughter." She *did* look very good; she was young and sweet—a nice type. She spoke Hungarian and German, and a little French and English—just a few phrases. I remembered her when she was five or six years old. Her father was a well-to-do merchant, and the family was comfortably situated. Her parents were fine people; they loved the opera, fine food, and their two children Arnold and Frieda shared their parents' interests and were accomplished musicians.

I began seeing her regularly, and it was not long before we were engaged and married. Before I asked her to marry me, though, I saw her several times around six in the morning, on my way to work. My friends had warned me: "Why don't you see her early in the morning? You may feel differently about her." When I did see her occasionally at that hour, she looked good to me—always neat and tastefully dressed. Of course, she did not have to lift a finger with the household chores—they had a cook, a laundress and a housekeeper—and she had plenty of time for her piano. When we decided to get married, I convinced her that she must be

ready to go back to the United States with me on short notice, whenever I decided to go. She wept at first, saying, "How can I ever live without my mother?" But she finally agreed. We kept this from her folks as long as possible because we knew they would not like the idea.

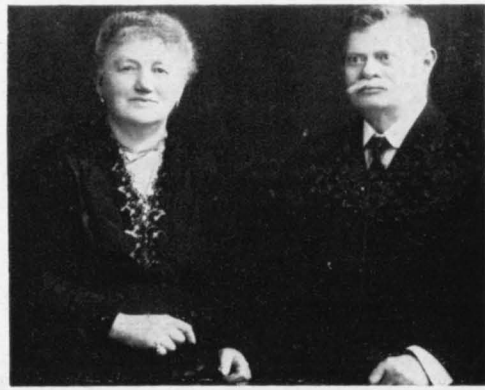

Julia and Gábor Schwartz, parents of Frieda Eisler, Budapest, 1928.

We were married in Budapest on December 24, 1912—Christmas Eve. We left the next day for Italy—a sixteen-hour trip by train and boat—where we honeymooned for two weeks at a place called Abacia, on the Adriatic Sea. While it was icy winter in Budapest, the climate in Italy could be com-



Frieda and Charles Eisler on their wedding day, Budapest, 1912.

pared with that of Southern California or Miami, with oranges and lemons ripening on the trees—all very beautiful.

When I returned to work, I told myself, I'm married now, which means more work and no more wandering around, trying different jobs. From now on I would have to stay put. But this decision did not alter my intention to return soon to the United States.

Late in the fall of 1913 Frieda gave birth to a boy. We named him Charles Jr. When I first saw him he was about five hours old, and I was very much disappointed in what I saw; he was premature and weighed only four and a half pounds. The only word to describe him was tiny. But the



Above: left, Frieda Eisler and two-week-old Charles Jr., Budapest, 1913; right, Charles Eisler at the age of thirty, Budapest, 1913. Below: The Eisler clan in 1953. Mr. and Mrs. Eisler are seated with their youngest grandchildren around them.

doctors said that he was perfect in every respect and that I should not worry—some day he would be as tall as his father, and probably stronger. (When I think back now what a little fellow he was, it is almost impossible to believe that today he has a family of his own, and is president of the company that I organized thirty-nine years ago. No one knows what the future has in store for us. Life is a fascinating gamble, filled with many chances, and it happens more often than not that the gambler wins. I myself have gone on many adventures, and in the long run I am not sorry for the dif-

ferent things I have done. Good or bad, it all comes under the same heading: experience. Now, at the age of seventy-five, I am still experimenting and experiencing.)

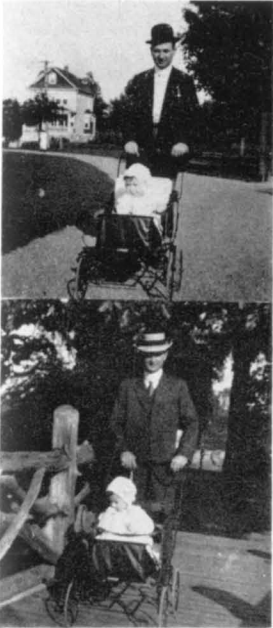

I model hat styles of the period as I wheel Charles Jr. in his carriage in New Jersey: (above) in Watsessing Park, July 20, and (below) in East Orange, September 7, 1914.

Finally the day came when I had been with the Standard Electric Co. for exactly two years, and I felt this was the moment to leave. The firm, which was also known as the United Incandescent Lamp and Electrical Co., Ltd., gave me a sizable and quite unexpected bonus when I left, along with a fine letter of recommendation. The next step was to make immediate preparations to sail for the United States.

I told Frieda's parents that we were both about to leave for America, and the news hit them hard. They cried almost continually until the day we left. My own parents, when I informed them, reacted in much the same manner. Frieda's father and mother felt that they were losing their young daughter, since we were going so far away. I was immediately sorry that I had given them two weeks' notice of our leaving—they were the most miserable two weeks I have ever spent.

Their maid Katty, who had been with them for over forty-five years, gave me the greatest difficulty. Whenever I entered the house those two weeks she would kneel in front of me with her rosary in her hand and cry, "Károly, how can you do this to us—take our only girl away?" I had to face this daily. When at last Frieda and I got on the train, we both broke down, mostly in sympathy with the heartbroken families; I must admit that I was really glad when the last good-by had been said.

When we left Europe in May 1914 it was like a perfectly-timed exit. Four weeks later came the assassination which triggered World War I. Remaining a bit longer would have meant staying for the duration—and possibly forever. It was with the feeling that luck was on my side that I sailed for America with my wife and our four-month-old child.

9. *A FRESH START*

WE ARRIVED in the United States and I was faced with the immediate problem of finding a good job. I had to make a new start at the age of thirty-one, with very little money and no "connections." We disembarked in Hoboken, New Jersey, and Frieda sat on our trunk while I went to look for a place to live for the time being. While waiting for me to return, she walked around the station and spied a horseshoe in the road. It was not embedded in rose petals but she picked it up, cleaned it, and kept it as her own good-luck charm. Since that day we have carefully preserved it and it occupies an important place in our home.



The Eisler good-luck charm was found by my wife in 1914.

When we were temporarily settled, I placed an ad in the paper and also visited several large electrical plants, seeking

work. Of the few offers I had, the most interesting seemed to be from the Westinghouse Lamp Co. in Bloomfield, New Jersey. They wanted someone with just the experience I had gained in Budapest — machine-building for incandescent lamps with tungsten wire. I was taken on by the company, and we moved to Bloomfield.

Although Frieda was automatically an American citizen by marriage, she was still a “greenhorn” in many ways. She didn’t know a soul here, and since she could not speak English she could not talk to anyone. She had left a comfortable home, and here she had no maid, cook or diaper service. She was also unhappy because I spent many nights working at home, which meant no social life or the opera she loved. Most of all she was very homesick for her mother. All I got for breakfast and supper was “I want to see my mother.” I think that if it had not been for the war, I would have let her go back to her mother so I could work in peace. Fortunately, I met an old friend named Fox, whose wife spoke German and Hungarian, and since they lived nearby things soon quieted down a bit. Mrs. Fox was a great help, speaking to Frieda in German or Hungarian, showing her where she could shop, what to buy, how to cook, etc. But when the novelty had worn off the same cry was started again, and there was no letup until the war had ended and it was possible again to travel.

Meanwhile, I was busy working at the Westinghouse Lamp Co. During the two years that I had worked for the large electric plant in Ujpest, I had made several improvements in design on various machines, and also contributed several completely new ideas and designed some original machinery — everything from gap coil-winders to stem machines and sealing-in machines—all of which increase mechanical output by automatic processes instead of hand operations. I designed quite a number of interesting automatic machines, but I am sure that any tool or machine engineer could have done the same. I was the first man given the problems and so I was the first to solve them.

When we left Budapest for the United States, I made sure to bring along all my samples, the products of every machine and the drawings I had made. Once I was in the office of

Dr. R. E. Myers, chief engineer at Westinghouse Lamp Co., I showed him all the drawings and samples, and two days after my arrival in the United States I started working for Westinghouse.



Dr. R. E. Myers, chief engineer at Westinghouse in 1914, engaged me to design lamp machines.

I was given a drawing board and assigned to make a tungsten filament coil-winder. I worked on this project for many weeks. When at last the completed design was tested it was found to be successful—the first automatic filament gap coil-winding machine in the United States.

An interesting sidelight on the manufacture of this machine is that its actual construction was done not by Westinghouse but on the “outside,” in a Newark machine shop. The reason was that those in charge of the Westinghouse machine shop did not approve of my project. They were convinced that any design made by a European-trained engineer would not come up to their standards. Since they would not cooperate in making the machine, it had to be elsewhere, done in strict secrecy. Only the chief engineer, Dr. Rem, and I knew of this work. I spent many nights each week overseeing the construction in Newark. When it was finished, the sample machine quickly proved itself, and after I made a

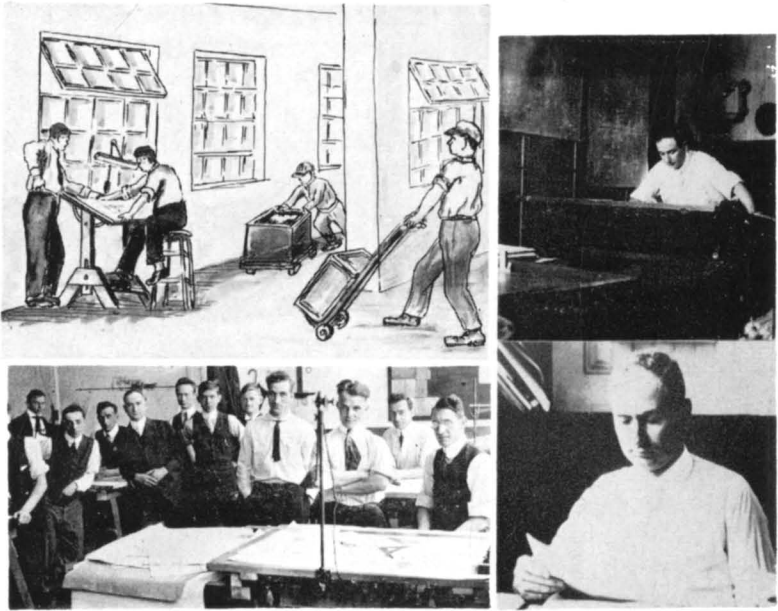

Above: (left) My first drawing board at Westinghouse was in a crowded corridor connecting two buildings; here, in 1914, I designed many of the machines which shaped the industry for years to come; (right) young Eisler at his drawing board. Below: (left) Eisler, fifth from left, as Westinghouse chief engineer in 1915; right, at work as chief engineer in 1916.

few minor improvements we had six more made by the Newark company, and then another six.

Hungarian lamp-manufacturing methods were about three years ahead of those in this country; when I started at Westinghouse coils were made by hand, as were flares, stems, sealing and many other operations. I began doing at Westinghouse what I had been doing the two years earlier in Hungary. I had no new problems; I simply improved on those Westinghouse hand-operated machines, converting to automatic machine work. The Westinghouse Lamp Co. got the benefit of my previous experience, and at no additional expense to them, since no experimental work was necessary. The only difference was that in Ujpest I worked in millimeters and spoke German or Hungarian; in the United States I worked in inches and spoke English. (Looking back

now, it seems that Westinghouse should have been the last company in the world to complain about "patent infringement" since they received practically as a gift the benefits of the machines I designed and continued to make improvements on during the five years I worked for the company.)

This was the time the first 75- and 100-watt tungsten filament and coiled filament lamps were placed on the market, and a tremendous demand was created for coil-winding machines. We ordered six new machines each month from then on. This Eisler-designed coil-winder became the most popular in the industry and it has since been copied all over the world.

When the first machine came from Newark to Westinghouse it was still a "secret," and I operated it all myself. For a while, except for a few key men no one knew that the coils we produced were made on an automatic machine. Operating these machines alone meant long night hours without pay, and I never asked for any, since my satisfaction came from being of help to the company.

After running the machines for almost two years, I finally convinced my supervisor that I would be even more valuable to the company if I could spend more of my time designing and building new types of labor-saving equipment. There was no difficulty in finding new fields to conquer; any engineer worth his salt and who was truly interested in the challenge could have done what I did, since in those days there were innumerable places in the plant where labor-saving devices could be installed; most of the old hand-operated jobs could easily be turned into automatic or semi-automatic machine jobs.

By the time twenty coil-winders had been installed, all company opposition to my designs had disappeared. Two years later, when I had designed several other pieces of equipment and they had proven satisfactory, I was authorized to organize an equipment-engineering department, the first one at Westinghouse Lamp Co. Before this, the company had depended entirely on General Electric for equipment; after the establishment of this new department we began making some of our own machines, with very good results.

Two incidents were responsible for the gradual change

in my feelings toward the company. The first was concerned with a company bonus of ten dollars which was offered as an incentive for punctuality and attendance. The sum, which represented a substantial increase in 1916, was awarded to every employee who punched in on time for a particular thirty days. During that month, I was sent on business to Cleveland for four days by the company. This mission involved many hours of work in the evenings, writing up reports, etc. For this I neither asked for nor received any extra compensation. But when I got back and finished out the month, I learned that because I had not punched in at Bloomfield for those four days, I was ineligible for the bonus. My explanation that it was physically impossible to be in Bloomfield and Cleveland at the same time had no effect on my supervisor. He passed the buck to the general plant manager but my explanation was to no avail. He could not do anything about it. No ten dollars. This incident left a very bad taste in my mouth; I was working for a company whose management had to consult with two or three top officials to decide on a question of ten dollars for one of its chief engineers (which rank I held) who had spent several nights on the train, two nights preparing data, and had produced labor-saving devices for the company's benefit while working late almost every night without pay. If such a company could benefit noticeably from increased production and then quibble over a ten-dollar bill, I could not see any great future in it for me. I began to change my attitude from one of great ambition to one of merely giving the company its money's worth. This meant much less night work on my part.

The second incident occurred when I was told by one of the officials that a vice-president of the company was interested in seeing the new coil-winders, which I was operating single-handed at night. A patent taken out in my name, of course, had been assigned to the company, but the patent (No. 1,338,498) clearly stated: CHARLES EISLER, INVENTOR. I was instructed by the department manager to have seven or eight of them running late one evening when the gentleman would be driven over after a dinner he was attending. At about 10 P.M. there was a knock on the door of my little room where

I was operating eight of the machines. When I opened the door, my superior stood there with the vice-president. I expected to be introduced to the man, or at least have my superior say, "By the way, Mr. V.P., this is the man who invented and developed these machines." Instead, all he said was, "I did this and I made this, and now I am making a few other sizes," etc.

In fact, he did not have the manners or decency to notice my presence. He must have taken me for a dumb foreigner; it certainly was stupid of me to do all this extra work without any compensation. When I related the incident to the chief engineer, he told me, "That's the way it is here; don't expect any pat on the shoulder when you make something. Keep your chin up, work hard, expect nothing. But your work will be noticed here finally—they can't help it."

This company attitude certainly dampened my ambition. Although a short time later I was placed in charge of a large machine shop as chief engineer of equipment, I just could not plan a future here. But I made up my mind to keep working until something better showed up. It was not so much the pay that bothered me, but a man wants recognition for his accomplishments, and when this is not forthcoming, he begins to look elsewhere. Recognition is essential to continue one's ambition and to maintain production improvements at top level.

10. *THE FAMILY GROWS*

WE HAD another addition to our family. Frieda gave birth to a girl, Martha, in 1915. She now had her hands full with two children, and much less time to be homesick for her mother.

I can still recall many incidents with the children which livened our existence and contributed to our store of memories. One spring when Charlie Jr. was about three, I took him for a stroll in his carriage through the nearby woods. We happened to pass a cherry tree, growing wild near the road. The boy saw the cherries and started to cry for them, so like any good father I climbed on the tree to pick some for him. Two days later I was a mess. My feet, legs and face were full of blisters. I did not know what was wrong with me; I only knew I was a very sick man. I had never come in contact with poison ivy before.

One summer, a year or two later, we were invited to the seashore for a few days by our friends Mr. and Mrs. Fox. We had never gone ocean bathing before, nor had we ever heard of sunburn, but when that day was over we had more than our share. My wife's arms, legs and face were twice their normal size; Martha, only two, was in even worse shape. The whole family was in bed for a week. But Fox, who was an "old hand" at the shore, got the worst sunburn of all; he was in bed for two weeks with painfully swollen arms and legs.

/ /

I was having my own "memorable experiences" at this time, completely unrelated to the children. With many of the other engineers of the Westinghouse Lamp Company, I had joined the National Guard. In 1916 the Guard was proclaimed by President Wilson to be part of the Regular Army.



Above: (left) The Eisler family in 1915, the proud father holding the infant Martha; (right) Mrs. Eisler engaged in her favorite pastime of embroidering, South Orange, 1937. Below: (left) The family car in 1918 was a Dodge; (right) Eisler with daughter Martha, Bloomfield, 1915.

I had been told it was a state law that the National Guard was for home defense only, and it was on the strength of this that we all had joined it. But for a short while at least, we were treated as Army recruits and, while brief, this experience was a miserable one. We were sent to Sea Girt, New Jersey, for eight weeks, and for the first four weeks it rained every day. All I saw was mud and more mud. Ankle-deep mud for walking, and plenty of mud for sleeping. I was full of fever blisters, and I don't think I could have lasted another four weeks. The Westinghouse Co. requested my release on the grounds that I was doing important work, and on my constitutional rights that I was not a regular soldier but only a National Guardsman. After six weeks I was released and I went back to my job at the company. A number of the men who belonged to the National Guard were also



Charles Jr. and Martha as "recruits" (*left*), and in mufti (*right*), 1917.



Frieda Eisler (*left*) is shown (*right*) with her husband and (*below*) in a 1917 family group.



This family group, taken in Newark as a surprise for my fiftieth birthday in 1934, includes (*left to right*) Connie, Ruth, Martha and Charles Jr.



Eisler (second from right) doing military service in 1916.

Charles Jr. visits his father's camp at Sea Girt, New Jersey, 1916.



released, as well as those with families and those over thirty. Since I fitted all these categories I had no further trouble with the Army. But all those remaining in my Army group were sent to the Mexican border to chase Pancho Villa. Many were eventually sent back home, but a lot of the younger ones went on to Europe with the Regular Army. I did not look forward to being shipped back to Europe, especially playing soldier there. To put it mildly, I was greatly relieved to be back with Westinghouse. Of course, Charles Jr. and Martha would have liked nothing better than to join up themselves. Charles, who loved pickles, wanted to be the pickle manufacturer for the entire army, and Martha wanted to be a nurse, or join the equivalent of today's WACs.

As soon as I returned to the United States in 1914, I started again to complete a mechanical engineering course. I always liked home study. While I had practically all the subjects in engineering, it took almost four years of night study to complete the courses because I worked nights in the factory for several years. I had little time to write out the required les-



My midnight oil-burning enabled me to complete my home study courses.



A mechanical-engineering diploma, the product of night study, was awarded in 1918.

sons. Hundreds of pages of writing were required, with sketches and drawings in the thirty-five subjects. Early in 1918 I finally completed the course—given by the International Correspondence Schools—and received a diploma in mechanical engineering. I really did not need this additional course but I always figured you can never know enough. The



In 1917 I was granted membership in the American Society of Mechanical Engineers.

more you know the better off you are and the better your chances in life are. Experience is always a good investment. I was proud to receive this diploma and felt that it was worth working for.

1 1

Later in the year, our family had a taste of the influenza epidemic which took thousands of lives throughout the country. Both Frieda and Martha were dangerously ill, but fortunately they both pulled through.

When finally the dust of war had cleared, making travel possible, and the Eislars were all healthy again, my wife lost no time in leaving for Budapest to see her mother. Along with her went Charles, then five, and Martha, three. Frieda wired me that Charles missed many of the things he was used to in the States, like shredded wheat and bananas. I sent whatever I could to him. Frieda was ready to stay for

years with her mother, and I wanted her to stay until the homesickness had worn off so I could pursue my work in peace and plan my future.

While they were in Budapest I received a letter from my grandmother complaining bitterly about Charles' upbringing. It seems when she extended her hand to him he slapped it instead of kissing it. I wrote to her, explaining that it is not customary to kiss hands in the United States and she should forgive the little fellow for not knowing better. I wrote to the other relatives explaining the situation; it was a great surprise to all the old aunts in Hungary.

After six months Frieda came back to Bloomfield. She had had enough of Hungary; conditions had changed over there and she was completely "cured."

Both children had forgotten their English completely and spoke only German. When I greeted them at the pier, they were dressed like Tyrolian mountain climbers. Charles had a feather in his hat and a knapsack on his back. I asked him in English how he was, but not a sound—he did not know what I was saying. Finally he told me in German that he would never go over there again because they had no ice cream, no bananas, no shredded wheat. Little Martha also was glad to be home again. She said to me in German, "Daddy, I will not leave you any more; I will always stay with you. I missed you very much and I cried for you every day and night."

But for Frieda, this feeling only lasted about a year, and then the same cry started again, about having nobody, being lonesome for her mother, etc. I kept telling her to have patience—that a family is not built up overnight. (After forty-four years she has stopped complaining. In addition to her four children, she now has twelve grandchildren—a total of twenty-two in the Eisler clan. There is no more feeling of lonesomeness; there is no time now for complaints.)

In 1916 I had bought a new four-door Ford sedan. It cost \$360. Four years later I sold it for \$340, which was the down payment on a new Dodge touring car. Frieda, Charles Jr. and Martha had loads of fun going to the shore or out in the country on Sundays.

11. *THE BIG STEP*

IN 1919, after five and a half years with Westinghouse, I resigned as chief engineer of the equipment division. My supervisor warned me that I was making the biggest mistake in my life—I had a responsible position, was well liked and highly respected by everyone, and he implied that I was slated for an upward move. But I had been offered a position with a corporation in Brooklyn, with double the pay I was getting at Westinghouse, and I had decided to accept this offer, which included a sizable cash bonus and a contract.

The new company had made leggings for soldiers during the war, and now they wanted to convert to making electric lamps. I had had plenty of time to think over this decision—the company had sent their representative to my home in Bloomfield three or four times. At first I hadn't been able to understand how a company making leggings could make incandescent lamps. I asked him what his company knew about electric lamps, being tailors of canvas leggings. The representative said that no one in the organization had the slightest idea how electric lamps and machines were made, and that was why they wanted me. I couldn't let such an offer of trust and responsibility go, and I accepted.

My supervisor at Westinghouse predicted that the new company "would not last long because Westinghouse would put them out of business on patent infringements, since we, the cartel, own all patents." He said I would be out of a job, and he suggested again that I think it over before taking the step. "Don't you know that we own all patents on every operation and a new company doesn't have a chance? However, if it does not work out, come back and see me." But I never came back to "see" anyone.

Westinghouse wanted to know if I intended to take any

of my draftsmen with me. Desiring to leave on friendly terms, I told them I would not take any men. Nevertheless everyone in the engineering department was told that "under no conditions were they to associate with Eisler" and anyone seen with me thereafter would be discharged. Many of the men I had known at Westinghouse were of fine caliber and I would have liked to keep up friendship with them, but doing so would have jeopardized their jobs, so I did not encourage it. For thirty-five years I have not talked to anyone employed there.

When I left, there were over seventy-five machines of various kinds in use there, all designed by me in whole or in part. Yet there had been very little personal or financial recognition forthcoming to me, the inventor.

I had been to Brooklyn to see the plant and meet the "boss," Max Ettinger, an ambitious man with big ideas. The plant occupied about 20,000 feet of floor space in the Bush Terminal Building, with five hundred sewing machines sitting idle. The new company was to be called Save Electric Corp. With this large factory, cash assets of about half a million dollars and plenty of enthusiasm, Max Ettinger was looking for a business that would be steady, had good prospects for long-range growth and was a basic necessity in the economy of the country. One product that met such requirements was the incandescent electric lamp.

Ettinger did not know that the electric lamp industry was a monopoly dominated by General Electric. The monopolistic tenacles of GE became very apparent to him, however, when he found that machines for the manufacture of light bulbs and parts such as bases, lead-in wires and tungsten filament wire were not available to anyone unless the concern was a GE licensee. Taking the bull by the horns, Mr. Ettinger approached GE for a license. He was informed that since 1915 GE was no longer issuing any licenses, and that if he persisted in going into the manufacture of electric lamps the company would bring suit under their huge patent pool, which covered all phases of electric light bulbs.

Despite the warning, the rugged individualist Max Ettinger decided to go ahead. He formed Save Electric Corp. and it

soon had a nucleus of experienced personnel, including myself. As chief engineer of the equipment division of Westinghouse, I already had quite a name as a machine inventor and designer. I was hired to design and install Ettinger's lamp-making machinery.

My first job with Save Electric as equipment-engineering superintendent was to clear out the five hundred sewing machines and all the rest of the old legging equipment. Starting from scratch, I then installed ten drawing boards and hired ten draftsmen-engineers to plan the plant layout. I designed every machine required for the production of incandescent lamps, taking this opportunity to make many new improvements on these machines. In six months all was ready; Save Electric was now the most modern, best equipped independent lamp factory in the country.

Sources of lamp parts were secured, in many cases from Europe. Arrangements were made with P. R. Mallory Co. to manufacture our tungsten filament wire. The enormity of starting a lamp plant from scratch with a paucity of available know-how required the expenditure of large sums of money and manpower.

Numerous patent applications were filed covering the various operations of lamps. One of the most important of these, which resulted in a patent, was a method for inside-frosting which did not materially weaken the glass envelope and was an improvement over the outside-frosted bulbs that were rough in appearance and dirt-catchers.

The introduction on the market of Save Lamps was successful when distribution was obtained through channels not then used by General Electric and its licensees. The status of the so-called independents in those days was comparable to that of bootleggers of the Prohibition era, and they were called just that by the electrical trade. The manufacture of independent lamps was usually conducted in a clandestine manner, but Save never operated this way. It held itself out as a legitimate manufacturer operating under its own patents and went so far as to indemnify its customers against patent infringement suits, which was General Electric's principal method of controlling its existing and prospective customers.

Save Electric had an agreement with its suppliers as well that it would defend any suits brought against them by G.E.

In 1920 GE filed a series of suits against Save Electric and also against its principal supplier of tungsten filament wire, the Mallory Co. This was the beginning of a litigation that has lasted some thirty-eight years, and there is no indication that the end is in sight. (I understand the suit is expected to celebrate its Golden Jubilee.)

Modern lamp-making machinery had up till then been exclusively the property of the trusts and cartels; it was not to be had for any price. I opened the field for this industry by making lamp-making machines available. Since the machine shop at Save Electric was too small to build all the new machines that I designed, we gave them out to other machine-builders. Almost immediately the shops that built machines for Save Electric started making them for other companies—all from Eisler drawings. There was a rush for Eisler machines from every part of the country, as well as from abroad. It did not take long for the world to find out that I was making the kind of lamp machine that heretofore could be made only by the cartel, and offers came to me from everywhere. This type of machinery was wanted.

Within nine months Max's Save Electric, making about 25,000 lamps a day, became the largest independent lamp manufacturer in the country. Quite an accomplishment. What happened next was even more of an "accomplishment." One day Max told me not to come in that Sunday—a practice I had been following for several months in order to speed up the work on the newly finished plant. He said that a certain "man" was coming to look over the plant and he didn't want to see me. The "man," it turned out, was Charles Burroughs, vice-president of General Electric.

By now, of course, the cartel had heard about the Eisler designs, and it took action quickly. Save Electric Co. had hardly opened its doors—it was operating only a few months—when General Electric offered to buy us out, and the sale was made less than one year after the plant was started. It was my understanding that GE paid Save Electric one million dollars to quit the incandescent lamp manufacturing

business. All Eisler-designed machines were removed and the business was discontinued. Although I had worked day and night for almost a year, although I had seen my family only about a dozen times in that period (commuting took two hours each way from Bloomfield to Brooklyn), although I put up the new plant in only six months, and although I was the one who designed all the equipment which sparked the profitable sale, for all these "extras" I received not one cent of additional compensation from the Save Electric boss.



Above: Max Ettinger in a happy pose in 1920. *Below:* Ettinger and Eisler in 1948.

I thought about this for a while. I figured, if I can make these machines so rapidly for others and they can sell out so quickly for such a large profit, why not do it for myself? Whereupon, with the closing of Save Electric Co., I proceeded with immediate plans to start my own company, the Eisler Engineering Company, in Newark.

The first thing I did was to purchase a small machine shop in Kirk Alley. It was in the same building in which Edison started, and the original owner's son, Mr. Simpson, told me

Above: Breaking ground on 13th Street, 1920. *Below:* The Eisler Engineering Company in Newark as it looked in April 1929. Four hundred and fifty employees line the sidewalk.

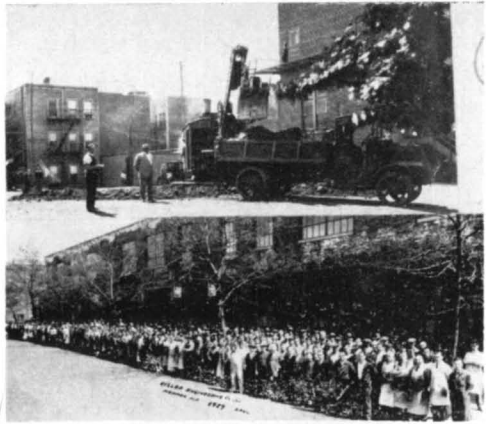

“Where it all started”—my first machine shop at 15 Kirk Place, Newark, opened June 13, 1920.

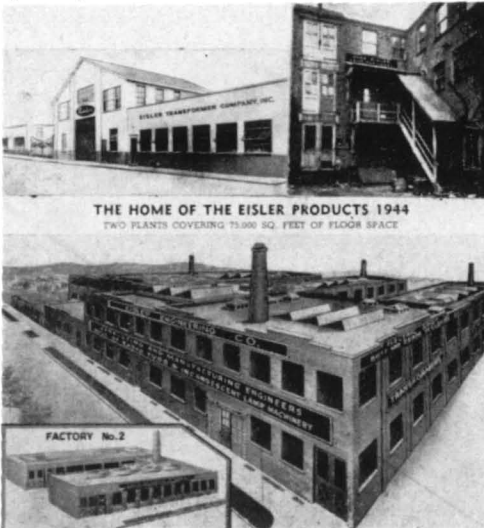

Above: (left) The Eisler Transformer Company at Dover, New Jersey; *(right)* The sign here read “Chas. Eisler Lamp Machinery, Kirk Place” in 1920. *Below:* The 1944 plants, covering 75,000 square feet in two buildings, in Newark.

that I too would be very successful and prosperous. In fact, he told me not to pay him the thirty dollars monthly rental for at least six months, and that I should use the money to get started. This was in 1920 and exactly twelve months later, when I moved to larger quarters, I paid him for eighteen months for being so kind to me.

Working day and night, I quickly redesigned all my machines, adding new types and patenting everything. I made my own drawings and, in most cases, my own patterns. As soon as I was ready, I had the machines built by the Eagle Tool Co., a next-door neighbor. Soon the machine shop was fully equipped.

When all was in readiness, I opened the doors of my modest plant. I announced in the trade papers that I could supply incandescent lamp-making machinery. The results were instantaneous. The name Eisler Engineering Company went like lightning all over the world. Orders for Eisler machines poured in from everywhere, and before the year was up my little plant in Kirk Alley was too small for my operations. I immediately built a larger factory on South 13th Street, and soon that one was also too small. Orders kept coming from all over the country and from Europe, and I was traveling at high speed.

But the picture was not all rosy: patent litigations were soon started against me.

12. *AT GRIPS WITH THE OCTOPUS*

I HAD hardly printed and distributed my first catalog and sold a few machines when I too was sued by the cartel, made up of Westinghouse, GE and RCA and including all members of the trust in Germany, England, France, Italy and Hungary.

It seems that the "big three" had gotten wind of the fact that the Eisler Engineering Company was designing and building machinery in direct competition with them. While I was with Save Electric, we used an outside machine shop, the Hoffman Co., to handle most of the machine manufacturing; it built machines from Eisler drawings. Since every lamp machine was designed on the premises of Save, Hoffman naturally was under contract not to sell these machines to anyone else. But many independent companies, and even the members of the cartel, would see these machines when their representatives happened to visit Hoffman. And they all wanted them, especially the independents, since the labor-saving factor was of tremendous significance in making substantial profits for these little operators. The temptation was too great for Hoffman—contract or not, license or no license, he sold machines to everybody. It was just about the time I opened my shop that General Electric found out Hoffman was selling machines to nonlicensed lamp manufacturers; they acted quickly. Fearing competition, they gave Hoffman a license—this was about 1922—and he agreed to make machines only for the cartel and its licensed members. So for a while Hoffman stopped taking orders from outsiders, at the time the Eisler Engineering Company had to double and triple its capacity, since business was now headed my way. In fact, only a year after Hoffman signed the contract limiting his sales, the greatest boom in the history of the world—or so it seemed to me—started in the lamp machine business.

The machines were in phenomenal demand—not merely to make lamps, but to make radio tubes. Of course the lamp business was a steady one, but the real growth, from 1924 to 1928, was in this radio tube field. It was a world-wide boom. When Hoffman saw the start of this rush, and realized all the business he was losing because of his contract with GE, he returned the license and proceeded on his own. He now was able to sell not only to many old licensed customers, but to the new independent group as well. He still had some Eisler drawings, which he simply copied, and sold machines made from Eisler drawings to everyone.

When this happened, GE decided to clamp down. However, they chose to sue Eisler instead of Hoffman, since they evidently saw more danger in Eisler. If they had sued Hoffman, they would have been sure winners, because Hoffman not only did not have any lamp machine patents or even drawings of his own, but he had been selling Eisler machinery without authorization. The agreement with Save, under which he made machinery from Eisler drawings supplied by Save, did not give him the right to duplicate these machines for others. And since he had no legal right to these drawings his case would have been disposed of very quickly. But this was not to be. The cartel aimed its heavy artillery at me.

The cartel's large staff of lawyers from well-known firms did their best. Every patent in the field was introduced in court. Despite the fact that I had patents of my own, I was sued on practically everything that I had made. Everything humanly possible was done to put me out of business. The trust—the cartel—was determined to get me out of the way, to stop me from building machines for other manufacturers who were not in the cartel. They figured, every machine Eisler sells is a competitor. But the long litigation failed to accomplish their purpose, for I could prove prior art since I had made most of the machines in Hungary long before I had worked at Westinghouse.

In charging patent infringement and contributory infringement in the case of many of the automatic machines, it seems to me that these powerful corporations acted hastily and were ill-advised. They could not have spent much time consider-

ing the merits of the case or they never would have gone through with it. I had made these inventions years before I started working for Westinghouse, and could prove it, and their attempt to prove otherwise was indeed one of the stupidest pieces of judgment ever shown by otherwise intelligent people. The feeling that they "couldn't lose" was an understandable one, since the cartel had for years been eliminating its competition in just this way. GE had brought twenty-three infringement suits under the Pipkin patent alone. Of course, most of the time any manufacturer sued by them would "roll over and die"—he didn't have a chance; even if he did he couldn't afford the expense of a long litigation. As I tried to explain to Mr. Wilson and Mr. Swope of GE and to Mr. Sarnoff of RCA, there was no basis here for a court fight, since I had legitimately invented these machines previously. But it was no use; the harder I argued the more determined was the cartel to "get" me, and their huge legal staff proceeded to press the suit and take me to court.

Aside from many drawings and machines which were traced to my days in the Ujpest Co. in Hungary where most of the designs were originated, my strongest piece of evidence was an article I had written with my own sketches in 1916—five years before—for the magazine *Machinery*. It was on tungsten lamp manufacture and was based on the knowledge I had picked up in Hungary. In fact, the article caused quite a stir on publication because at the time I wrote it I worked for Westinghouse. I was told by my superiors there that I had no right to publish any articles on the manufacturing method used in incandescent lamps; the cartel felt that such information should be restricted to the cartel and its licensed groups. I was politely told that in the future I must submit all contemplated articles to the management for approval. Of course it was not my intention to reveal any American manufacturing methods; the article did not reveal information which the cartel had carefully guarded from outsiders. But I did want to disclose that Hungary also made incandescent lamps and I wanted to demonstrate Hungarian methods. The article was even subtitled "Processes Used by the United Incandescent Lamp Co., Budapest, Hungary."

At any rate, there were no more articles, but the existence of this one in 1916 was indisputable evidence that I had been previously working with the same machinery which was claimed to be "infringements."*

The cartel figured that it would have Eisler closed up in three months, but it did not work out that way in the United States where we have fine courts and fair judges and enjoy the democratic way of doing things.

Legal proceedings take time, and this case was no exception. It took several years of litigation before the courts found that there was no reason to close up the Eisler Engineering Company; during those years I continued to ship my machines all over the United States and to many European countries. Business literally boomed. And now after thirty-nine years the company is still making lamp and radio tube machinery, and going strong.

Instead of suing me, Westinghouse and GE would have been better off if they supplied my little plant with their own work. At that time they were giving out a million dollars worth of business to small shops in Newark. Giving me that work or part of it would have kept me from building machines for other companies.



Above: The Eisler plant in 1924. Left: The drafting and engineering department was established in 1923.

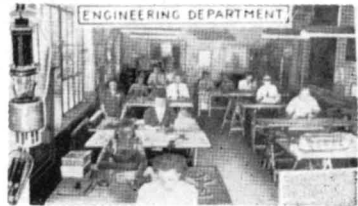

In 1924, just four years after I purchased that little machine shop, my new plant needed an addition. With the

*See APPENDIX for a reproduction of my *Machinery* article.

extra machine tools being used, I now had a staff of about two hundred men. With the radio tubes in an ever-increasing demand business continued to boom. And with the favorable patent decisions, especially on the tipless method, the electric lamp business gained new life. Before 1924 was over, the plant had doubled in both physical size and labor supply, which was now 450 men.

By 1929 the radio tube industry had reached the peak of its phenomenal growth. I had to have outside help from other machine shops to keep up with the demand. Everybody who had been making lamps had begun making radio tubes, and throughout the world this activity spiraled upward. But as sudden and substantial as was the growth, the letdown after the 1929-30 crash was even more sudden. I cannot quote figures of the other lamp manufacturers—75 per cent of whom went out of business—but production in my plant dwindled rapidly until I had a staff of only fifteen men. And in all the years since, production has never quite reached the point it achieved in mid-1929. Although the newest Eisler plant, built in 1940, occupies about 70,000 square feet of floor space and is equipped with the most modern American and European machine tools, we employ about two hundred people.

Though the cartel lost all its suits against me, it may not have been so good for me. Perhaps it would have been better if I lost all the patent suits. Let me explain: The three largest companies—GE, Westinghouse, RCA—were bitterly disappointed when the courts did not find me guilty of infringement of at least one of the patents in question. So bitter was the reaction and so determined were they to stop me from supplying any more equipment to the lamp-makers that they got together and decided on a procedure similar to blackballing. The management of Westinghouse gave strict orders to their engineers and buyers that anyone seen in the company of Eisler, either on business or for private reasons, was forfeiting his position. Under no condition could anyone place an order for anything with me. Since I had given them such a "raw deal" this company has not permitted anyone to so much as ask for a quotation in the last thirty years. The only men who ever came to see me were those who

had already lost their positions, and it was from them that I picked up the information mentioned here. The cartel has given between thirty and fifty million dollars of business to outsiders in these thirty years, and possibly I lost more by winning the suits considering that all this business went to others—not a nickel of it to me.

During those thirty years a man came to my office and told me he wanted to talk to me about the machines he had heard of, which give such good results in the independent factories but were not used in the cartel. When I found out he was from my old company, I said to him, "Please don't talk to me, because if someone should find out you are here you can lose your position. I would not want this to happen to you."

He replied, "Mr. Eisler, we all know about the men who hated you and gave these orders. They have all died, and we have nothing to fear any more. You have no more enemies left. We now can buy equipment where we feel we can get the best for our purposes."

And with that he walked out of my office and I have not seen him since. I did not even get his name, nor what position he held, but I welcomed the information. Of course, I was glad to learn that I had no more enemies, but not that they had passed away. I would have been happier about it if my so-called enemies could have called on me in person and told me what fools they were, and that it was all a big mistake. They probably would have benefited from talking to me occasionally over those thirty years.

In the summer of 1924, in the midst of these litigations, I started organizing a group of independent manufacturers—those unfortunate victims of the cartel's pressuring tactics—whose objectives were similar to mine. They too were threatened by the patent suits, since many of them used Eisler machines, and most of them were on the brink of being closed up. I felt that unless we banded together—organized—we might all be out of business shortly. I started holding meetings every Saturday. At the very first meeting, attended by about thirty manufacturers, I received a list of all lamp-makers who had been closed up or "bought up" by the cartel.

There were about twenty-five names on the list. Those companies which were still alive were even more determined to stay that way. We felt that our voices might be heard some day.

Every meeting was more crowded than the one before until after five months my office space was too small; we moved to a hall where the meetings have been held for more than thirty years.

All the members contributed large sums. We elected a president and a secretary and hired very able counsel—the best that money could buy. The association spent \$100,000 on legal advice during the first ten years of its existence. After the group engaged its counsel, the cartel was unable to close any more lamp companies on account of “infringement.” The little man was not hiding any longer; he did not have a dark curtain on his door. He worked openly. In fact, the shoe was now on the other foot; in many cases the little men received large refunds from the cartel. The most memorable incident in this respect is the unexpected refund by Corning Glass Co. who, together with the cartel, had overcharged the independents in the past. Having proved this in court, the little fellows were thus entitled to thousands of dollars in rebates. And as an extra bonus in the course of settling the litigation, General Electric agreed to give the independents certain machinery blueprints which had heretofore been restricted to members of the cartel.

The first court action took place in Newark. I had as my counsel a very able and distinguished patent attorney, Richard Eyre, president of the Patent Lawyers Bar Association. Judge Bodine did not waste much time in declaring “no cause for action,” meaning no infringement. But this was merely the first round. The cartel then proceeded to add several more machines to their suit, and appealed the decision immediately, taking the case to the United States District Court in Trenton. It was there in the state capital that the real fight took place. There were three judges—Wooley, Davis and Buffington—and half a dozen cartel lawyers haunting the place.

Even after thirty years I can still remember some of the

highlights of the trial. I received the permission of the court to demonstrate my own machinery. There in court I made several stem heads on the tipless machine I had invented. The judges were quite impressed. But the debates went on for four days. I had proof in black and white that I had designed these machines more than ten years before in Hungary, but the cartel still claimed infringement. The General Electric attorney in his cutaway and striped pants, with pincers on his nose (I can still see him), called to me, shouting loudly, "Your honors, may it please the court . . ." waving his finger in front of my nose and turning to the three learned old judges on the bench, then glaring back at me, and then back at the bench, shouting, "This man Eisler is the biggest infringer in the country! Everything Eisler makes infringes on our patents."

During a recess I told my attorney that if the GE lawyer kept on pointing at my nose I'd poke him in his nose in return. My lawyer Eyre, a very quiet, dignified, correct gentleman, told me: "Eisler, keep your Hungarian head cool and say nothing. The court will recognize his shouting but not for his own good."

And when it came time for the verdict, again it was "no infringement; no novelty in the cartel's machines."* And not only was Eisler's patent sustained, but the cartel's patent was voided. When four of the patents had been handled in this manner after several years, the cartel withdrew the suits for the other four. They were whipped, and they knew it. It was a bitter pill for them to swallow, especially since it liberated all the independent lamp and radio tube manufacturers. This victory in the United States was reflected in many European countries, especially in England, France, Hungary, Germany, Italy and all other places where the cartel had been powerful before the Eisler litigation.

Incidentally, all the "little fellows," including Eisler, made approximately two per cent of the lamps at the time of the suit. The cartel had gone to all this trouble to eliminate just

* *General Electric Company v. Eisler Engineering Company*, 20 F (2d.) 33 (C.C.A., 1927).

two per cent of the business—which was the extent of the competition. Here was an ironic example of bloated power, and an ending which saw the underdog sitting on top of the bully.

When the last appeal had been rejected and the final suit had been defeated, it was already 1928—almost five years of litigation. I then placed the following notice in a trade journal:

It is my opinion that the advice of only one or two men was at the bottom of this litigation. I believe that one man at Westinghouse was the real instigator of this suit; I spoke to him several times during those early years and he gave me the impression that he was personally going to follow through with action on the tipless stem, tungsten wire and copper-clad wire “infringements.” And he also took credit for the closing of Save Electric. He obviously swung a lot of weight with GE as well.

After I was judged “in the right” on all suits, the *Newark News* referred to me as a “trust buster.” Of course I did not seek notoriety; I would much rather have remained on good terms with the cartel than spend \$45,000 of my own money fighting an unnecessary legal battle.

Not one of the lamp manufacturers ever contributed so much as a nickel to the expenses of carrying this case through the courts. I had to be satisfied with the increased business which resulted from the decision to help make up for the financial burden I had carried. In fact, some of the independents even forgot about Eisler completely and gave their business to others. But for the most part, with the increase in production I got more and more business.

The growth of the radio tube industry was indeed one of the fastest in the history of American business, and I had a major share of it. One thing all the independents did—on every one of their cartons they had printed: THESE TIPLESS LAMPS ARE MADE UNDER EISLER PATENT No. 1,637,989. They all agreed that Eisler had done a good piece of work for them. But most independent lamp-makers soon forgot the sacrifices I made to save the independent lamp and radio tube industry.

It was directly as a result of my trial, which indicated how the little men were eliminated, that the law began to take more interest in the goings-on of the cartel. After that there was a change in the attitude of the courts—no more leniency to the cartels. In fact, much of the legislation designed to break up monopolies was begun shortly after the Eisler case was concluded. This case has brought out in the light how the cartel tried to perpetuate its strangle hold on the little fellow by adding a little gadget to its patent so as to make suits possible.

The patent litigation is well described in the book *The Electric-Lamp Industry*, by Arthur A. Bright, Jr. This volume, subtitled *Technological Change and Economic Development from 1800 to 1947*, was published in 1949 as a report on a study of the economic development of the electric-lamp industry undertaken at the Massachusetts Institute of Technology, the second in a series of studies on the economics of innovation. I quote from page 274:

The Mitchell and White tipless-lamp patent had a somewhat simpler, though longer, court record. The patent, which covered a particular method of constructing tipless lamps, was initially infringed by the unlicensed companies. After a number of suits had been brought under it and the case against the Save Electric Corp. of Toledo, Ohio, had been pushed through successfully by General Electric, the independents switched to the use of the old Jaeger technique, the patent for which had expired in 1920. The Jaeger method was more costly, but it permitted the independents to make tipless lamps freely without legal complications. Although the Mitchell and White patent for the General Electric construction was again held valid in a prosecution against the Eisler Engineering Company in 1927, it was held not infringed by lamps made by the independent manufacturers with the Jaeger technique. At the same time a companion Mitchell and White patent covering the machine for producing stems for the General Electric tipless lamp was declared invalid for want of invention.

There is further reference to me on page 276:

An important factor in the collective rise of the unlicensed lamp producers during the thirties was their organization of the Incandescent Lamp Manufacturers' Association in June, 1933. It was strongly encouraged and supported by Charles Eisler of the Eisler Engineering Company and by other outside suppliers of lamp parts and equipment. The suppliers naturally wished to keep the unlicensed manufacturers in business to provide a continuing and growing market for their own products.

The Association has advanced the common interests of the unlicensed producers through the exchange of information, coordination of activities, and by a variety of other ways. One of its principal functions has been in connection with patent litigation. Prior to 1933 the individual small producers could not afford to fight General Electric on patents. With the organization of the Association and the expansion of their production, they pooled their resources to hire outstanding counsel in the defense of infringement suits initiated by General Electric against any one of them. Each independent company had a similar interest and stake in the outcome, and their joint action permitted them to afford defenses which would have been too expensive for individual companies.

What Bright did not mention, or perhaps did not know, was that I actually organized the Incandescent Lamp Manufacturers' Association as early as 1924.

A significant issue in this patent affair was that tipless lamps had been on the market for many years *before* the cartel's tipless-lamp patents were on record—tipless lamps had been manufactured since 1878—and the cartel's patent was issued in 1918 or thereabouts. Yet the cartel was so powerful it was able to prevent the independent lamp manufacturers from making tipless lamps. It seems that not one of the independents looked up the prior art, or if they did there was nothing they could do about it.

The lamps of 1880 were not bad—Edison had sold a lot of them. Their stems were pressed with hand tweezers and hand pliers, and so stem-pressing was really not new in 1924. Mitchell and White, who merely added an air jet, patented this procedure for the cartel. On the basis of this air jet the

cartel would have closed up the independent lamp industry in the United States and all over the world. The court established that "air" cannot be patented—and thus one of the cartel patents was voided again.

Other contributory infringements were claimed because my machines used copper-clad wire or tungsten wire. But again the cartel was defeated when the court ruled "no novelty" in the case of these materials.

The carbon lamps which appeared on the market in 1878 were actually the breeding ground for the eventual tungsten lamps, which were considered the "offspring." The manufacturers, engineers and scientists making carbon lamps gained experience and particular knowledge which was of the greatest benefit in the invention of the tungsten lamp. Many of the operations are similar—it was a case of more automation for greater production rather than any great difference in approach. And in turn, in the manufacture of tungsten lamps, additional knowledge was gained for the next step: the making of radio tubes. While the latter required a great deal of scientific and engineering knowledge—more than was necessary for the lamps made previously—nevertheless most radio tube manufacturers got off to very good starts, because prior lamp equipment and engineering skill was available to them. In fact, the main problem—if you could call it that—was the matter of improving the equipment for the new process. Stem, exhaust and sealing were practically the same as in the general lamp business. Additional scientific knowledge was needed for certain elements in radio tubes which did not exist in ordinary lamps. But in the case of television tubes very little additional knowledge was required. While television machinery requires a great deal of large equipment, the production methods are not as complicated as those in making carbon lamps during their heyday. Of course television lamps again required new scientific knowledge since the tubes are more complicated, but from the point of view of production the easiest step in the progression is the last one.

Our scientists have made such tremendous gains in the production of radio tubes and then television tubes that, from my observation, the American television tube today ranks as the best anywhere. There is no question that the future has many new things in store for the scientist and the equipment manufacturers. I predict that television tubes, which are now anywhere from 24 inches to 36 inches in diameter, will eventually be replaced by tubes 2 inches in diameter—to be manufactured for 10 per cent of the cost of the present large tubes. Lamp and radio tubes are almost completely automatically made—all parts are now being fed through necessary hopper feeds and transferring devices, but eventually they will be made without being touched by the human hand. With the present high labor cost there is an imperative need for such automatic machines. Automation is a must for the American manufacturer to stay in business. Foreign competition is too keen, and the only way the American manufacturer will be able to compete in the foreign market is by automation.

13. IN THE PRESS

THE REACTION of the press and trade journals throughout the country to this historical litigation is significant, and in this chapter I include selected quotations and excerpts relating to the issues involved in the case.

First is the advertisement I ran in the January 1929 issue of *Radio Retailer & Jobber*, following the decision:

RADIO TUBE MANUFACTURERS!

The Eisler Engineering Company, of Newark, New Jersey, manufacturers of radio tube and incandescent lamp machinery, desires to call to the attention of the radio trade the decision rendered, December 21, 1928, by Judge Bodine, of the United States District Court, District of New Jersey, in the action brought by the General Electric Company against Charles Eisler and the Eisler Engineering Company, Incorporated.

In this decision Judge Bodine holds that the sealing-in operation employed on the machines, manufactured by Charles Eisler and the Eisler Engineering Company, Inc., does not infringe on the General Electric patents.

As a result of this litigation the equipment manufactured by Charles Eisler and the Eisler Engineering Company, Inc., is judicially declared not to infringe the existing patents of the General Electric Company. Therefore, Eisler machines may be employed without any fear of infringement in the future.

This is the fourth decisive victory that has emancipated radio tube and lamp manufacturers from the yoke that otherwise has restrained them from carrying on their business. The four suits which the Eisler Engineering Company has fought and won, in the interests of the radio tube manufacturers, embrace the following processes or products:

1. Tipless—Stem-Making
2. Tipless Method
3. Inserting—Tipless
4. Sealing-in—Tipless

We take this opportunity of thanking the radio tube manufacturers for assistance in helping us to secure this sweeping victory.

A 1925 report in *Radio Guide* was headlined EISLER'S RIGHT TO MAKE ITS TUBE MACHINERY UPHELD, and follows:

A sweeping decision, upholding the right of the Eisler Engineering Company, Inc., of Newark, New Jersey, to continue making machinery for the manufacture of an extensive line of tipless radio tubes, has recently been rendered by Judge Bodine, in the United States District Court, in Trenton, New Jersey, despite the efforts of the General Electric Company to stop the production by that corporation of machines for this purpose on the ground that they infringed the so-called Mitchell and White patents.

These Mitchell and White patents, designated as U.S. Patents Nos. 1,423,956 and 1,423,957, and popularly known as the tipless-tube patents, set forth certain claims for making tipless vacuum tubes for use in radio. They were issued only two years ago and assigned to the General Electric Company, which has since then been seeking to enjoin numerous manufacturers of tubes with rounded ends from making such products on the ground that they constituted infringements of these patents' claims.

The Eisler Engineering Company, Inc., which makes the machinery for more than 90 per cent of the independent radio tube manufacturers in addition to manufacturing machinery for making incandescent lamps, has been making machines for this purpose for many years. Charles Eisler, president of this corporation, who was also joined as a defendant in the suit instituted by the General Electric Company, has shown that he had been manufacturing these machines for more than fifteen years.

The General Electric Company sought in its suit against the Eisler Engineering Company to show (1) contributory infringement on tipless stems and tipless stem machines

over a period of several years; (2) infringement of the Mitchell and White patents on the score of tipless stems; (3) infringement of these patents on the score of making stem machines; and (4) damages caused the holder of these patents during the last few years.

It was shown by the Eisler Engineering Company that the process of making tipless tubes with the machines manufactured by it is different from the process outlined in the Mitchell and White patents and that the machines which it produces are of different design and operation; further that Charles Eisler had been making such machines for fifteen years or more, whereas the Mitchell and White Patents were issued only two years ago.

Judge Bodine ruled that the Mitchell and White patents had not been infringed and that the owners of these patents are not permitted to stop the manufacture of these machines for the making of tubes exhausted through the stems. In his opinion, this jurist stated that the Eisler Engineering Co. has a right to manufacture these machines and, in so doing, does not infringe the patents in question.

This decision in favor of the Eisler Engineering Company, on the score of tipless tube making machinery, follows the general lines of a decision of the United States District Court for the District of Rhode Island, at Providence, in May 1925, in which the General Electric Company had sought to enjoin the C.E. Manufacturing Company, of Providence, makers of CeCo tubes, and several distributing concerns, including the Providence Distributing Company, on the ground of alleged infringement of the Mitchell and White patents.

It was shown in this case that the Mitchell and White patents set forth claims on the process of manufacturing tipless tubes, the machine for making them and the product itself. The process outlined in these claims calls for the making of the stem separately from the bulb and for slipping the bulb on after the stem is made; then in exhausting the air from the tube through the stem. The C.E. Manufacturing Company showed, however, that its process of manufacturing tipless tubes, for which it had made application for patent rights, was entirely different from that set forth in the Mitchell and White claims and the

court thereupon declined to grant the preliminary injunction asked for by the General Electric.

Subtitled "A Thrilling Story About the Battles Over the Evasion of Radio Tube Patents," Volney G. Mathison's entertaining and descriptive article, "The Million-Dollar Bend," appeared in the February 1926 issue of *Radio*:

Three men, an American, an Englishman and a Hungarian, sat about a plain oak table. Wind-driven rain beat against the small glass panes of the fabricated steel windows of the cold, bare big room in which they sat; and through these windows was presented a cheerless, drizzling view of a section of the great grimy city of Newark.

The faces of the American and of the Englishman were troubled. Indeed, they looked sick. One might have thought they had indigestion, or toothache.

"There are so many millions of dollars imperiled by this injunction that I don't like to estimate them," the American was saying. "My vacuum-tube factory and business conservatively is worth \$500,000 to me; and that of Archie here is worth quite as much as that to him. And we are only the spokesmen of an association of thirty-five tube manufacturers. Taken collectively, we are the makers of half the tubes that are being produced today. Yes, we're all in the same cage; and the big one-eyed ogre who is going to eat us is the Wide-World Electric Corporation. That fellow, the emperor of all the tube makers, has secured exclusive control of the patents on the machines we all use in making tube-stems. He has served court injunctions on us, all and severally, not only in America, but in Great Britain, France and Germany, that restrain us from using these stem-making machines."

"And," put in the Englishman, "if we cawn't use our machines, we really cawn't make the infernal things, don't you know—"

"Half the tube production of the world is jeopardized through these injunctions," continued the American. "If our powerful competitor can put us out of business, it not only means a loss of millions to us tube men, but it means, in the course of time, possibly many more millions to the users of radio tubes."

"Really," again put in the Englishman, earnestly, "if we cawn't use our machines, we cawn't well make the infernal things, don't you know?"

As the two tube men told their tale of trouble, the Hungarian listened in thoughtful silence. An extraordinary-looking man he was, broad-faced and thin-lipped, with coal-black hair richly sprinkled with silver.

He was the owner of the plain oak table at which the three men were gathered, of the high, bare, plastered room with the steel-latticed windows, and of the \$1,000,000 factory devoted exclusively to the manufacture of tube-making machinery, which adjoined the plain council-room. Scarcely twenty years ago, this Hungarian had come to America with few more worldly goods than a T-square and a set of drafting instruments—but possessed of a past master's knowledge in the art of mechanical glass-working. Since then, tool by tool, machine by machine, he had acquired this great plant; and his marvelous mechanical genius had expressed itself in the design of hardly fewer than three hundred elaborate machines for use in tungsten-lamp and radio vacuum-tube manufacture. This was the man whom the tube-makers, imperiled by injunctions involving a mechanical glass-working process, had come to for rescue from threatening extermination.

"Gentlemen," said the Hungarian slowly, "there are, as you know, a hundred details to the machine for making the stem of a radio tube. On what exact point are you attacked for infringement of your competitor's patents?"

"It is on the method of putting a small glass pipe or exhausting-tube into the 'crush' or flat part of the glass stem, among the seven sealed-in wires that support the plate, grid and filament. It is a patent on the devices whereby the exhausting-tube, the flare and the mounting-wires for the elements are all molded into the flat stem shape in one operation in the gas flame; while at the same time a jet of air is shot into the little exhausting-tube to blow a hole out through the side of the stem, thus connecting the exhausting-tube with the interior of the bulb that will later go over the stem. If we could get the exhausting-tube out of the 'crush' or flat part of the stem, we'd be all right."

"Why, then," said the Hungarian, "there you have the

key to the solution of the problem. Take the exhausting-tube out of the place where it now is, and put it somewhere else."

The American and the Englishman both laughed, mirthlessly.

"Yes," returned the former. "Columbus made an egg stand on end, but he broke the egg! You are the maker of this equipment for us; and you know what the mechanical difficulties would be in building a high-speed and an economical machine to weld the exhausting-tube in any other position than that which we now use—"

The Hungarian raised his satiny-skinned hand.

"When it is air and it is glass—and when—"

"Yes, we know you can do anything with those two."

"Air and glass, yes," continued the Hungarian. "It is more; it is that I am the top-notch in the cage of the big feller you say is the one-eyed okra, who is starving to eat you. If there is no tube-makers, there is no tube-machine business, no!"

This was true. The Hungarian, with his great plant and his force of skilled employes, was a bigger factor than any dozen tube-makers. The patent-holding corporation had challenged his ingenuity and resourcefulness. They had cast a menacing shadow over his very business existence.

He picked up a sketch-pad from the table.

"Gentleman, I am going to leave you here awhile," he said. "Please remain seated."

With his pad and a pencil, he walked out into his factory, an immense establishment of a thousand marvelous whirring machines—machines that pump vacuums too high to be read on the most delicate of scientific gauges; and machines that automatically perform supremely skillful and difficult tiny wire-and-glass welding operations, with the employment of four gases, electricity and the utmost of mechanical intricacy.

The two tube manufacturers remained in the bare office, slumped in their chairs, one glumly chewing on a big black unlighted cigar, the other contemplating the section of the dripping grimy city revealed outside the steel-sashed windows, and looking as if he would like to kick it.

The Hungarian glass wizard went to that part of his factory where radio tube stem-machines were being con-

structed, a hundred of them at a time. Standing before a completed machine, which was set up on a proving-block, he ordered an attendant of the testing room to put it into operation. Then, as it went round and round, carrying its rotating batteries of hot hissing gas jets that looked like turning reddish-purple flowers, he stood and gazed at it. For a long while he stood there, thoughtfully, sketching a little, but not much.

At length the machine before him ceased to engage his attention. He no longer saw it, even though he looked at it. Instead, he was watching an imaginary delicate glass-welding process, and studying the mechanical action that accomplished it—for it is the power to visualize, to see in the mind a thing complete that does not yet really exist in fact, that constitutes the genius of the inventor.

After he had been absent hardly thirty minutes, the Hungarian returned to the two troubled tube men in the office.

"Gentlemen," he said "I am going to take your order for a non-infringing stem-machine. The price for a machine producing not less than a thousand radio-tube stems an hour will be three thousand dollars; and you must guarantee me an order from yourselves and your associate manufacturers of not fewer than one hundred machines."

The two tube-makers sat up in their chairs and stared at the glass wizard.

"Are you kidding us?" the American demanded.

The Hungarian smiled. "Does \$300,000 sound like kidding?" he returned. "That is the size of the order I am taking today. Place it subject to the provision that the machines will produce non-infringing tube stems as rapidly and cheaply as the present type in use—or no pay."

The American pulled out a fountain pen. "All right," he said promptly. "Give us something to sign—" Abruptly, he drew back. "But the injunctions have already been dropped on us; and this is the middle of the rush season—when do we get delivery?"

"Not this afternoon," replied the Hungarian, with a slight twinkle in his eye. "We'll say in thirty days, counting from today. If sooner, I'll make an extra charge of two hundred dollars for every day less than thirty, for every machine we deliver."

So the two tube-makers placed the \$300,000-order with the Hungarian glass wizard for a hundred machines they had never seen; and which in fact did not yet exist, except in his fertile brain.

"It's just a matter," said the Hungarian, "of putting a little bend in a glass tube."

"By jove, it may be only a little bend, or a bow-knot, or a banana," responded the Englishman. "If it pulls us out of the muck, it's jolly well worth a million. Really you know, if we cawn't—"

"Yes," smiled the Hungarian.

"Then we will call it the million-dollar bend."

The problem was to put a bend near the end of a glass tube 4 inches long and about $\frac{1}{8}$ inch in diameter; to weld this bent end into the inside wall of another glass tube 2 inches long by $\frac{1}{2}$ inch in diameter; and to pierce or blow a connecting hole through the wall of the larger tube. This larger tube would form the stem of a radio vacuum bulb; and the small bent glass tube welded into it would comprise the exhaust connection.

Now, it would not be much of a feat for an expert glass blower to do such a job as this by hand; but the joker in the problem was that this job, which would ordinarily require the close attention for several minutes of a glass-working expert, must be done automatically by machine, at a speed of a thousand or more welds per hour, and at a cost of a fraction of a cent for each operation.

Without going further into detail about the mechanical and glass-working problems involved, or the method of their solution, it will suffice to say that within ten days the Hungarian had designed and built the machine which has made possible the manufacture of a non-infringing radio-tube stem on a cheap, big-production basis. So, briefly, was brought to an early death one of the most powerful patents that ever threatened the radio tube manufacturers of this country with extinction.

The mind of the radio public is muddled on the vacuum-tube patent situation. At one time, you read in the newspapers seemingly well-founded announcements to the effect that "all patents" on radio tubes have expired; and that anyone is now at liberty to manufacture them. Then you turn around a week later and read in the same paper

where "Honkatron and Blunkenham sue Supertink for \$10,000,000 for alleged infringement of radio tube patents," "Radio Gobblers sues Little Boy Blue Tube Co. for \$10,000,000 for alleged infringement of radio tube patents," "Blinkaclink sues Vampavox for \$10,000,000 for alleged infringement of radio tube patents," "Pink Bulbs sues Purple Prong for \$10,000,000 for alleged infringement of radio tube patents"—and then, as if to top it all, along comes a mystical gesticulating Toodle-de-la-Toot from Toulon or Graustark or somewhere, who declares he is the first man in the world who ever lured an electron into captivity and made it jump through a hoop; who owns a wonderful radio patent underlying all the other radio patents in creation; and who is going to sue Honkatron and Blunkenham and Radio Gobblers and Little Boy Blue and Supertink and Blinkaclink and Vampavox and Pink Bulbs and Purple Prong, and forty-three dozen other tube manufacturers, for 675 million billion pesetas for "alleged infringing of radio tube patents." However, he is soon appeased with a good cigar; and then goes gaily back to Graustark without his 675 million billion pesetas for alleged infringing of radio tube patents—to the further mystification of the puzzled and paying public, who wonder what in blazes it's all about, anyway.

It is a fact that there is not, and probably never has been, a business or industry on the face of the earth wherein has been carried on such unscrupulous, such mean, such ruthless pirating and stealing of patents, of trade secrets and of ideas as has occurred in the radio business. Not a coil, not a condenser, not a battery, in fact not even a mere binding post in your set but has been, or still is, the object of a million dollars' or so worth of fierce patent litigation. Even the phone plugs have been yanked from hand to hand for years; and hardly a loudspeaker on the market today but has been squawked over vociferously in a dozen patent suits.

But of all the battles over the patents covering the units in the modern radio receiver, none have been so terrific, so costly and so prolonged, none have been more confusing, various and conflicting, and none have involved such enormous sums of money, as have those which have raged about the radio tube.

There are several reasons for this. The principal one is, however, that the vacuum tube is the most wonderful, the most widely used and the most profitably manufactured single thing in all radio. Then, too, some of the patent-suit massacres and stories of patent-suit massacres dealing with radio tubes seem to have been started that were deliberately intended only for the purpose of throwing a scare into somebody and muddling everybody.

Notwithstanding the often-quoted statement that all tube patents have expired, there are today about 40 unexpired patents covering the modern radio tube. About 30 of these patents are in the hands of one corporation. They involve almost everything about a tube, from the frosting of the trade-mark on the bulb to the color of the hair of the girl who packs it in its box.

Some of the later patents are clever attempts to renew or reinforce other older ones; some are of no use whatever in the making of a tube, and therefore mean nothing. A number of them—and among these are the most highly valuable and important ones today—deal not so much with the tubes themselves as they do with the machinery for making tubes—such as the stem-making machine patent partly described in the first part of this story.

The biggest and most fundamental tube patent of all times—and one which unfortunately has netted its inventor the least return—was Dr. De Forest's patent dated February 26, 1908, wherein he distinctly specified the interposition of the grid between the filament and the plate of the old two-element Fleming valve, thereby creating the first real vacuum tube, as we know it today. This was a truly basic patent; and it absolutely prevented any open-and-above-board independent manufacturing of radio tubes until it expired on February 26, 1925. An efficient radio tube is an impossibility without a grid. Even the placing of an unusually-shaped grid beside the filament, instead of between the filament and plate, as was essayed by one company, was adjudged an infringement by radio-tube engineers and legal experts, with the result that the infringers virtually had to desist until the expiration of the grid patent.

Then there was a company, as long ago as 1915, which in an absurd effort to beat the grid patent, advertised a tube

with a grid mounted *outside* the plate element; in fact, it was clamped around the outside of the glass bulb. When I saw it I was puzzled as to how that tube could work; and it cost me five dollars (I bought one) to find out that it didn't work.

The most bitter and interminably prolonged battles over radio tubes have thundered around this now dead but once almost priceless grid patent. Because of it, an immense New York factory was torn up by the roots and moved bodily over to the Jersey shore. The New Jersey laws, incidentally, seem more favorable to the operation of corporations of murky legal status than those of any other state in the union. If it is true, as has been alleged, that these flexible laws were framed for the benefit of the larger corporations, then it has proved a disastrous boomerang to some of them; for the smaller concerns, particularly including tube-making companies, acting cheerfully in accordance with the old saw that what is sauce for the goose is pie for the gander, have taken advantage of these New Jersey laws to the fullest possible extent.

The dead grid patent is not even allowed to rest at peace in its grave; it is still a bone of mighty contention, inasmuch as its original owner demands an accounting of past profits on radio tubes manufactured without his legal consent before it died. In a court-famous document signed by him at San Francisco in 1915, he granted a company what he considered to be a limited right to the use of his grid patent; but somehow it turned out to be an unlimited right, and not only were immense quantities of tubes manufactured under it, but the inventor was almost stopped from making any tubes in his own factory. This Arab let the camel merely put his nose to the tent-flap; whereupon the camel promptly ate up the tent, blankets, Arab and all. But this is a squabble over a thing that is past; it is of no significance in the tube business today.

There is, however, at least one unexpired basic patent affecting radio tubes. It is not strictly a tube patent; it deals with processes and equipment for drawing and thoriatizing tungsten wire—the base of the radio tube filament.

The only successful method, so far, of drawing tungsten metal into a fine wire suitable for use as tube filament was

accidentally invented by an Austrian named Hahnemann, in 1912. He sold his patent rights to an international corporation for about half a million dollars. It is of interest to note here that for some time it was completely unknown that the activity of a radio tube filament was due entirely to the electronic emission of a thorium content in the tungsten metal. If the thorium had not accidentally been there as a rare adulterant of the tungsten, the tubes never would have worked; and quite possibly would not yet have been discovered or invented.

The moment it was found that the thorium content was what emitted the electrons from the filament, and not the tungsten, steps were taken to enrich the thorium element by artificial means. In connection with this, the patented cold-drawing of the tungsten wire is an essential factor. This tungsten patent, which has four more years to run, would, if it could be strictly enforced, almost inevitably put every unlicensed tube manufacturer in the country immediately and completely out of business.

But the tube manufacturers, wisely, do not make their own filament wire. They buy it. If, as is the case in one or two instances, a tube-maker has anything to do with a tungsten-thoriated laboratory, then it is operated secretly and separately; it is not in the tube factory. The company previously referred to as making a tube with a peculiarly-shaped grid is trying to beat the tungsten patent by using a filament of thoriated molybdenum instead of tungsten—but with poor success. Their tubes are short-lived.

Undoubtedly, the tube manufacturers could be attacked for using infringing tungsten filament wire, even though they do not make it themselves. But there are several reasons why an attack upon the tube-makers by the owners of the tungsten-wire patents would be extremely difficult.

For one thing, it is doubtful whether it could be satisfactorily proved in court that a piece of alleged infringing filament wire really was made by the patented process or by some other process. The cold-drawn wire is so confoundingly small that it might seem hard to prove whether it was really a piece of the defendant's tungsten or a couple of hairs from the head of the plaintiff's blonde stenographer. Nobody in a courtroom would believe that such fine, hairlike stuff could contain all the infringing quarts

and gallons of electronic brickbats that the engineers testifying for the prosecution would try to prove it contained; the judge would go half-blind trying to see it; and the battling lawyers would lose it. And, far worse than this, the patent-owning company, in order to state their case, would have to lay before the court a great mass of jealously-guarded secret facts and formulas; which the gang on the other side of the fence would be writing down in their notebooks so fast they would make their pencils smoke!

If the patent-holders could drag the defendant's wire-drawing machinery into court, they probably could prove their case; but these wire-making laboratories are mostly kept out of range of even the most high-powered legal rifle that can be brought into action against them. Either they are operated with such extreme secrecy that Sherlock Holmes himself could live and die over one of them and never suspect that it was around, or else they are located in Africa or Iceland, or some other equally inaccessible spot.

It appears rather improbable, therefore, that much of anything will be done by the owners of the tungsten wire patent toward trying to stop the manufacturing of infringing filament wire—especially in view of the fact that this patent has only four more years to live. There is one scandal sheet published for the special edification and exasperation of persons engaged in the radio manufacturing and merchandising business that has been yapping and yelping and egging on the tungsten patent-owners to come on out an' fight; but the only response from the elephant in the jungle is some ominous trumpeting and rumbling that occasionally grows loud and vexed enough to make all the little dogs turn and scoot in alarm.

A far more efficacious method of warfare favored by the holders of the big patents is being carried on today by deflecting the millions of dollars that might be wasted in fruitless litigation into costly and ceaseless advertising, which is marvelously potent, in time, to mold public opinion and confidence.

With the exception of the tungsten patent, there seems to be now hardly anything at all to prevent unlimited manufacture of radio tubes of the more popular types, by

anyone who cares to go into the expensive business of making them.

There do not appear to be any particularly important patents affecting the new high-mu tubes lately appearing on the market. The mechanical difference between a tube of high mu or high conductance and one of low mu or low conductance is merely that the high-mu tube has a much more closely wound grid than the other—with the result that the slight potentials applied to the grid have far greater choking effect on the electronic emission from the filament to the plate than they do in the case of a low-mu tube with a coarse grid. It is apparent, incidentally, that high-mu tubes are far easier on *B*-batteries than are the usual 201-*A* type.

It is becoming more and more needful, not only in the name of common fairness, but to avoid confusion in our own minds, that we should cease from referring to some radio tubes as bootlegs and to other tubes as not bootlegs. A bootleg tube, as has been often pointed out, is properly a deliberate counterfeit of some much-advertised make. There are at this moment large quantities of tubes, thousands indeed, being sold, falsely bearing a well-known trademark and packed in a well-known box. Sleuths in the employ of the Radio Corporation of America are reported to have run down a big outfit that was turning out such perfect counterfeits of Radiotrons, including the container, that the only immediately evident clue to their spuriousness was a slight difference in the shade of red ink used to do the printing on the carton. These counterfeits, ninety-nine times out of a hundred, are foisted upon the unsuspecting public over the counters of the drastically cut-price radio stores.

The fact that a \$2.50 Radiotron or Cunningham tube is advertised by some store for \$1.69 or \$1.62 does not necessarily prove the tubes to be counterfeit; but it should interest the reader to be informed that no retail radio dealer anywhere in the entire United States today can himself buy these tubes for a cent less than \$1.72 apiece, spot cash. Some radio merchants do at times sell a few of their goods at cost price as leaders or trade-pullers; but when one of the biggest-selling items of a radio store is continually

offered at pretended cost price or less, then it is time to take that concern's advertisement with several grains of salt.

In concluding this story of radio tube patents, I may remark that there is a rumored possibility of further warfare over the big-production stem-machine patent that I have described; because of the fact that this glass-working patent mentions the use of compressed air in the course of the manufacturing process. The use of air in a process is a pretty broad specification; and under it even the new non-infringing machines may be attacked; but the Hungarian wizard in Newark, who builds practically all of the world's tube machinery, other than that used by one company, has still another revolutionary new airless machine in readiness, to be dragged out the moment the glass storm breaks around him again. The thicker the safemakers build their doors, the hotter do the safe-busters make their oxy-acetylene flames; or, when that fails, sometimes they bring along a truck and a derrick, and carry away the darned safe entire.

American Business Magazine in September 1927 headlined the litigation: CHARLES EISLER WINS VICTORY: THE EISLER SYSTEM OF TIPLESS LAMP AND TUBE MANUFACTURE IS NOT AN INFRINGEMENT, COURT DECLARES, and went on to report:

Charles Eisler, noted inventor and president of the Eisler Engineering Co., of Newark, New Jersey, is to be complimented upon his complete vindication in a suit instituted by the General Electric Company against his organization, in which it was alleged that the Eisler system of tipless lamp and tube manufacture was an infringement on processes to make tipless lamps and tubes as patented by the General Electric Co.

Mr. Eisler of course, defended this action not alone in the interests of the company, of which he is head, but in the interests of those who utilize its products, as well as those who manufacture under a licensing agreement with his organization. While the legal decision affecting this case is by no means now news, we bring it to the attention of our readers, nevertheless, to show the type of business management that has characterized Mr. Eisler's connection with the electrical industry.

The company of which he is the head has been built to success because of the quality of its product and the efficient executive management of Mr. Eisler. The company, therefore, has not been dependant for success upon the ideas or patents of others, and Mr. Eisler is a man of such inventive ability that his efforts have been responsible for various products that heretofore were unthought of.

The radio industry, since its inception, has been marked by continuous patent litigation. Mr. Eisler has at all times been an adherent of fair play and fair trade practices, and to accuse him and his company of infringing the rights of others was absurd on the face of it. His efforts have always been directed to the keeping of his industry clean, so naturally it was preposterous to believe that he would be guilty of such an act as charged.

However, as we have pointed out, he has been vindicated, and he is to be complimented on the steps he has taken to safeguard the interests of those whose welfare his company has continually at heart. His success in this action more than ever justifies his standing of leadership in the electrical industry, and he has proven himself big enough to stand on his rights even in the face of criticism by such a big industry as the General Electric Co.

A feature story in the Newark *Sunday Call*, February 1928, headlined me: NEWARK ENGINEER AND INVENTOR IS A CHAMPION "TRUST BUSTER," and went on: CHARLES EISLER, HEAD OF FIRM HERE, SO VERSATILE THAT HE MANAGES MEN, MACHINERY AND MONEY FOR HIS COMPANY, BESIDES BEING ITS STELLAR SALESMAN. The full story followed:

"Trust busting" as a political pastime has ceased to be indulged in extensively, but as a policy for small business concerns it still finds much favor and is considered absolutely essential in some industries. One of the champion "trust busters" in the United States is Charles Eisler, who lives at 94 Girard Place, this city, and is president of the Eisler Engineering Company, Inc., whose plant is at 760 South Thirteenth Street.

Mr. Eisler's firm supplies machinery to seventy-five independent manufacturers of radio tubes throughout the nation. Of these, twenty-one are in Newark and about ten

more in other parts of this state. The independents, Mr. Eisler recently told the Federal Trade Commission in Washington, D. C., produced 9,000,000 radio tubes in 1926 and probably 15,000,000 last year.

As part of his contribution to the radio industry, Mr. Eisler devised and patented a process for the tipless manufacture of incandescent lamps and radio tubes to supplant the old-fashioned tip which had marred the products of the independents previously. The powerful General Electric Company contended that the Eisler process was an infringement on its own patented method for tipless tube manufacture.

Then began a three-year legal battle in the courts, with Mr. Eisler in the role of "trust buster." The case first came before the Federal District Court for New Jersey, with Judge Bodine presiding. General Electric lost, but carried the case to the Federal Circuit Court of Appeals at Philadelphia.

Judges Wooley, Buffington and Davis, on the bench of that court, ruled almost a year ago that the Eisler process was no infringement, and so the Newark man emerges for a second time victor in a legal battle with a large corporation that has often been called a trust. It was said at the Eisler plant yesterday that this triumph marks the end of the suit and that no further recourse is left open to the complaining company.

Inasmuch as the tipless tube and lamp process used by the Newark firm is the invention of Mr. Eisler himself, these court decisions serve to increase the reputation that he had already won in the industrial world as an inventor. Practically all the machinery used in his plant was designed in whole or in part by him.

What is more, Mr. Eisler is a skilled machinist and engineer as well as inventor. His associates say that apparently he can run every bit of apparatus in the plant. Often he will walk up to a machine and show its operator, no matter how experienced, ways to handle it to better advantage.

Such a practice naturally keeps Mr. Eisler in close contact with everything that goes on in the factory. Furthermore, being of the executive type, he is in complete command of affairs there at all times. There never is any

question who is the "big boss" at the Eisler Engineering Company works.

Mr. Eisler's flair for leadership is exemplified by the fact that he is both president and treasurer of the company. He knows how to manage not only men and machinery, but money as well. No detail of the business escapes him. He is as familiar with the office routine as he is with that of the factory.

Mr. Eisler has still another trait that one would hardly expect to find in one of an inventive, mechanical turn of mind. He is a crackerjack salesman, the "star" of the company, in fact. Right now, for instance, he is on a long trip through the South and Southwest, demonstrating the merits of his company's machinery to prospective customers. He goes abroad once and sometimes twice a year for the same purpose.

In Pennsylvania the *Philadelphia Sunday Item*, March 11, 1928, called me the **BENEFACTOR IN THE RADIO TRADE**, and went on:

After three years of strenuous litigation, the Federal Circuit Court of Appeals in Philadelphia met and Charles A. Eisler won a sweeping victory against the General Electric Co., which had sued Mr. Eisler, claiming that his invention of a tipless radio tube was an infringement on their patents. There is now no opportunity for any further trials as it is closed in a manner that precludes any further technicalities ever again opening the case. This is a decided victory for Mr. Eisler, who has stood indefatigably and steadfastly by the courage of his own convictions. But it is more than a personal victory, for it emancipates all radio tube manufacturers from the yoke that would have otherwise bound them from carrying on their business. So Mr. Eisler is in the position of a great benefactor in the interest of the entire trade which owes him a lasting debt.

It is therefore interesting to get a close-up of Mr. Eisler, who is one of the most interesting and accomplished scientists in the world, and who has sought, like so many men of science, to hide his genius in the background. But a man who has attained to his position should be better known and he should not be over-modest. He is the president of

the Eisler Engineering Co., Inc., of 760 South Thirteenth Street, Newark, New Jersey, radio and lamp tube manufacturers, and also makers of machinery used in the manufacture of these tubes and lamps. Their goods are shipped to every country, and their catalog is a sort of manual in every part of the globe. In fact, this is a direct result of his own personal salesmanship as he has visited every country, speaks five languages and is in a better position to exploit his goods than would be anyone else, because of his close knowledge of every detail of the business. The reader will better understand the significance of this when we reveal the fact that it was Mr. Eisler who invented all this marvelous machinery as well as the processes.

Some idea of the importance of this machinery is to be seen in the recent newspaper criticism in Hungary, lamenting the fact that Russian radio tubes were so seriously competing with all others throughout Europe. The reason for this ability to meet all competition is because Russia uses Mr. Eisler's machinery for making these tubes. Some time ago they placed a large order which Mr. Eisler's company filled so satisfactorily that a repeat order will shortly be forthcoming. In fact, Russia has sent to Mr. Eisler a special transport and has called him to Russia to investigate the radio tubes and lamp conditions, and they have commissioned him to modernize their electrical industry; certainly a signal compliment to his genius. Mr. Eisler has visited Russia and was in Moscow and also Leningrad. However, now, the Eisler machines and tubes are to be found all over the world.

Mr. Eisler is both president and treasurer of his company, both scientist and engineer, both executive and salesman, besides possessing all the attributes of a seasoned diplomat, understanding foreign customs as well as five languages. But in Newark he is one of the leading citizens, civic-spirited and highly esteemed by all. He is a director of the Clinton Trust Co. and of the Port Newark National Bank. His life and achievements constitute real romance of science, commerce and industry, and we are honored to place him in our column of notables.

EISLER ENGINEERING COMPANY, INC., ARE NOT GUILTY OF INFRINGEMENT, the *National Business Review* announced in May 1928, and reported:

The attempts of nationally affiliated industrial enterprises to gain recognition in the courts by means of unjustifiable and unsound lawsuits, in which they have no stronger claims than that of wealth, is a subject for regret.

A recent case in point is that of the Eisler Engineering Co., which, gratifyingly, emerged victorious from a suit brought by the General Electric Co., inferring that the Eisler concern was infringing on rights of the company.

Upon investigation, the courts found that Mr. Charles Eisler, president of the Eisler Engineering Co., did nothing other than adopt an efficient means of manufacturing incandescent lamps, which had formerly been employed by General Electric Co. Though the method was a time-saving one, it involved no patent, nor could it be considered an invention.

It, indeed, seems foolhardy of General Electric Co. to have caused litigation on so weak a stand when Eisler is widely recognized in his field as an electrical engineer of first rank. With his extensive experience and constructive career in his field, it is hardly to be expected that he would make a mistake in so obvious a means of bulb construction.

The *National Business Review* commends Mr. Eisler on his most recent victory, and commends him on the invaluable work done by his far-reaching company. It will, doubtless, long continue its worthy service, and stand forth as one of the greatest in its field.

The *Radio Retailer & Jobber* on January 12, 1929, welcomed the decision: **EISLER COMPANY WINS SEALING-IN CASE BESTING GENERAL ELECTRIC CO. 4TH TIME**, and went on:

As a triumphant result of years of strenuous and costly litigation, Charles Eisler and the Eisler Engineering Company, Inc., of Newark, New Jersey, have again won a sweeping victory against General Electric Company, which, alleging patent infringement, sued Charles Eisler and Eisler Engineering Company for the alleged infringement of a sealing-in operation of a machine essential in tube manufacture.

Judge Bodine, of the United States District Court, sitting at Trenton, New Jersey, on December 21, 1928, ruled that the Eisler sealing-in machine does not infringe the

patent held by General Electric Company relating to similar mechanism and the process thereof.

This is the fourth decisive victory for Charles Eisler and Eisler Engineering Company against General Electric Company in the past few years.

In the first of the four suits the powerful General Electric Company contended that the Eisler process of making tipless tubes and the stem machinery incidental thereto were infringements of its own patent, of different conceptions and execution. The second litigation involved the tipless-stem method for making lamps and tubes. The third victory related to the inserting of the wires into the cane glass for the lamps.

An abstract from the judge's opinion in this latter case reads as follows: "Eisler has gone back to the old hand art, and, instead of discarding that art, as the General Electric Company did, has utilized it, by simply transforming the method and means of that hand art and has embodied that hand method in two separate noncooperative, automatic machines." (This concerns the wire-inserting patent.)

Aside from the triumphs of Charles Eisler and the Eisler Engineering Company, these decisions have emancipated tube and lamp manufacturers from the yoke that would have restrained them from successfully carrying on their business ventures, in which millions of dollars were invested. Therefore, Charles Eisler is to be considered as a great benefactor of the lamp and tube industry.

Mr. Eisler, of course, defended these actions, not alone in the interest of the company of which he is the head, and which bears his name, but also for the benefit of those who utilize the products bearing the Eisler trade-mark.

The Eisler Engineering Company has attained extraordinary success in its highly-specialized and most exacting art and science, because of the demonstrated and unsurpassed quality of its products and the efficient executive management of Charles Eisler himself. This company has not been dependent for success upon the ideas or patents of others, as Charles Eisler is a man of inventive ability, and it has been due to his efforts that Eisler machinery has become world famed.

The Eisler Company specializes in new, original and patented machinery, specifically designed for the manufac-

ture of radio tubes, lamps and allied products, and the apparatus, conceived and created solely by the engineering staff of this concern, embraces and includes every operation and process in the production of those commodities.

In the April 1929 issue of *American Business Review* tribute was paid to the Eisler Engineering Company for CONTRIBUTING MUCH TO PROGRESS OF RADIO INDUSTRY:

The radio industry has gone ahead with leaps and bounds in the past few years, and behind this great progress and this fine achievement have been the competent engineering firms of the country who have constantly added new equipment to the radio field, extending every facility to meet every need of that field.

Just such an organization as this is the famous Eisler Engineering Company of Newark, New Jersey, which was founded by Charles Eisler, one of the most prominent engineers in the country, and which is the largest manufacturer of radio tube parts and radio tube production manufacturing machines in the world.

This company has constantly added to the equipment necessary in the radio field, and the great success of the company has been founded on great engineering work by a competent staff of experts under the personal supervision of Mr. Charles Eisler.

Among the radio factories using Eisler equipment are De Forest Radio Company, Sonatron Tube Company, United Radio and Electric Company, Ceco Mfg. Company, Raytheon Mfg. Company, Televocal Corporation, Cable Supply Company and *La Radio Technique*, the latter the greatest radio plant of France.

The January 1950 number of the *New Buyers' Register* took a backward look, noting that LEGAL BATTLES HIGHLIGHT RISE OF EISLER COMPANY OF NEWARK, and that:

In 1920 Charles Eisler, a machine-designer and engineer, started his own business by launching the Eisler Engineering Company in Newark, New Jersey, *but* there were several big organizations that weren't too keen on what he was doing.

Recognizing the vast potentialities of the new radio industry, Eisler began manufacturing machinery for the independent producers of radio tubes and incandescent lamps. He felt that the new industry had a great future.

Long hours spent over the drafting board and in the laboratory resulted in the design of automatic lamp and radio tube-making machinery. Experiments proved that radio tubes could be made on machines. These machines were built and Eisler's dream of mass production of radio tubes and incandescent lamps turned into reality.

The big organizations, however, did not approve. Almost immediately after he started making his machinery, they initiated suits against him, charging him with infringing on their patents.

After many years of litigation the charges against Eisler were dismissed by the court. His own patents were upheld while many of his opponents' patents were taken away.

This incident held much significance for Eisler and for the independent manufacturers. First of all, the legal victory meant a vote of confidence for their business. But for Eisler himself it was more important. It was the realization of a desire for independence, and it lent support to his innate philosophy of fighting for what he believes to be right.

The legal conflict attracted wide attention with the incident being watched closely by the industrial press. Following the litigation, an ardent writer called him one of the "champion 'trust busters' in the United States."

Today the Eisler Engineering Company is recognized internationally as the largest firm in the world making automatic machinery for the manufacturing of radio tubes and incandescent lamps. He has a staff of more than 180 people working steadily and often this figure goes up to 500. His plant spreads out for 75,000 square feet of space.

Production at Eisler Engineering, however, is by no means limited to lamp and radio tube machinery. Eisler himself holds 50 patents. These include inventions of sealing-in machines, exhaust machine mechanisms, stem heads, ampule-making machinery, annealers and furnaces, vacuum pumps, etc.

Eisler's fiftieth patent relates to machines used in the manufacturing of glass parts, such as syringe pistons,

syringe tips, glass flanges and similar items used in the pharmaceutical industry.

Before he founded his own business, Eisler worked for several years with Westinghouse in Bloomfield, New Jersey, as a machine-designer and chief engineer. This was shortly after he migrated to the U. S. from Hungary.

In 1919 he went to Brooklyn, New York, to supervise the setting up of a plant for the Save Electric Corporation. When this project was finished a year later, he started out on his own.

Eisler, now in his mid-sixties, believes that his success has come about from his insistence on efficiency in production, the ability to create a demand for his own equipment and his careful following of the oft-heard admonition that "the customer is always right."

In his spare time he turns to farming. And when he does so he leaves the affairs of business to his chief aid, his son Charles Eisler Jr., who holds degrees from Massachusetts Institute of Technology and Stevens Institute of Technology.

14. PROSPERITY DE LUXE

TIME PASSED and the Eisler family was increased by two more girls—Ruth born in 1924, and Connie in 1927. The Eisler fortune was also increased. By 1929, when the Eisler Engineering Company was not yet ten years old, I could claim a bank balance of half a million dollars.

Here is how my ladder of success looked: I earned my first \$5 in the United States in 1904 working for chicken-farmer Meyers in New Brunswick, repairing his agricultural machinery, killing and cleaning the chickens and ducks, etc. We worked from daybreak till dusk. I worked harder physically for that \$5 than for any other weekly amount I ever earned.

My first \$10 was paid me in gold in East Pittsburgh by Westinghouse in 1904. I still have that first \$10 gold piece they gave me; I carry it as a good-luck charm.

I hit the \$100 mark when I was working for Studebaker (Metzger Motor Co.) in 1907 as a tool-designer and toolroom foreman. I felt very rich.

The next money milestone came in 1919, when I received a bonus of \$1500 from the Brooklyn company (Save Electric) for leaving Westinghouse to set up its lamp factory.

In 1923 I received \$25,000 for the installation of one of the early radio tube factories in Newark. Charles Chirlestein came to me and said he intended to build a radio tube manufacturing plant and if I could rush it for him there was \$25,000 in it for me immediately, with more to come. I did the job and accepted the first \$25,000 check I had ever received. Incidentally, at the time it seemed like a large amount of money as part payment on a small plant, but apparently it turned into a successful enterprise, since when

Mr. Chirlestein died recently he left an estate of several million dollars.

The first \$50,000 check I ever saw was given me for the installation of a large radio tube plant known as Grigsby Gruno—again a rush job, this time in 1929.

I reached the \$100,000 mark not long after when I shipped a large order of my patented machines for making electric lamps halfway around the world. And still in 1929, I sold a 49 per cent interest in the Eisler Engineering Company to Frank Bonner. For this I received \$750,000.



Above: Charles Jr., Martha and Ruth help me play with our mechanical toys, Newark, 1926. *Below:* The Eisler girls at our home in East Orange, 1936, in authentic Hungarian, Russian, Swedish and Polish peasant costumes I had shipped from Europe. Miss Hesse (standing second from left) was later to become our daughter-in-law.



But the 1929 stock collapse and bank failures cost me over \$450,000. I suppose a man can't keep all his money! Before the depression struck, I purchased for my family an estate on which I spent over \$225,000. Now with hindsight I know this was a wiser move than buying stocks in 1929. We lived in this palace for over twenty-five wonderful years.

↑ ↑

In 1930 I started a Hungarian weekly newspaper, *The*

Newark Hirlap. After publishing it for three years, I found the work was considerably more than I could handle—running my own business and running a newspaper was too much for me—and I turned the paper over to Dr. Paul Acs, who has been publishing it now for about twenty-five years. The purpose of the newspaper was to offset the undesirable feelings created by other newspapers, resulting in bad feelings and disturbances among Hungarian workers. I felt, with other leading Hungarians, that this bias had to be counteracted. It is a liberal, democratic paper, advocating peace, harmony and cooperation. It seems to have worked out well, a great help to local Hungarian-Americans. It has a weekly circulation of about three thousand, with subscribers



New Jersey American-Hungarian Press Association

To all to whom these Presents may come
Greeting:

As an expression of the high personal esteem and fraternal regard in which

Brother Charles Eisler

is held by our members and in recognition of the valuable assistance he has rendered to the Hungarian Press of this State by establishing the *Newark Hirlap*, *Newark Journal* and patronizing it ever since, we have on this Eighteenth day of January, Nineteen hundred and thirty-six at our yearly meeting in Flemington, New Jersey, unanimously elected him an

Honorary Member.

In Witness Whereof we have hereunto set our hands.

for us (and) Secretary *Janics* Directors: *Stephen B. Gunders*
Anthony J. C. 1936
 President

My journalistic enterprises culminated in this award from the New Jersey American-Hungarian Press Association in 1936.

not only in New Jersey but all over the country. Although the paper has been and still is operated at a loss, if it has accomplished the ideals for which it was started—and I think it has—then the sacrifice has not been in vain.

I would like to note in what a democratic country we are living; and the kind of men our leaders are. In a Newark armory, when I was with the National Guard, President Wilson spoke with me briefly; some twenty years ago I met President Hoover in New York City at a banquet of the American Society of Mechanical Engineers. I knew Dr. Lee De Forest well—the last time I met him was at a dinner given

in honor of his eightieth birthday; I met President Coolidge at an engineers' reception in Washington during a convention; I shook hands with President Taft in New York City at a meeting of the National Society of Mechanical Engineers. I have talked with Westinghouse, Henry Ford, Carnegie, Charles Schwab, Thomas Edison, Hyatt (the inventor of



Dr. Lee De Forest making radio tubes with an Eisler spot welder.

LEE DE FOREST LABORATORIES
RADIO ELECTRONICS
5108 WILSHIRE BOULEVARD
YORK 7288
LOS ANGELES, CALIFORNIA 36

LEE DE FOREST, PH. D., M. C. D., D. ENG.
FRED W. CHRISTIAN, JR.
RALPH W. WHISTON

Wednesday, August 11, 1943

CABLE ADDRESS
DE FOLAR

Mr. Charles Eisler
Eisler Engineering Company
740 South Thirteenth Street
Newark, New Jersey

Dear Charlie Eisler:

All informed persons freely admit that the electron tube is as essential an element in our War Effort as are tanks and airplanes. Without electronic communication and control, our modern fighting machines and tactics would be inoperative. But few realize that without glass forming and pumping machinery, the electron tube industry just could not exist.

Eisler equipment therefore is an absolute necessity in our successful War Effort.

From the early days of the audion 3-electrode tube, your machinery has been an indispensable factor in the growth of the radio industry.

Wholesale production methods were impossible without your guiding genius in equipping the large tube manufacturers with the tools of the trade.

The modern radio tube could not exist in its convenient, tipless form without the special methods of manufacture which Eisler engineers have developed.

Personally, I feel especially indebted to you for the superb way in which you have kept ahead of the radio tube industry's requirements, your numerous and versatile products making possible the astounding expansion of that industry, in which, quite naturally, I have taken great pride.

Wishing you continued, well deserved success, I am

Cordially yours,

Lee de Forest

A tribute from Dr. Lee De Forest in 1943.

roller bearings and bakelite), Flander and Metzger, Nikola Tesla, Steinmetz and many other notables.

I have traveled over three-quarters of the globe—by the fastest planes or the most luxurious steamships; have been chauffeured with my whole family through Europe several times; have stopped at the finest hotels, have seen the best shows at the fanciest night clubs, have eaten in the finest restaurants in the world, have had my clothing made at the best tailor shops, etc., etc. For an immigrant who started out at the bottom of the ladder I have lived a very full, happy life. I conquered every obstacle; I have had much success and little failure. For an immigrant this can happen only in the United States—the greatest democracy in the world. Let us pray and hope it always will remain so for the sake of our children and the future generations to follow.

/ /

After I purchased the large home in South Orange, New Jersey, I truly felt like a king in his castle. In its beautiful gardens I planted a lot of climbing roses, my favorite flower. There was plenty of room in spacious layout, and during World War II two of my daughters lived there each with her husband and two children. During those days Mrs. Eisler used a few of the eighteen rooms to conduct her sewing club work for the Army and Navy hospitals. It was truly a beautiful mansion, admired by all who have visited us there. I have never lost the proud feeling of possession and accom-



Our home for over twenty-five years—the Braeside, 321 Wyoming Avenue, South Orange, New Jersey.



Above: Our little home on the lake. *Below:* Our South Orange home outlined with electric lamps each Christmas season.

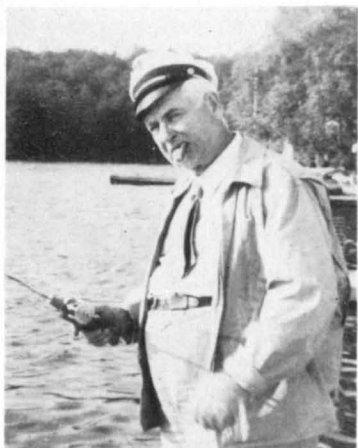

Left: Fishing in New Jersey, 1951. *Right:* (*above*) The log cabin on the Flagtown farm, 1937; (*below*) An aerial view of our South Orange home, 1929.



Above: Plowing on the farm, 1926. *Right:* (above) Astride my horse Jimmy, 1928; (below) Our swimming pool on the farm, 1930.



Mrs. Eisler watches the Eisler children with equine friends on the farm, 1937.

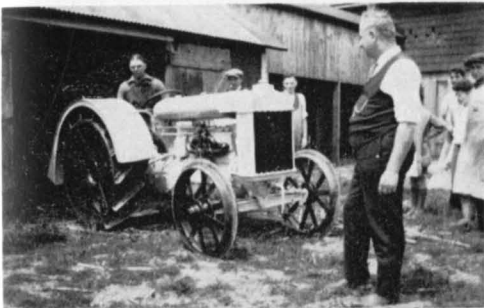

Above: Testing the new Ford tractor. *Below:* Saddling Jimmy for a gallop.





Left: (above) Connie, who was later to marry a veterinarian, with her pet saddle horse Bobo, 1941; (below) The gentleman farmer with three-year-old daughter Ruth and her pet goat, 1926. Right: (above) Showing spring lambs, 1945; (below) Ruth and her favorite horse King, 1934.



At the wheel of my tractor, 1945.



Two views of the cattle and the modern barns (holding as many as fifty head) on the Flagtown farm, 1947.

Above: Ruth flew me over the farm to take this photograph. *Below:* Working over the weekend, 1945.

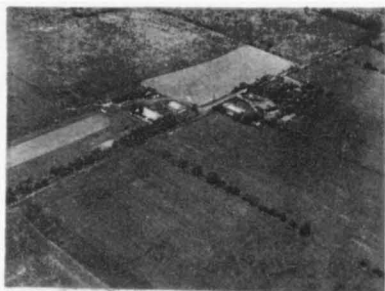

plishment, and also good fortune to have been able to acquire such a home.

(When at last all our children were married and Frieda and I had been living alone for ten years, we decided to make a change and take a smaller house for ourselves. But we will always think back to the inspired and wonderful living we all experienced in our castle.)

From 1925 on we spent our summers on a 150-acre farm in Flagtown, New Jersey. Of course, the children always enjoyed themselves there, as did their many friends whom they invited for long stays with us. There was a large swimming pool and a landing strip for small planes. We grew

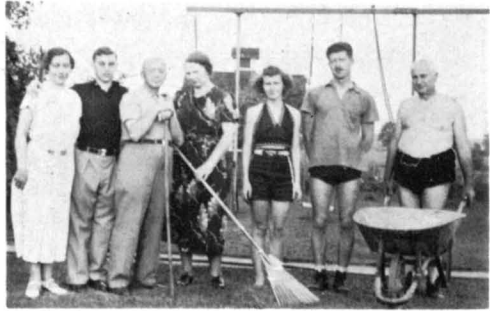

Everyone works on the farm. This was in 1937.



Above: The recreation hall on the farm. *Below:* The farmhouse with its orchards.

plenty of fresh fruit, had our own milk and eggs and we even raised sheep, hogs, cattle and a few goats. Our daughters liked horseback riding from infancy and each girl had her own horse. The fun ended when they had to clean the animals, but those were the rules. My favorite was "King," formerly a circus horse. Whenever he heard a band play, at a picnic or on the radio, he would stand on his hind legs and trot around like an old peacock, but he was good to ride on. I enjoyed farming, not to make a profit but just for the pleasure I got out of it. If I had hoped for a profit, I would have been greatly disappointed and discouraged.

On my own place I could see firsthand why the poor farmer struggles from year to year, barely keeping his head above water. There is expensive machinery, usually requiring repair just when it is needed most; there is no rain or too much rain, not enough or too much sun; there are frost, storms, winds, etc. Because the farmer loves his work and his way of life, he does not seem to mind—probably does not realize that he is always struggling just to make a bare living. As a hobby, I looked forward to plowing, planting, cutting hay, husking corn—it was actually a form of relaxation for me, and I waited impatiently for the weekends. I was a gentleman farmer, which means I earned my money in the city and spent it on the farm. I once calculated that it cost me \$1.50 for a dozen eggs, compared to the 75 cents a city dweller paid. This is taking into account the expensive machinery, the hired help—with their high wages and good living quarters—and the other expenses of running the farm. It was a costly form of relaxation, but we all had a wonderful time.

Every once in a while someone sells me a good idea on how to make the farm pay. I am persuaded to buy thirty head of cattle to raise for beef. I pay about 23 cents a pound. By the time they grow up to full size, in some seven to ten months, cattle prices go down in the West because of the dry season, and down goes the price of cattle in the East. Then we farmers have to sell quickly before the Western cattle reach the East. Consequently there is no profit—and that has been going on for twenty-eight years. However, as I said, I love the farm and the open country.

The blacksmith's anvil has had a tremendous attraction for me ever since I was a boy of nine. Whenever I had a little time, I would go to the corner blacksmith's shop and pull the air blaster for him. The blacksmith was glad to have a boy come in and help. There was a very old blacksmith shop in



Károly learned blacksmithing as a boy in 1897.

Buda. The *mester ur* was an elderly man by the name of Eksten. He taught me all the rudiments: how to heat by coal fire, the art of welding, wagon fitting, etc. I was only eleven years old, but this type of work appealed to me. Even today I have a blacksmith shop on my farm, and in my spare time I do a little blacksmith work. As a matter of fact, I always loved to make things from steel and wood. The sound of the blacksmith's anvil still has attractions for me.



Since I had had a part in the early days of aviation, and the children often came across old pictures of my 1912 flying career, it was only natural that they should have a special interest in flying. But who would have thought that Ruth, the "middle" daughter, would take to aviation so well that in 1940 she became one of the youngest pilots in the state. Ever since Ruth was a little girl she would tell me, "Dad, I am going to have my own flying machine." At the age of fourteen she wanted to fly. I sent her to the Caldwell, New Jersey, Flying School where after a few lessons she showed a



THE DAILY HOME NEWS
 NEW BRUNSWICK, N. J.
 THURSDAY, SEPTEMBER 25, 1941.

South Orange Girl at N.J.C.
 Arrives With Her Own Plane



Left: Ruth, New Jersey's youngest licensed pilot, pictured in New Brunswick Daily Home News, September 1941. Right: Ruth climbing into her Piper cub.

In N. J. C.'s comparatively brief history, freshmen have arrived on campus with a great variety of personal possessions but this year for the first time, one has brought an airplane.

Miss Ruth Eisler, daughter of Mr. and Mrs. Charles Eisler of South Orange arrived bag and baggage with the class of 1945 but her luggage differed from that of her classmates because most important items to her are her flying clothes and pilot's license.

Miss Eisler, the youngest aviatrix in the state, received her license September 13. Monday she took her younger sister, Connie, aged 15 years, for her first flight and Wednesday she left home for N. J. C.

Flying has been one of the freshman's ambitions as long as she can remember. She was air-minded almost as soon as she could think for herself and her determination to fly became stronger when an aviator, with some minor engine trouble, landed on her father's farm in Flagtown, while the family was there on a holiday. Ruth looked the plane over, asked a lot of questions and announced to her father that she was going to fly. Mr. Eisler offered no objections because he too is air-minded. He is a mechanical engineer and as

early as 1910 was building "flying machines."

In March, 1940, Ruth began to take flying lessons at Caldwell Airport, and last November, her father gave her a plane, a Cub-Coupe, which she keeps at Hadley because it is mid-way between the family's winter and summer homes.

Miss Eisler is anxious to become adjusted to college life so that she can see how much time will be left for flying.

She has no great ambitions concerning flying, doesn't care particularly whether she achieves a commercial pilot's license or becomes a stunt flyer. She likes to fly better than anything she has ever done and only hopes that her college friends will want to go up with her so that she can share her enthusiasm. Flying, she claims, makes her feel better. "If I can't get off the ground occasionally," she says, "I just don't feel right."

Ruth likes New Brunswick, she loves her room-mate, she thinks N. J. C. is wonderful, she knows she is going to enjoy her course in journalism but most of all—she is crazy about flying.

Even as a freshman aged 18, the aviatrix is beginning to wonder what newspaper will want a flying reporter four years hence. —V.W.J.

Ruth's appearance on the campus, as a flying freshman, inspired this article.



The retired aviatrix with her husband and family. *Left to right:* Noel Stephanie, Ruth, Leslie Carol, Dr. Arnold W. Forrest and Jennifer Nan.



Daughter Martha with her husband and children. *Left to right:* Cynthia Nan, Martha, Dr. William A. Neff, Bonnie Joy and Linda Gail.

very good aptitude for flying. After about two months of training she received her pilot's license. She was fifteen then and I bought her a new two-seater Piper Cub. She was the youngest aviatrix in New Jersey and she did quite a bit of flying around Jersey. When war broke out her plane had to be turned in to the government, and that ended her flying career. Now with three daughters and her husband, Dr. A. Forrest, she is kept so busy that she has no more time for flying, but she might have made a good pilot.

Charles Jr. wanted to be a pickle manufacturer ever since he was a little boy. He liked nothing better than dill pickles, and he figured if he produced them he could have all he wanted. But I made sure that he should not be without engineering knowledge, and kept him well supplied with all kinds of mechanical toys, steam engines, trains, etc. Before long he could understand every mechanical toy on the market. He took to mechanics and when he was thirteen he started fooling around in the factory, picking up a general knowledge of the operations here and there. At fourteen he already had a good grasp of machine-shop procedure and I

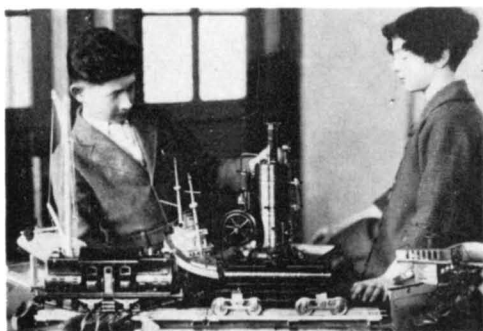

Above: Charles Jr., later to utilize his mechanical proclivities as president of Eisler Engineering Company, explains a steam engine to his sister Martha, Newark, 1925. *Right:* (above) Charles Jr., 1938; (below) Charles Jr. on his new motorcycle, 1932.



decided that he spend some time in a local foundry to learn what he could there. He always came home looking like a chimney sweep, and his mother said I was trying to kill him with "dangerous" work. Little by little, the pickle manufacturer was transformed into an engineer.

When Charles was seventeen he wanted a motorcycle, like the other boys in the crowd. Since I was sure he was going to be an engineer, I figured that a motorcycle would give him additional experience with machinery. There was always something to be fixed on that machine.



Charles Eisler, Jr., receiving his M.S. degree from Stevens Institute in 1938.

He was graduated from Stevens Institute with an M.E. degree and from MIT and Stevens with the E.E. and M.S. degrees. He is quite proficient in the calculation of complicated mechanical movements.

Now he has children of his own: a son who from all indications will be an engineer too, and two girls who plan to become teachers. His wife is the former Beulah Hesse of West Orange, New Jersey.

The graduate degree from Stevens was obtained several years later when he decided he would like to do a little extra



My son and his family. *Left to right:* his wife Beulah, Charlene R., Sharon C., Charles D. and Charles Jr.

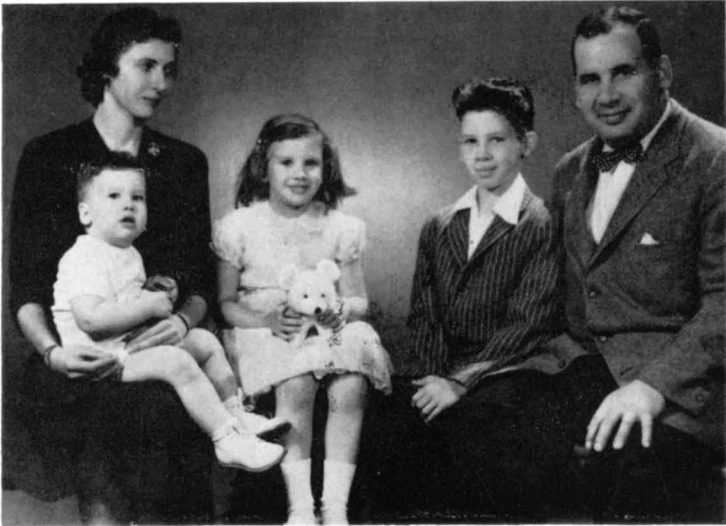

Daughter Constance with her family. *Left to right:* Constance holding Andrew Emil, Suzanne Julia, Stephen Eisler Smith and Dr. Harold M. S. Smith.

studying; in spite of the fact that he was married and had three children, he went back to college for four years, attending night classes, and received his master's degree in metallurgical engineering.

My oldest daughter, Martha, the first Eisler born in the United States, is married to Dr. William Leff. They have three children. During World War II her husband was in the Army and Martha stayed at our "castle" with her two children, sharing our home with Ruth and her two children.

Connie, the youngest, is married to a veterinarian. She maintains a stable of fine-looking horses for riding—still her favorite sport.

The Eisler children and their families are possessions to make any parent proud.

15. VISITS TO RUSSIA

MY FIRST trip to Russia was in 1924, when I went to examine a lamp factory in Moscow that had purchased Eisler machines. I stayed at the Grand Hotel, having paid a New York company in advance for first-class accommodations. But Russia had suffered deprivations and hardships since World War I and most of the doors of this once fine hotel had rat holes in them. It seems the rats had been entering the structures through the water pipes rendered dry on account of the severe water shortage in most of the large cities since the start of the war. There still was no heat or electricity, and very little food. Most stores were still closed in 1924; only a few government-operated shops were open. What little food was available was limited to the factories. In fact, all food purchases had to be made through requisitions in the plant where the people worked. Meals were served there too. Another item you could not find in Moscow was soap; if you did not bring your own, you simply did without it.

During my brief stay in the Soviet Union I managed to take in Leningrad as well as Moscow. In both cities then every street corner was bedecked with pictures and busts of Leon Trotsky, and of course Lenin's picture was seen everywhere. (Three years later all of Trotsky's pictures were removed and the predominant pictures and busts were those of Joe Stalin.)

I had heard so much about Trotsky that I wanted to see what he looked like in person. The hotel clerk told me he could be seen any morning at 7:30 at the entrance to the Kremlin. The next morning I stood in the bitter cold in front of the large Kremlin door. At 7:30 the large official automobile approached. I was alone, and I could not make up my mind what to do; impulsively, I raised my hat, and

everyone in the big car saluted. There were Trotsky, Stalin, Kaganovitch and Bulganin; the others with him I did not recognize.

Later that same day, I returned to the Kremlin. I wanted to see Lenin's tomb. But when I saw the long line of people

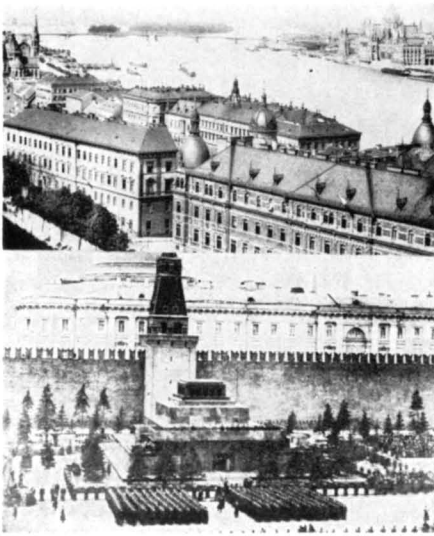

Above: Margaret Island can be seen in the background of this view of Budapest, 1948. *Below:* Lenin's tomb in Moscow, 1924.

before the edifice, I became discouraged, since I could not wait in line that long. I took a chance and went up to the uniformed guard; I told him I was an American engineer and pointed to the long line. As luck would have it, he motioned for me to go in. Inside, I looked down at the little red-headed man encased in glass, surrounded by black marble. There, lying quietly, even innocently, was the man who has changed not only Russia but possibly the whole world. It was a sight I shall never forget.

I saw something else in Russia in 1924 that impressed me. In the large lamp factory I was visiting two engineers were lecturing on the vacuum in the incandescent lamps, etc., during the lunch hour. It struck me that in the United States there were few workers—and still are to this very day—who know more than the bare essentials of their own product. They are not familiar with the technical informa-



The main entrance to the Kremlin. During 1647-1917 no man was permitted to pass with covered head the beautiful *Spasskiya*, or Redeemer Gate, built one year before Columbus' discovery of America. It was used by religious processions entering and leaving the fortress, and by the czars for their ceremonial entry at their coronation.

tion that so often helps make more efficient and more capable workers. And it would be an almost impossible task here to get workers to listen to lengthy though informative lectures on their own time. With today's unionized setup, our workers would probably demand time-and-a-half for such an undertaking as the lunch-hour session I observed in Russia.

Whenever I visited Russia, Frieda and the children would remain in Budapest with her parents. On one of these occasions, when Charles Jr. was about eight, they were in a Budapest restaurant, and he ordered lobster soup. This was unheard-of in that part of Europe at the time, and before long there was a small crowd around the table watching him. Of course he had learned to eat lobster in the United States. Similar experiences occurred when I was in Budapest and ordered raw tomatoes or cucumbers. The people gathered around waiting for me to be rushed to the hospital. Tomatoes and cucumbers were supposed to give a fever and were considered poisonous by many. When I was a boy, no one dared eat raw tomatoes or cucumbers unless they were first soaked in salt and specially prepared.

I visited Leningrad again in 1930 and stayed at the Hotel

Metropol, which had just been erected. It was a tourist's heaven—caviar was served three times a day. There were four meals a day: breakfast, lunch, dinner and a midnight meal from 11 to 12. My room was luxuriously furnished—gold or gold-plated items everywhere. I had to sign an inventory sheet to guarantee that nothing would be lost or missing on my departure, and before I signed out the maid okayed my clearance.



May Day in Red Square, Moscow, 1930.

At the daily tea dances officials mixed with tourists. The bars were busy and there was plenty of drinking. Dance music and concerts were a feature of every hotel. Of course, all this was mainly for outsiders with foreign money. The best-liked currency was American dollars (no Polish money was acceptable, for example).

Engaging the services of a taxi is practically the same in Finland as in Russia, and I have hired taxis in both countries. The system is that you must bargain with the taxi man. If you don't they will ask at least twice or three times more than they are entitled to, especially when the fare is someone from a foreign country. But I was tipped off before I

arrived. There are no meters and no fixed prices, and a ride usually costs the foreigner 300 per cent more than it does the native.

You go to the last man in the taxi stand and ask him how much he wants from the stand to the hotel. He will tell you twenty rubles, and you tell him it's too much. Then you go to the next taxi man; he will say sixteen rubles. Then you walk to the next taxi man; he will ask fourteen rubles, and you tell him that is too much. You walk away and start to make the trip on foot. The taxi man will follow you and ask you how much you are willing to pay. You offer him half the amount the first taxi man asked, and he will drive you to your destination.



In Newark in the early thirties for about two years I had noticed as I walked through the plant every day that one fellow would always have a newspaper spread open wide on the bench—it was called *Moscow*, with the hammer and sickle on its banner. Of course it was full of Red propaganda against the United States. I told him several times not to bring the paper into the plant and that I would have to discharge him if he continued to do so.

In spite of my several warnings, he persisted: "Mr. Eisler, we live in a free country and I read what I please." I told him that I didn't care what he read in his home, but I objected to such literature in my plant. He went to New York, complaining to the Amtorg Trading Co. that although we did much work for Russia I didn't permit him to read a *Moscow* paper.

Although he had been born here, he was of military age when his father took him to Hungary before the outbreak of World War I, and he was drafted into the Hungarian Army. He was captured by the Russians and, as a prisoner for about four years, he learned Russian fluently. When the war was over, he was returned to Hungary, and about two years later he decided to come back to the United States. He had forgotten all his English and had to learn it all over again. He applied for a machinist helper's position in my factory and

we employed him for six years, until the newspaper incident resulted in his dismissal.

It was suggested to him in New York that if he wanted to go to Russia he could get a machinist's position in the plant there where the Eisler machines were in operation. He and his wife went to Russia at their own expense and both took night jobs as repairmen in the Russian plant.

About three years later, in 1936, I once again went to Russia, and I decided to find out how my ex-employee was making out. I got to his home about 3 P.M. His door was bolted with iron bars and chains.

I knocked, and he yelled out in Russian, "Who is there?"

I yelled back, "Comrade."

His wife opened the door. He was eating—his face was over the soup bowl—and when he saw me, his mouth opened and the food fell back into the soup. After the first shock, he came to me with tears in his eyes, hugging me and at the same time complaining bitterly about his present plight. His "home" consisted of just the one room—about 10 by 10. He pleaded with me to help him get out of Russia; he was unhappy with working conditions, the low pay and the poor housing. He was considered a foreigner, and was not trusted with a day job. The slogan against him, he felt, was "Russia for Russians."

Since he had never been in a hotel or a restaurant there, I invited him and his wife for dinner at one of the best hotels in Leningrad. He was afraid to walk in when he saw the elegance of the hotel. That night I showed him how the Red leaders lived and enjoyed themselves in contrast to the almost slavlike existence of the workers.

He asked me to write to the United States consul in Riga about his leaving Russia, which I did upon my return home. I don't know whether this did the trick or not, but about two years later he arrived in the United States—without his wife. Although she had come to Russia with him, because she was of Polish descent and not an American citizen she was unable to obtain an exit visa. Back in the States, he looked me up to thank me for my efforts on his behalf. He was penniless—in five years he could not save anything in Russia and he had

used up the \$4000 he had saved while working for me. When the Newark workers heard that he had just returned after five years in Russia, they wanted him to speak to them of his experiences there, but he would not talk. Shortly after, he disappeared from our area and I have not heard of him since.



When I had returned from Russia in 1936, I too was invited to speak before clubs, societies and labor organizations on my experiences in the Soviet Union. Among the many groups that invited me was the Hungarian Workers Club. The members at that time mostly favored the Russian viewpoint. I went before them and told them what I saw. I tried to explain the good and the bad in equally unbiased terms. I told them of the beautiful new subway built by the Russian workers, and I recounted my ride in this modern masterpiece—girls in uniform selling ice cream popsicles, the modern escalators, the huge murals, etc.

I told them of a magnificent new building, with a sign on it: THIS BUILDING WAS DESIGNED BY COMRADE ENGINEER ROSENBLUM. It was a multiple dwelling of entirely new architectural design employing the principle that all rooms should enjoy a maximum of sunlight and fresh air.

All this was well received and they all applauded. But then I told them that no worker could live in a new house, that they were for white-collar workers only; I said there were no clothing stores and that men and women had to stand in lines from five to fifteen hours to get bread. I told them the factories worked ten hours, and when the worker was late he went before a committee to be reprimanded; if he talked back to his superiors he might lose his food-rationing card. Broken tools had to be reported to a committee. If the worker spoiled a job he could be sent to jail. There was no other choice for the workman but to remain at his given job. He had to live in only one room and share the kitchen with his neighbor; I noted that I had not seen a worker who had his own car or house or any of the other advantages working people have in the United States. I related that the cooking of all meals was done in the plant canteen, that the workmen were poorly supplied with clothing; everything was rationed, there were no summer homes on the lake or weekend trips,

etc. All these facts made me out to be a very bad man—I was creating propaganda against Russia, the workers' paradise; I was trying to undermine Russian progress, spoiling the good Russian name; I couldn't judge Russian conditions because I was not a worker and did not understand workers' problems.

I showed them my union card in effect since 1904 to convince them that I knew what I was talking about. Over their protests I told them that in my estimation the Russian worker would never have the standard of living of the American worker, not even two hundred years from now, because the

INTERNATIONAL ASSOCIATION OF MACHINISTS.		TRANSFER ACCOUNT STAMP
Lodge No. <i>565</i>		
THIS IS TO CERTIFY THAT		
Bro. <i>Eisler Carl</i>	Member's No. <i>134263</i>	Entered <i>7-2-94</i>
is most experienced at <i>Tool Maker</i> work <i>W.C. Mfg. Co.</i>		
and is entitled to the Rights and Privileges of Membership, as long as this book is stamped in accordance with the Constitution.		
	<i>John Smith</i>	Pres't.
	<i>Anton Novotny</i>	Fin'l Sec'y.

My union card, issued in East Pittsburgh in 1904.

makeup of their whole system was not based on our kind of standard.

The next day in the plant every bench had a leaflet condemning Eisler as a capitalist who drew the last drop of blood from his workers, paying them starvation wages. In spite of this, I attracted a large gathering to listen to me when I spoke in public. I suggested this time that an American worker be sent to Russia to find out for himself what conditions were in Russia. I would donate a part of the traveling expenses. The workers selected a representative to go to Russia. His report, upon returning, was worse than mine.

In the Soviet Union boys as young as thirteen are apprenticed. Thus the Russians are able to put into heavy industry three million skilled mechanics every three years. The industrialization of such a vast country is an important step in their plan for world domination. In the United States we lack this organized apprentice program which is so desirable since the backbone of any country is the supply of its trained

labor force. I see no reason why a healthy boy or girl of fifteen or sixteen could not learn a trade under proper supervision. Our labor laws prohibit teenage employment, but a more practical law would be advantageous: many juvenile delinquents and young jail residents could be made useful to society as well as to themselves if an apprenticeship system were adopted in this country.

↑ ↑

The last time I visited Moscow and Leningrad was in 1938. In Leningrad especially there were many improvements. Old buildings had been remodeled, with several stories added.



Above: The University of Moscow, where Russia's growing army of engineering students are indoctrinated in science. *Right: (above)* Interior of Leningrad subway car; *(below)* Leningrad subway station as it looked on my 1939 visit. There are eight stations, each with its own style of elaborate architecture in different marble. The unusually deep subways are reached by electric stairways, probably the longest in the world.



There were large new American-style playgrounds and I saw modern tractors, more buses and new factories for automobile production. The city boasted of its new hotels, more food and clothing. These were noticeable improvements. In 1924 only black bread was available, except in some hotels which served half-white and half-black bread. In 1938 every conceivable bakery product was offered in the stores. Department

stores and clothing establishments were plentiful. A number of large apartment houses were in evidence; these were reserved for Russian technicians, management supervisors and other higher-ranking officials. In fact, very few consumer advantages were available to the workers. It seems to me that the Russian worker's conditions are no different today than they were during the czars' regime. Obviously, this is the engineer's age in the Soviet Union. He is the one with the better home, more pay and generally greater advantages, both socially and psychologically.

What impressed me most in Russia was that the factories there in 1938 had the finest equipment available—mostly American, English, German and French in design. This wholesale “borrowing” of the latest machine tools and specialized machines from the other European countries will soon put the Russians in a substantially advantageous position in world competition. They will soon lead in the scientific and technical fields, since they have access to all the manpower they need to operate the equipment they have appropriated.

I have returned often to Europe and to South America many times, visiting many of the lamp and radio tube manufacturers there. In every factory there was either an original or a duplicate of an Eisler machine. I don't believe there is an incandescent lamp or radio tube factory anywhere in which Eisler machines are not in use. They are always in great demand in all countries. Even secondhand, Eisler machines bring high prices and are difficult to obtain. Repair shops have lucrative incomes just duplicating and repairing Eisler machines. Regardless of the Eisler patents, my machines were copied everywhere. I figure that at least \$25,000,000 worth of Eisler machines have been copied and duplicated since I patented my originally designed machines in 1915.

But it is gratifying that all over the world Eisler machines have produced such wonderful results. In a number of plants I was told that they were forced to copy Eisler machines because they could not afford to buy them. In some plants my

catalog pages were blown up to full size to make duplicating easier. The more complicated machines and the inner construction could not be photographed, but many engineers admitted that I always supplied sufficient information in my catalogs to make duplication quite simple. An Eisler catalog is always of great help for lamp or radio engineers. Engineers all over the world have a good collection of Eisler catalogs; they call them the lamp machine bible.

In a large plant in Russia the engineer proudly pointed out about 150 different types of Eisler machines—20 to 30 of each type. I had only sold them about 10 or 12 different types. In some cases they had made as many as seventy-five copies. They seemed to like best the coil-winder—I had shipped about 6 in 1924; they had about 50 more in two years. I visited Russia five or six times, and every time I found they had duplicated more Eisler machines of all types. They even wrote a book on the art of lamp-making, showing Eisler machines copied from an Eisler catalog. They did not mention that they were Eisler-patented machines and they said they were made in Russia.

I asked the Russian engineer, "How is it you have so many Eisler machines?"

He said simply, "We like the Eisler machines and that is the reason we duplicated so many right here in our plant."

Patents meant very little to the Russians, too.

I often wondered that we were able to sell machines to so many foreign countries, what with the widespread duplications of them. Today the export of my machines is practically nil unless I have an entirely new design to offer or a high production automatic machine that would take many years to duplicate. Duplication of one or two machines does not pay, so we still receive some orders for the more complicated types that are not suited for mass production. All American machine tool builders will find themselves in the same situation within another few years when most American machine tools will be duplicated by the cheaper labor costs of the good mechanics and engineers that Europe has on call. Our tool manufacturers will then find it very difficult to compete in the world market. Today American-type machines can be

purchased from Europe for 30 to 40 per cent less than their cost here. Agents are reaping large profits by selling European machine tools for only 10 per cent less than the same American-made machine tools. In a saturated market they could sell for 25 to 30 per cent less. American manufacturers would then have a hard time selling their products. On my travels in South America, I have already seen more German, Swedish, English, Austrian, French and Italian machines being sold than American. Because of our high labor costs, we may lose the complete export market. At the present time the productivity of American labor is not better than 65 to 70 per cent of its potential. The American manufacturer has to reckon with high wages and many fringe benefits that result in lower productivity per worker; the European manufacturer, especially in Central Europe, has at least 85 to 90 per cent productivity at lower wages and with fewer fringe benefits.

We will soon be feeling that competition unless we can work out some solution to overcome the dilemma of our high costs, low production pitted against European high production and low costs. Many steps could be taken by our government to keep the export field for us. Our credit system, for one, does not give the small purchaser a chance to buy American products. Because of the scarcity of the American dollar most foreign countries have everybody else's currency but not ours—they purchase from countries whose currency is more easily available. Even with our higher prices, we could still sell if the proper credit arrangements could be made. Without credit, foreigners cannot buy from us. We must find a way to give foreign purchasers three to four years' credit, and enable them to pay in their own currencies. No small companies or even credit banks of good standing can handle this credit on their purchases without the help of the government. Most foreign manufacturers are substantially wealthy in their own currencies but they have no way of obtaining dollars and therefore cannot buy American goods and machinery. It was a more simple matter years ago to get dollars, but today when the rate of dollar exchange is very unfavorable it is almost impossible.

Some years ago I met a lady who, hearing that I had been to Russia, asked that if I went again I should look up her brother, a doctor. I promised her that I would, and did so the following year when I visited Russia for the fourth time. Arriving in Leningrad, I called up the hospital and asked for Dr. X. I was told he was then a patient, having undergone an operation. I engaged a car and drove to the hospital.

I gave Dr. X's name to the attending lady doctor and she showed me to his room. First I had to don a white coat, white cap and white gloves. I walked into the room, and there was Dr. X lying on his back. We chatted for a while about his sister in the United States. His wife walked in. Both were natives of Hungary.

This Dr. X came from a very wealthy family; his father had a large sugar factory and other interests. He himself had been an x-ray specialist in a large Budapest hospital. He was one of the officials of the Béla Kun regime, and when that short-lived republic fell the x-ray doctor was condemned to be hanged in two weeks. The Russians, knowing his abilities, offered to exchange him for two Hungarian generals who had been captured in Psemmisel. The Russians felt he could do more good alive in Russia than dead in Hungary. He was exchanged, and upon his arrival in Russia was made head of the x-ray department in the Leningrad hospital. I talked to Dr. X on three occasions. He was not satisfied with conditions in the U.S.S.R. He told me he had pictured Bolshevism entirely different from what it really was.

I also met in Russia a Hungarian electrophysicist who likewise had been condemned to death, for the same reason as the x-ray specialist. He also had been exchanged—for several high-ranking prisoners of war. He showed me his modern-equipped laboratory in a new school plant built for the sole purpose of teaching young boys and girls in the scientific fields.

Another Hungarian I met in Russia was a patent attorney and physicist in a very large factory. A commissar of public relations in the Béla Kun administration, he also had been condemned to death but was exchanged for Graf Esterhasy, a Hungarian general captured by the Russians.

I met him four or five times because he was connected with a special branch of the electrical industry as an expert. He introduced me to Béla Kun, who was enthusiastic about Russia. That was the country I should live in instead of the United States, he told me.

The patent attorney, however, complained bitterly about unfair conditions in the Soviet Union. He had twice been sent to Siberia to do special work—as a measure of discipline. He had charge of a chemical department making glassware, and was teaching chemistry. His shoes and clothes were in bad shape; buttonholes on his coat twice the size of the buttons, three missing on his badly faded winter coat. At home the furniture allotted to him was in bad condition—stuffing sticking out of the armchair, springs cutting through the seat. I told him if I lived here I would repair it, I would not live like a gypsy. He said, “It does not belong to me. If I repair it and it looks too good, they will allocate it to someone higher up, but if it looks bad no one wants it.”

I asked Mr. Patent Attorney, “How do you like the U.S.S.R.?”

“I imagined it much different,” he replied. “Had I known what I now know I would never have joined the party. It is the greatest disappointment of my entire life.” When I came back to America I sent shoes, clothing, stockings and underwear for him and his family.

An interesting episode on one of my visits to Russia came about through an oversight; my passport had expired about two weeks before I got to the Russian border in Poland. The Soviet immigration inspector told me in very fine English, “Sir, I am very sorry to advise you that your passport is not valid for the Soviet Union.”

I showed him a letter of invitation from the Electrosavot Lamp Manufacturing Unit. Impressed, he said, “We will hold up the train for half an hour. I will make a phone call. Wait here.” In about fifteen minutes he came back and said, “Say, Mr. American Engineer, you can go without a valid passport into the Soviet Union. You must be a big man that you can

do this. When you arrive, give your passport to the hotel man who has charge of passport extension."

When I arrived in Leningrad, a young lady came to me, took my passport and had it extended for sixty days. It seems that the letter from the plant manager was all I needed to enter Russia.

16. *GLIMPSES OF MY NATIVE HUNGARY*

THE FIRST place I visited whenever I was in Europe was my parents' home in Budapest. Eventually my visits led me to the cemetery, where my mother was buried in 1928, followed five years later by my father. They lived together for fifty years. My father always stressed that tolerance, friendship,



At the grave of my parents, Budapest, 1938.

good will and just helping others would enable you to look back on life without regrets. You cannot escape the Grim Reaper; regardless of one's status in life, the Great Leveler has the last laugh.

After World War I wanted to see my folks again. So I went to Budapest and stayed there about five weeks. The sufferings they had been through are almost indescribable. The police had jailed my father because they found a gun in the attic of our house. The attic had belonged to seven or eight tenants in turn, and some soldier home from the war had not turned in his pistol but hid it in the attic. The police had ordered the return of all arms and ammunition, and then went from house to house looking for guns.

Dad was then about seventy and had very little use for arms. The police kept him in jail for nearly a week; every day they would ask him who hid the gun in the attic. When he said, "I don't know," the police official would tell him, "You will stay in jail until you know how the gun got in the attic." One day a higher-ranking official made it his business to check on the "jailbirds." When he saw my father, he yelled, "Get out, you don't belong here!" This official had grown up in the same neighborhood with us. He said, "I've known this old man since I was a boy. He would not hurt a fly. Get him out of here!" He shook hands with old Eisler and sent him home. My dad had tears in his eyes when he told me the story. "There is still justice in the world," he said, "and I am happy to be out of that torture chamber."

/ /

When in Budapest, I visited among the relatives of Hungarian-Americans. In 1934 I went to see the grandfather of a friend of mine, who lived in the small village of Pomáz, about fifteen miles out of Budapest. When I entered the village, I was immediately surrounded by two "gendarmes," village police called "csendörs," the most feared and dreaded soldiers in Hungary. They wanted to know what I was doing there and asked to see my papers. Finally they accompanied me on my visit and waited outside until I was ready to leave. I had visited this man four or five times before, and when the neighbors told the police that I came with greetings from their relatives in America they became more friendly and permitted me to photograph them—which is against the law in Hungary—with the understanding that the picture would not be published in any Hungarian paper. Such was the aura of fear one encountered in Hungary.

/ /

About twenty years ago, while driving through Hungary in my automobile, we had a blowout. The chauffeur repaired the tire and I took a short walk on the dilapidated main highway. As I walked along I met two barefooted peasants,

one carrying both pairs of boots and the other two large sickles. We stopped and I asked where they were headed. They said they were going on a wheat-harvesting job, and had a twelve-hour walk to get there. Their toes were bloody from the stones. When I said I could not understand why they



Above: Hungarian police (*csendörs*) interviewed me to determine the nature of my visit in Szentendre near Budapest in 1938. Satisfied, they posed with me.



Below: Hungarian ranchmen.

did not wear their boots, one explained that if the soles of the boots wore off, he could not earn enough in a year to have them repaired. In our conversation I told them that I came from America and they marveled that I spoke such good Hungarian. I explained that there are as many Hungarians living in America as there are in Hungary. One of the peasants said he had made a mistake, as a young man, in not heeding the advice of a friend to come and work in a Pennsylvania coal mine.

I asked him, "What is the pay for the work that you do?"

He replied, "We get very little money, only a few crowns, but we get four bags of wheat, two bags of oats, three bags of potatoes . . ." He went on to name a dozen more items that he got from this very rich estate. "But there is nothing better at present," he shrugged his shoulders.

“How are you going to carry all this home?” I asked. “You have no wagon and no horses.”

“We never carry anything home. We leave it and sell it to the highest bidder. We get so little out of it when we get through that sometimes it doesn't pay to walk twelve hours for a job, but there is nothing else for us. If we do not accept that, we can't get anything at all.”



Discussing conditions with two Hungarian peasants on the highway, 1939.

This is the lot of the Hungarian peasant who has no property and has to live from the work he does for the three or four months in the summertime. The only country where work is appreciated and well paid for is America.

They had tears in their eyes when we parted and they said, “*Isten Aldja Meg Amerikai Ur*” (God be with you, my American sir).

In contrast to the peasantry, the Hungarian nobility indeed lived at the other end of the scale on thousands of acres of land. The rich landowners had beautiful horses, and they went out riding in their little carriages, usually with four or six horses and one or two uniformed footmen on the sides of the carriage, speeding through the countrysides for all to see them. They loved to attract the attention of the poorer classes.

These rich landowners used to pass me many times with my schoolbooks on my back when I was a schoolboy. Never did any of them have the heart to stop and offer me a



Above: Hungarian nobility out driving. *Center:* Horse-drawn taxis in Leningrad, 1939. *Below:* Horses on the plains of Hungary.

lift to school or back home. As a matter of fact, they would have been insulted if I dared to ask them for a lift.

All Hungarians are proud of their horses. Horse-breeding is still popular, and the animals are shipped all over the world. The horses of the Hussars are famous for their outstanding military performances; the officers rode the finest-looking horses in the world. It is said that when the Russians took over Hungary they sent the Hungarian horses to Russia to be used for breeding there. The American army thought so much of these animals that they brought many of them to America after the war in order to protect the breed. I understand they have since been returned to Hungary by some agreement with the Hungarian government.

Like the United States, Hungary has its cowboys or "ranchmen," mostly in the low parts of the country. These fellows are excellent riders and make much of their tricks and lassos. They are colorfully dressed, wearing embroidered hats winter and summer. The herding of cattle and the branding of the steers date back many centuries in Hungary.

A real old tradition in Hungary is the wheat harvest. The men mow the wheat by hand, making it up in bunches, and then the women load it on the wagons, working alongside the men from early morning till late at night. They are colorfully dressed at this work since it is considered not just an ordinary workday but a holiday. The men too dress up in their Sunday best, in shined boots, white blouses with colorfully embroidered ornaments and white skirts. A generally festive air is part of the tradition.



Left: (above) Hungarian peasant women harvesting grapes for wine; (below) Harvesting time in Hungary fifty years ago; longhorn oxen draw the hay wagons. Right: Choice Hungarian stock, featuring the longhorn oxen in the fields and on the plains.

Another "holiday" is the wine festival. The women pick the ripe grapes, placing them carefully in wooden troughs and then they carry them to the wine presser who stamps around the barrel in his *botts* and presses out the precious grape juice. The festival is usually rounded out with dances and parties at which the girls are always beautiful and charming in their gay, colorful outfits.

About twenty years ago, while visiting a Hungarian farm, I was out in the field and saw an old woman of at least eighty walking between two plowing cows, helping to support the yoke. I walked up to her and asked, "Isn't this too much for an old lady?"

"Mister, we use these cows for plowing, and then at night we have to get our milk from them," she explained. "If the cows' shoulders hurt during the day, they give less milk, and the quality is not so good. I'm trying to lessen their work to protect the milk we expect tonight."

Thus farm life goes on in Hungary as it did 150 years ago. Even today, there is little machinery in that section of Hungary—practically everything is still done by hand.

The Hungarian peasant loves his pipe. On Sunday he



Left: (above) Margaret Island swimming pool in Budapest; (center) mechanically-induced waves soothe the bathers at the Budapest St. Gellert Hotel swimming pool; (below) The St. Stephen's Day procession in Budapest is viewed by thousands annually. Right: (above) Heuriger Wien in Grinzing, Vienna; (below) The Hungarian Parliament buildings and the Danube, seen from St. Gellert.

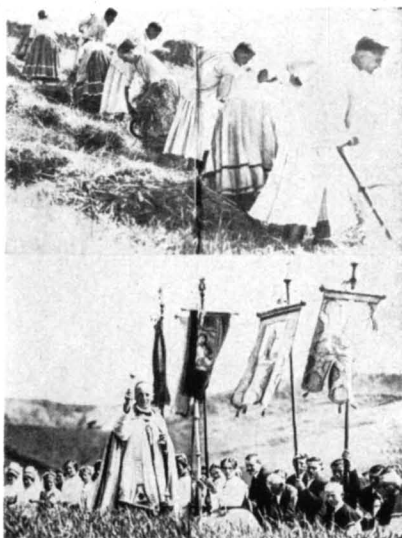

Left: (above) Hungarian peasant girls rise at 5 A. M. to harvest the grain; (below) Hungarian boy lifts yoke from cows' necks to ease their burden in plowing. The result: more milk. Right: (above) Men and women work together in the Hungarian grain fields; (below) An age-old custom: the priest blesses the fields for an abundant harvest.



Left: Hungarian peasant and pipe. Right: Hungarian girls in their peasant finery.

smokes a meerschaum with a long cherry stem, but during the week his pipe is made of ordinary plaster of Paris. Most peasants will very rarely be seen walking or going anywhere without a pipe. The typical peasant, a kindly type of gentleman, loves his shirt to be hand-embroidered and likes a fur collar on his coat. He's a hard worker and his farm and home are kept very neat and efficient.

While most of the houses in the country areas may not have sidewalks, roads and sanitation, the insides are im-



Above: Communist-held bridge crossing the Danube in Prague.
Below: The Budapest Chain Bridge over the Danube, in ruins in 1948.

Left: Prague's Medieval Bridge Tower, which emerged unscratched from the ravages of war. *Right:* A 1948 view of the Elizabeth Bridge in Budapest; completely demolished during World War II, it has since been restored.

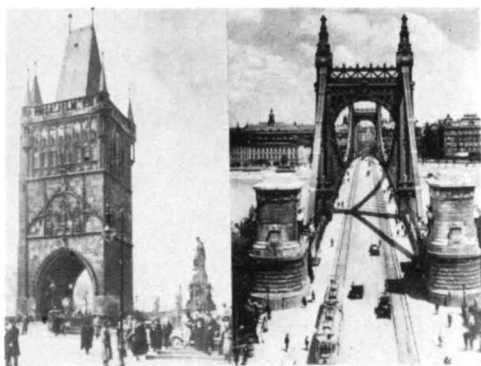



Left: (above) A view of St. Stephen's Church in Vienna; (below) Hungarian worshipers celebrate St. Stephen's Day. Right: (above) St. Stephen's Day celebration in the village of Mezokovesa; (below) The statue of the Hungarian novelist Jokai Mor in Budapest by Aloysius Strobl.

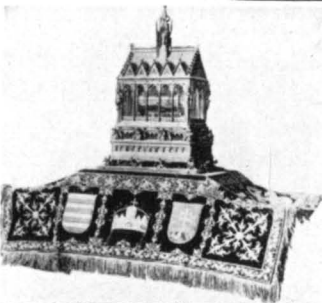

Left: (above) The holy right hand of St. Stephen was discovered intact when his tomb was opened on his canonization in 1083, symbolizing the sanctity of the ceremony for centuries since; (below) Cardinal Mindszenti, the highest official of the Hungarian Catholic Church, shown surrounded by the Sunday honor guard. Right: (above) Finland waterfront; (center) Typical Hungarian village scene; (below) Waterfront scene in Sweden.

maculate. Even though many houses have no flooring as we know it, they do have clay floors. The outsides are whitewashed; even the steps are whitewashed, often two or three times a year. Every home is sturdily fenced in. Altogether a hardy society making the best of circumstances. It is true that the Hungarian farmer does not have the many conveniences the American farmers as a rule enjoy, but I have seen many farms here in the United States that are not any more modern than those in Hungary.

It is taken for granted by those who have not had the good fortune to see Budapest that Hungary is essentially an agricultural country, but the city of Budapest—with its magnificent old buildings, parks, the beautiful Danube, museums, songs and its *cigany* (gypsy music)—was once the greatest city in Europe, the playground of nobility. From all parts of the world people came to revel in this most beautiful city, which incidentally once consisted of two distinct sections, Buda on one side of the river and Pest on the other.

Budapest boasts of its historic bridges over the Danube. When I was there in 1948 the Chain Bridge was still half under water; it had been bombed by American fliers. They were just beginning work on its reconstruction when I was visiting the city, and I understand it is now up again.

17. GERMANY AND FRANCE

EVERY YEAR for the past seven hundred years the Germans have held a fair in Leipzig; at least up to the time the Russians took over. The large machinery exhibit at each fair was my special interest and I tried to attend as many Leipzig fairs as possible. On my visit in 1934 I stood less than six feet from Herr Goebbels, who cut the ribbon at the entrance and officially opened the fair. His speech started with "*Deutschland uber alle die Welt!*" He yelled so loud that I could understand only parts of what he was saying. He told us that German skill, knowledge and industry led the world, that Germany would show the world, etc., etc.

It is obvious that since the last war German industry has come back to its own amazingly fast, and more perfect and precise in operations and products than ever before. Factories that were completely destroyed—bombed off the face of the earth—are now completely built up and more modern than before the war. They are working three shifts, supplying the entire world with all kinds of new equipment. Of course, this has been done mostly with American aid. German industry will control the world, at the rate it is being built up today. German machines are well built and less costly than American products. When I compare machine tools in general I don't know whether they copy ours or we copy theirs. The big difference is that the Germans can sell theirs at 30 to 35 per cent less than we can. This is due to many factors—German monetary values, more labor efficiency and more skilled labor, the latter being more industrious by nature and thus more productive. Eventually this can be a tremendous menace to our export business.

I think the Leipzig Fair is one of the greatest shows of its kind on earth. You see there people from all parts of the



Bon voyage, 1934. Mrs. Eisler and I sail for Europe on the *Europa*.

world, not only looking but also buying. Sleeping quarters are difficult to obtain during Fair Week. One can get accommodations only in private homes. Once we were sent to a lawyer's home through the Housing Commission for Foreign Travelers. We had a very nice room and we stayed there three or four days. Since Leipzig is in the Russian section, the Germans have now switched the machine tool fair to Essen. They have also built up an annual merchandise fair at Hanover, where important German products as well as many foreign products are being exhibited.

In 1934 on one of my trips to Germany, I was on a large German plane during a very severe snowstorm. I sat next to the German-American opera singer Mr. Hofman, whom I had met in New York and who was returning to Germany for a singing engagement. He told me that our passengers included the Nazi Führer Number Two, Himmler, and his pretty eighteen-year-old daughter. The storm was too bad to suit Herr Himmler, who ordered the plane down in München.

All of us went into the airport coffee shop for breakfast.



Left: At the Berlin Airport, August 1930; the plane was one of the first designed for long-distance flights. *Right:* In Leipzig, 1934.



Mr. Hofman asked me over to join Himmler and his daughter for breakfast, which I did. The conversation was very friendly. Himmler said to me in German, "*Herr Americaner, wie hat die Luftreise gefallen?*" Herr Himmler did not appear to be as we knew him by reputation. He was blond, of average size and very soft-spoken. While we sipped our coffee, he wanted to know how things were in the United States. I said, "*Sehr gut,*" and his reply was, "*Schön.*"

One evening in Leipzig I was having dinner with two German engineers who spoke English. A young lady came to our table and said, "Pardon me, gentlemen, you all speak English so you must be from the United States." She told me sadly that she had been trying to get a permit to enter the United States; her aunt in New York had sent her an affidavit, but she was poor and had only a struggling luncheonette in Coney Island, and her affidavit was of little help to the niece. The girl pleaded, "Can I ask one of you to please sponsor me and send me an affidavit?" She spoke six languages and very good English. When I returned home, I sent her an affidavit enabling her to enter the country. She got herself a very good

position in New York translating technical and medical books. About six or seven years ago I received a letter from her thanking me for sending the affidavit. She added, "Do not be afraid, I will never be a public charge. I am now a citizen and I married my boss." She is now engaged in publishing and translating foreign-language books.

Similar requests have been made to me while I was in Europe, and, all told, I have made out some thirty-five affidavits. I cannot remember any who came here who are not doing well.

The year 1934 was the only one in all my European traveling experience in which merchants would not accept American dollars. My wife was with me that year and one evening we visited a fine restaurant. Before the meal I went to exchange my dollars into German reichsmarks. The proprietor told me he did not want the American dollars because in a few more weeks they would have declined in value.

I asked, "What will I do? The banks are closed and I will not have the money to pay my bill."

The restaurant-owner said, "Herr Americaner, drink and eat all you can and when you get your money exchanged you can pay me, but only in DRM. But I cannot accept any American money because it may become valueless here overnight."

No place would accept American money. Of course, we had no difficulty at the banks; they raised no objections to changing American money into German marks.

In 1948 I attended the Essen Machine Fair in Germany. It was also impossible to get a hotel room there. One large hotel put the following questions to me:

"Are you on a military mission?"

"No."

"No rooms. Are you on a secret mission?"

"No."

"No rooms. Are you on a government mission?"

"No."

"No rooms."

I asked the hotel clerk what he would advise me to do. He told me to go to the station and ask for the Foreign Housing

Commission. I did, but they had nothing. Every place was filled, or as the Germans say, "*Alles besezt.*" They suggested I go to Wiesbaden, a resort; I surely would get a room there. I hired a taxi, drove about thirty-five miles and arrived there about 11 P.M. The lobby was filled with people waiting for rooms, so the cab driver suggested going ten more miles where there were several hotels. No luck there either. I invited the cab driver for a bite to eat. We had a hefty ham on rye and two bottles of Rudesheimer and then drove back to Essen. The cab driver left me off at the railroad station; there I was in the station with no place to sleep, and it was a Saturday, which made it doubly difficult.

In front of the depot was an American military police station, and I thought, "I'll try there." I walked into the MP office and told them my story. The officer in charge explained that Saturday was a very bad day even without a fair because on weekends the American soldiers from all over the neighborhood came to Stuttgart to see their *fräuleins* and every available room was filled; the man in uniform had first priority.

There was nothing left for me to do but go back to the station. I made myself comfortable, opened my collar, loosened my shoes, removed my coat and started to nap on the waiting room bench. I don't think that I was asleep more than twenty-five minutes when a policeman tapped me on the shoulder. "*Das ist ein Wartesahl hier und kein Schlafzimmer*" (This is a waiting room and not a sleeping room). He asked for my identification papers and I showed him my first-class return train ticket and my American passport. He told me I could sit in the waiting room but I could not use it as a hotel. After he left I went back to sleep. I awoke for the first call for breakfast at 6:00 A.M. and enjoyed a German breakfast of sausage, bread and coffee. The fair doors opened at 10 and I was there on time.

I left town without getting a hotel room. I was told if I wanted a room for next year to pay for it in advance. I was not the only one with this experience. In all, it was a very interesting experience; luckily I was alone and the inconveniences did not bother me very much.

I had another interesting hotel experience, this time in Berlin. I had been stopping at the same hotel in Berlin for twenty years. One year I had to leave quickly and left some clothing and laundry that had not yet been returned from the cleaners. I told the clerk, "Put it away. I will be back for it next year."

I did get back the next year, but all the clerks had new faces. I said, "I left a bundle of clothing here last year and I want a room."

The new clerk informed me, "We still have your laundry in storage, but we cannot reserve a room for you any more."

"Why not?" I asked. "What happened? What did I do?"

He replied with a smile, "Der Herr Führer has taken over the entire hotel with his staff of officers and no one else can live here any more."

I had seen the Führer there several times before he became a world figure and so popular with the German people. There was the day a bomb was placed in his car; my wife and I were in Berlin lined up on the sidewalk on Unter den Linden. Of course, everybody heiled the Führer and we did the same as the others. There was great excitement throughout Berlin that day when the bomb went off. Unter den Linden was blocked off and we were kept on the sidewalk for hours until the news came that nothing had happened to Hitler. He is supposed to have said to his aides: "*Gluck muss der Mensch haben*" (Man must be lucky).



Mitropa Flughafen, Templehof, a restaurant at Berlin Airport, 1940.

The Russian zone of Germany has many interesting monuments in memory of the Russian soldiers. One I remember

well in 1948 was erected in honor of fallen soldiers and has a statue of a Russian general on top. It is constantly guarded and most of the visitors would not venture closer than two or three hundred feet. I was advised by some Germans not to get too close because the Russian soldiers might grab me and take me into their sector in Berlin. The walls of the monument are covered with the names of Russian soldiers who fell during the siege of Berlin and the names of generals and officers can be read. This structure is a very impressive sight and in contrast, to the right, can be seen the Reichstag in ruins, as well as many of the surrounding buildings in the same bombed-out condition.

Though I was cautioned not to go near the Russian soldiers, I decided I would take a chance and view the monument at closer range. The guard looked normal enough, though he did not say a word.

I said in English, "Pardon me, I am an American engineer. Have you any objections if I look around?"

He replied, "No, go ahead," in fairly good English.



Left: (above) The Russian soldier guarding this Soviet monument in Berlin in 1948 declined my offer of a duplicate print of this photograph; (below) This Russian war memorial in Berlin separates the East and West Zones. Right: Anzinger-Hochhaus mit Planetarium, Hanover, Germany.

Then I asked, "Have you any objections if I have my photograph taken with you?"

"No, go ahead."

So the taxi-driver took a photograph and I asked the soldier if he would like to have a copy.

He said, "No," with a smile.

I asked him how he was and he told me, "Very good."

This ended my visit with him. I offered him a carton of Camels, which he accepted, and he gave me a nice smile and a snappy salute when I left. The Germans were very surprised that I had the "courage" to walk up to the soldier and chat with him.

✓ ✓

In 1936 I decided to take Mrs. Eisler and all the children to tour a bit of Europe. After a boat trip across the ocean to Germany, I went by air to Russia and my daughter Martha, who was eighteen at that time, drove the car all over Europe. It was a large new Buick I had brought from the States. They went to Belgrade by way of Paris, Zurich, Berlin, Prague, Vienna and Budapest. When I returned from Russia, I met them in Zurich. We were on our way to Belgrade to visit a



Above: "In a free country again," Basel, Switzerland, March 22, 1939. *Below:* Budapest seen from St. Gellert Mountain.

brother and when we got to the Serbian border I found we had forgotten some important papers that we left in the hotel in Budapest. We had traveled for eight hours, but we had to return for the papers. The next day we started out again. This time in Serbia we could hardly get on the small ferryboat to cross the river Tisza, our car was so long. We finally made it, almost half of the car leaning over the side of the boat. We finally got to my brother's, but the dust on the roads was so bad no one recognized us when we arrived. The insides of our trunks were so dusty that we did not recognize our own clothing. It was a job getting cleaned. After three days of visiting, we went through the same ordeal on the way back to Budapest.

A few days later we went on to Vienna and then after a little rest to Prague and on to Zurich. Finally, we saw Paris and Le Havre before returning home.

It was in France that we had the most fun. Here are some of the questions asked at the border when we arrived at the *douane revision*:

(1) How many tubes have you in your radio set? (I did not know, and that lasted about one hour.) Did you sell any tubes out of your radio set?

(2) What is the serial number of your engine and where is it? (We all looked for about one hour but could not find the location of the serial number or the number stamped on the engine.)

The greatest trouble we had was with the license plate. The "D" on it the French took to mean Deutschland. In fact, all over Europe everybody took us for Germans because of that license plate—which was not so good. Once, on the way to Le Havre, where the steamer docked, I took a wrong road. When I noticed the mistake and tried to turn back, about twenty feet ahead a cop came running and yelling, "*Vous êtes allemands, je vous arrête immédiatement!*" (You're Germans, I'll arrest you right away!) You can see from this the love the French have for the Germans. I explained that we were not Germans but Americans and that the "D" on the plate was only accidental. He said he was sorry about calling us Germans, and he saluted and told us to go ahead to Le

Havre by way of Rouen. The children had read about Joan of Arc and, of course, we had to stop there if for no other reason than that it was identified with their heroine. The children were so impressed by Rouen that we almost missed our steamer back to New Jersey. But when we finally arrived in Le Havre we still had several hours to wait; so we all went out shopping for canned goose livers, or *pâté de foie gras*, made in Strasbourg.

We all had a good time in Europe that trip.

✓ ✓

St. Stephen's Church in Vienna is one of the most famous Austrian churches. The Viennese always admired this church and have immortalized it in song. "*O Du Alter Stephen's Turm*" is one of the most famous. Most of the damage was done by the Nazis during the invasion. A Sunday pleasure was to sit on the rubble and admire the old church, even amid the ruins. The Turkish invaders also tried unsuccessfully to demolish it, as we learn from history.

Vienna is famous for its splendid restaurants, the most popular of which are in Grinzing. The new wine, called Heuringer, which is served in large bowls, is a favorite. The saying goes that if you have not been in Grinzing to sample the music and the Heuringer, you have not been in Vienna.

Looking at the bridge that crosses the Danube in Vienna, one doesn't know whether he is in Russia or Austria. When I was there the bridge was ornamented with pictures of Russian leaders, inscriptions and flags. This, of course, was only during the invasion. While Russian popularity was short-lived, it left its stamp.

✓ ✓

I took with me to France on the steamer *Rochambeau* complete incandescent lamp factory machinery I made to exhibit at the Foire de Lyon. Every machine demonstrated at the Foire was sold before the week ended to the Electra factory in Prague, where I also went to demonstrate. I also got quite a number of orders from France, Sweden, Italy and England.

Three years later, when I returned to Prague for a visit, I found all machines duplicated, the buyers having four or five where I had sold only one. Far from being embarrassed, they took pride in this accomplishment, since their cost of duplication was far below the American purchase price. After this, almost every European lamp manufacturer purchased a few machines and duplicated them to fill his requirements. The only way that I was able to overcome some of the competition was to keep one step ahead of them by improving the machine every year and adding new types as quickly as possible. This was the first demonstration of lamp machines anywhere in the world, and people from all parts of the globe came to see the lamp-making machinery. Orders poured in from everywhere.

1 1

Some years ago when we were all in Paris again, we hired a taxi and I told the driver, "Please take us to the Eiffel Tower." He looked at us without comprehending. I told him again, "Eiffel Tower," and the children all repeated the name for him, but the Parisian didn't seem to know what we wanted. After minutes of this, my wife suggested I write it

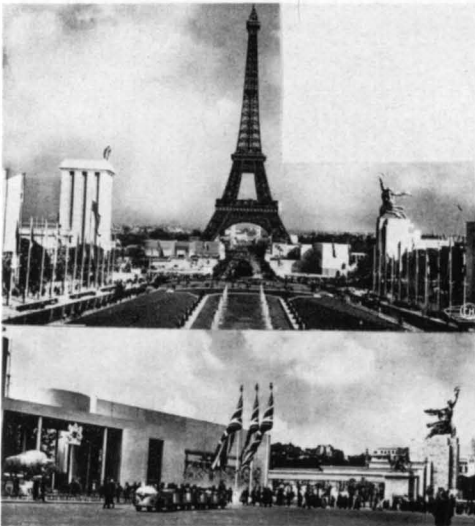

*Above: The Eiffel Tower.
Below: The Exhibition
Internationale, Paris, 1937.*

down on a piece of paper. I wrote Eiffel Tower and handed it to him, and he yelled out, "*Ah, Toor Doofel.*" Pronounced in French, it had an entirely different sound from the English version. We finally got there and eventually learned the French pronunciation, "*Toor Effel.*"



In 1930 I spent several days in Warsaw. I had to meet some people in the coffeehouse. Most of the customers were army officers with high collars, long sabers and exceptionally long shields on their military caps; in other words, overdressed, over-uniformed and over-sabered. Whenever an officer entered the crowded coffee house and looked around, civilians would get up so the officer could get a seat. All day long one could see fast-speeding uniformed army men with officers in riot cars. They had the population scared to death.

There was a lot of unrest. When I took the train out of Warsaw there were a number of riots at the station. I had to duck into a barber shop to avoid one.

I had been in Poland several times. I found there high-class hotels and good food in the French style. At the railway station I saw about 250 young Jewish boys getting ready to start a new life in Palestine. Not permitted to go to school for a higher education, there was nothing else they could do. Mothers, fathers, sisters, brothers, relatives came along to say good-by, crying and praying. Polish youngsters stood on the sidelines making all kinds of (not very pleasant) remarks.



Sooner or later, every European country arranges a fair to show foreign visitors its products. In Paris in 1937 was the Exposition Internationale, or World's Fair. One year I visited five fairs in five different countries. In 1949 I attended one in Zurich and about ten years ago I took in a very fine mechanical tool fair in Brussels.

When I was in Czechoslovakia in 1939 I attended a Radio Tube Manufacturing Program discussion with a number of Skoda engineers and the managers of their electronic division;

I was to supply them with engineering data and machines for their production schedule. The meeting was in full swing at the Skoda Works when, completely unannounced at about 10:30 A.M., a group of German generals and other high-ranking officers in uniform walked right through the room where the meeting was being held. Big boots thumped and large sabers rattled all around us as we sat there at the conference table. They were very polite to us as they walked by. They all smiled and saluted in the typically German military fashion. They did not stop, just looked around and then went to see the grounds and inspect the factory. The Czechs in the plant told me that no one knew anything about this intrusion, and as the meeting broke up then and there the engineers as one said: "Our country has been sold from under our feet."

And so it was. I walked out of the plant into the street; everyone was crying. The streetcars had stopped running and soon the streets were filled with people praying, singing, shouting—or just walking up and down the main street of Prague.

When I got to my hotel I was politely told that I must vacate my room—it was needed for the Führer and the German General Staff.

I went into the street again. People were still in tears, and one Czech told me, "Mr. American, we are finished. Our lives are in their hands!"

Hundreds of low-flying planes were now in the air. On one side of the street were supply wagons of every description. The Germans confiscated guns, ammunition, every weapon. It was so systematically organized that within two hours of the Germans' arrival military trucks were loaded as high as possible with every type of military equipment belonging to the Czechs. Hundreds of thousands of people lined the streets of Prague, completely disorganized and broken in spirit.

Later that same day I saw several hundred large trucks loaded with Czech factory-workers being taken away to concentration camps. The German spies had organized so carefully that all Czech works engineers, small manufacturers and members of organizations were listed with the German ad-

vance guard, and all who were not German sympathizers were arrested when the Germans came.

A day later Hitler was there in person. I listened to him as he spoke from a hotel balcony—the same hotel from which I was put out. He yelled so loudly from behind a one-and-a-half-inch-thick glass partition (to protect him) that I could not understand most of what he said. His German was bad, loud and excited. This was indeed the end of Czechoslovakia.

I had taken the night express for Prague from Budapest a few days earlier. During a stop about seventy-five miles from Prague members of the German advance guard in Nazi uniform boarded the train, shouting, "Everybody out, the train does not go to Prague!" It was about 3:30 A.M. I peeked out of the window of my locked berth. I saw men, women and children jump from the train, half-dressed, their bundles and suitcases thrown along the tracks. I stayed in my berth and pretended I did not understand German. A soldier yelled at me from the station, "*Herraus—herraus!*"

I kept repeating, "Praha—Praha, please. Praha, please."

The German soldier yelled, "Passport, passport!" I handed him my passport through the window, and he yelled to another soldier that I was an American and did not understand German. They did not make me get out. Finally the train pulled out of the station.

We arrived in Prague at about 7:30 A.M. The train was empty, except for me, and my luggage was still in my compartment. When I got into the city, I inquired, "What's going on?" No one seemed to know anything. That very morning—as I found out at the meeting—was to be the beginning of the end. Indeed, the Czech people were taken completely by surprise, never dreaming that such a thing could happen in their country. They were justly proud of their army and air corps equipped with the latest French military tools. It was a large, well-drilled, well-organized army, but it was completely routed in fifteen minutes and made absolutely ineffectual against the Germans. Not a single shot was fired by the Czech army one million strong, so complete was the sellout to the Germans.

The seizure of Czech guns and ammunition was the biggest

haul of military supplies in modern history. The German fifth column with its Czech coordinators had everything in perfect order, exactly according to blueprint. Even the German general staff was surprised that not a shot was fired—they expected some opposition.

Within three or four days beautiful Prague was emptied of everything of value, left full of misery. Hangings, killings, suicides and shooting were substituted for order. Leaders of every organization were hunted down and murdered by the Nazis.

No one was allowed on the streets after 9 P.M. without a military permit. Hundreds of people did not obey this order, and the jails were crowded with Czechs.

The Nazis tramped through the streets of Prague singing to music as they marched. Their slogan in song was "*Heute Prag, morgen die Welt*" (Today Prague, tomorrow the world).

I spoke to a few of them. Of one young fellow I asked, "What next?"

He answered, "God knows. We won't stop."



Left: (above) "You are entering Vienna..." (below) The Americans were greeted with wild enthusiasm when they marched into Prague, liberating the city for the second time. Above: The castle and National Theatre, Prague.

They were drunk with power—ready to conquer the world. Another soldier told me, "The world is ours." Within a few years it almost turned out that way. Had it not been for the United States, half the world would now be dominated by the Germans.

For me, it was all a terrible experience, one I shall never forget; imagine what it was to the Czech people. This was the end of the beautiful city of Prague and its liberal, kindly people—one of the best-loved, most democratic cities anywhere. But the Czech people were determined not to rest if it took five hundred years to regain their country from the oppressors.

I had my own troubles, too. I wanted to get out of Prague, but how was it to be done? There were no regular trains and exit visas were practically impossible to get. I went to the Czech General Staff Building which the Germans had taken over. In German, I told the officer on duty that I was an American engineer and that I was stranded in Prague. Could I get any help?

Durchlaßschein Nr. 644

Der ~~W~~ **E i s l e r** Charles Ing.
(Vorname, Familienname, Beruf)

aus (ständiger Wohnort, Straße, Hausnummer)

ist berechtigt, unter Vorlage des Passes (Paßes) 1))

Nr. 600040

ausgestellt von Washington

in der Zeit vom 20.3. 1939 bis zum 20.4. 1939

die Grenze zwischen dem Reichsgebiet und dem von der deutschen Wehrmacht besetzten tschechoslowakischen Staatsgebiet an den amtlich zugelassenen Grenzübergangsstellen zur Reise in das

besetzte tschechoslowakische Gebiet
Reichsgebiet)

und zurück zu überschreiten. Gen. Kdo. IV. A. K.

Prag, den 20.3. 1939

Für das Gen. Kdo.

Der ~~C~~ Gen. Stabes

Paßstelle I. A.

(Unterschrift)



1) Nichtzutreffendes weglassen.

2) Bei Reichsbürgern ist nur ein Paß, bei Ausländern ein Paß oder Paßes zulässig.

Exit visa issued by the Nazi chiefs in Prague in 1939.

He took me to an official who spoke to me in German. He said, "You speak beautiful German. How come?"

I told him that where I came from there were lots of Germans.

"Where is that?" he asked.

I told him, "Newark, New Jersey!"

We talked in friendly fashion for a few minutes. He told me he had relatives in New Jersey and some day he wanted to visit them. Finally he said, "It can be done."

He signed some papers and I received a card: *Durchlasschein Nr. 644*, otherwise known as an exit visa. With this in my wallet, I made my way to the American consul the next day, and was advised to take a special train made up of those fortunate people who also had these exit visas. From the window of the train to Paris all the roads as far as I could see had been blocked; no one could get in or out of Prague except the German soldiers and their Czech counterparts, the fifth-column "partners in crime."

18. *BEHIND THE IRON CURTAIN*

EAST GERMANY is behind the Iron Curtain, but United States citizens need no special passport or endorsement for travel in that satellite country. In the spring of 1956 I decided to go to Leipzig for the fair there.

I had to send my application for a visa not to the consulate of East Germany, but—shades of Frederick the Great—to the Soviet embassy in Washington. The visa was granted in a few days.

Arriving in Berlin, I had to report—you guessed it—to the Soviet consulate, in the special department set up for the Leipzig Fair. After my visa was okayed, I was finally permitted two hundred East German marks for my expenses. This is the way I got them. First, I had to buy West German marks, at the rate of four for a dollar. Then for each West German mark I received about four East German marks. Life is not simple for a world-traveler these days! Luckily there are no North or South German marks.

The next morning at 7:30 I took the train for Leipzig—my first journey behind the Iron Curtain. There was only one class on the train—wooden benches. My fellow passengers in the compartment were four men and a woman, typically German: the men had sandy hair, rather small bluish eyes, strong red necks, and no bellies. The woman, about forty, wore no makeup, but she was loudly dressed: red hat with a long pheasant feather, blue jacket and black skirt—all in the usual bad taste of middle-class German ladies. I noticed that the men were better dressed than in 1950, the last time I had been in Germany.

One of the men, about middle age, was an engineer with IGF, the world-famous German chemical factory. Only he and I were going to the fair; the others had different destinations.

They started eating as soon as the train left Berlin. (The train had no food or drinking services.) One of the men offered me a sandwich. I thanked him in German, explaining that I had just eaten. Since I had no accent, they must have wondered where I came from and when I lighted my usual big cigar, one of the men asked me. When I told them, "The United States," "Ah . . ." was the general murmur, and all faces turned toward me.

"You're a lucky man," sighed the woman. I was immediately under siege of their questions. What was the hourly wage of an American worker? What was the price of a man's suit? What was the price of an automobile, a baby carriage, a vacuum cleaner, a television set, a dozen eggs; what was the rent for a three-room apartment; what was the salary of a New York policeman; was it true the Americans were already manufacturing the cobalt bomb, that with atomic energy they could produce blackberries as big as nuts, that President Eisenhower was divorcing his wife for a red-haired Hollywood star?—and so on.

They compared American wages with their own, and figured they worked ten times as many hours for a pair of shoes or an article of clothing.

I was astonished at how freely they spoke about their situation. How did they know that I was not an *agent provocateur*?

"We don't dream about going to America, but we certainly would like to go over to West Germany," they said. When I asked why, the general answer was the low wages, the nine hours of hard work a day, and most of all the lack of personal security. Everybody was watched, nobody knew when the secret police might arrest him.

During the six hours' journey in the train, I got the impression that my fellow passengers were far from being devoted Communists. They told me anecdotes about the Russians and the Communists. One concerned the Jew who was awakened after midnight by the doorbell. "Who's that?"

"The postman," said a deep voice.

When he opened the door the man showed him his credentials—he was from the secret police.

"You applied for a visa to Palestine. Why do you want to leave the paradise of our People's Democracy?"

"Because," said the Jew, "in Palestine the postman does not come after midnight."

Another story was about some gypsy musicians who were jailed because of some remarks they made in public about the Communists. One of them, after he was released, met a fellow gypsy. "How did you fare in jail, comrade?"

"Fine! I was treated so politely—as if I were the only son of the great Stalin."

"No kidding!"

"I swear! And the food! For breakfast I got a whole roasted chicken, for lunch a whole roasted duck with a bottle of the finest Rhine wine, and for dinner a whole roasted turkey with a bottle of French champagne."

"I don't quite understand," said the other gypsy, "The cymbalist was released two weeks ago, and he said exactly the opposite."

"Yes," said the gypsy. "But he's *back* again!"

This type of story—with the same pattern—was making the rounds in all the satellite countries. But the woman with the long pheasant feather told me a true story of a man she knew who jumped his trial. A Communist detective pressured the man's wife, telling her, "You will come with me to the village where your husband's mother lives. He is probably hiding in his mother's house. You will introduce me to the old woman as Dr. Krammer, a lawyer, your husband's best friend, who wants to help him. Understand? If you don't play your role perfectly you'll see the consequences."

When they arrived at the house, the wife—pale and in a trembling voice—said, "*Mutter*, this gentleman is Dr. Krammer, a lawyer, Johann's best friend. He wants to help him. You can speak freely to him. Is Johann hiding here somewhere?"

"No!" said Frau Stolz. "When I read in the paper that Johann was at large, I waited for him day and night. I would have put him under my bed. And I wouldn't care—these dirty, lousy Communists, I tell you, Dr. Krammer, I have

only one wish: all these damned Communist detectives should drop dead!" The old lady was so sincere and determined and the scene so humorous that even the Communist detective laughed, and let the old *mutter* alone.

Then the conversation on the train turned to more serious topics. In the midst of a discussion on the merits of the Germans as compared to the Russians, the engineer stated, "Herr Eisler, when Poland was divided between the Germans and the Russians at the end of the eighteenth century, we Germans kept alive the Polish language and culture. We did not destroy the statue of Copernicus at Cracow University. But the Czarist Russians erased all traces of the Polish national emblems, statues, institutions, colleges, schools, everything. We German are highly civilized people compared to the Russians."

I did not venture into that argument. I thought of the millions of victims of the German gas chambers. Who was responsible? Who had done it: a whole nation, or only a group of human beasts who terrorized their own people as well as others? This is a question to be determined by future historians.

I looked out of the window as the train sped on past fields with no trace of the war as far as the eye could see. A light rain was falling and here and there on the horizon huge red flames and black smoke clouds spoke of the gigantic efforts



Dutch East India, 1949.

of the German working force. If there is any comparison favorable to the Germans it is this: The Germans are work-crazy. It has been my experience that an American worker puts half of the energy into an hour's work that the German does; at the same time the German wage is only a fourth of the average American wage. It means, financially speaking, that the results of German production are five times greater than those of comparable American production. We must face the fact that this ratio is a tremendous factor in the competition for the world market. German light tools, such as hammers, chisels, pliers, etc., excellent in quality and much cheaper than ours, have already invaded the world market—most notably in South America, but progressing noticeably on all fronts.

19. *UNHAPPY EXPERIENCES AND HAPPY ENDINGS*

EVERYONE expects a few close calls in life, and mine were lusus. Keep in mind that I'm here to tell them. They started in 1920, the first day I walked into my new factory. A monkey wrench dropped on my head from a steel girder above. It had been carelessly left up there and the vibration, along with perfect timing on my part, did the rest. Fortunately, only a bloody head and a few stitches were the result.

In 1930 fire broke out on the farm, and our attractive main house was burned to the ground. I was inside when the fire started, but got out in time and unharmed. But the new piano, refrigerator, furniture, my personal library—these were all destroyed, as was the house itself.

The year 1936 brought the inevitable automobile accident. A steering link bolt fell out, and the car, with no control on the wheels, swerved into a seventy-five-year-old elm tree. The wreck was a total one, but I was unscratched. Just lucky, I guess.

On my last extensive European business trip in 1948 I had made reservations in Prague well in advance for the return flight from Holland via KLM. But I was delayed in Rome and missed getting to Rotterdam for my scheduled return trip by less than one hour. The next day I read about my luck in the newspaper—the plane I had just missed had crashed and all forty-four aboard were killed.

And in 1950 my wife and I were on our way home from Miami. The plane was to pick up passengers in St. Petersburg but the pilot was unable to land because the landing gear could not be lowered. After long and unsuccessful tries at landing, he dumped all his gasoline, ordered the passengers to fasten their seat belts and took the plane in for a belly-slide. It sounded like a giant boiler shop as it landed. One

of its wings broke off, and the underpart of the plane was demolished. Not one of the sixty seats remained in place; but no one was seriously hurt, although everyone was badly shaken up.

But no matter how close the calls, so far I have managed to survive in this mechanical age, and with the aid of my wife's horseshoe I hope my good luck continues.



The Eisler New Jersey farm home reduced to ashes.

All that was left of the new Packard.

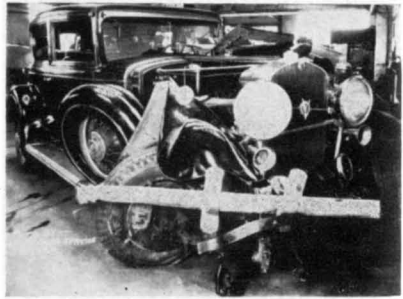

I happened to be in Paris in 1931 at the Hotel George v when some American "shark" must have recognized me. He proceeded to work a tricky scheme—simple but effective. He wired my office in Newark: *Mr. Eisler has purchased some rare French wines for \$1900; please send check to so-and-so.* My office paid out the required sum. Of course I never ordered any such wine from any French dealer, but my office could not know that, and so I got stuck for a nice sum. We did receive for this \$1900 about forty cases of all kinds of cheap Italian and French wines—total value about \$150. The wine was shipped from New York to Newark a few days after



Bellylanding in Jacksonville.

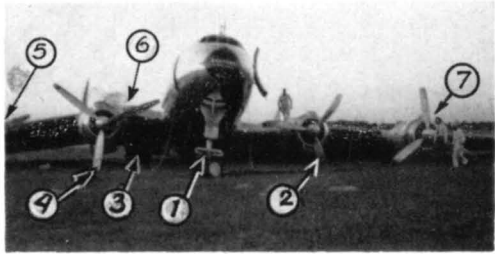

the check was received with a fictitious wine-dealer being named as the source. Once the cases arrived, however, it was taken for granted by my office that I had ordered them.

Not long after, when I was staying at the Hotel Imperial in Vienna, my office received a cable from that city: *Mr. Eisler has purchased some rare paintings; please send \$1500. Immediately.* Again a check was mailed; this time no paintings arrived. Then a week later another cable: *Eisler has purchased some oriental rugs in Paris; send check to so-and-so in New York.* My secretary became suspicious and went to New York with the \$1500 check and a private detective. When they arrived at the specified address, they found no one living there. The detective recognized the setup; it seems that other Newark businessmen had fallen into the same trap.

I saw no oriental rugs, no rare pictures. All I ended up with was some cheap wine. The faker must have had pity on me that one time; he at least let me have something for my money. It was a costly experience for the Eisler Company. The detective later told me of several others who were victims of the same clever fraud. At least I was not the only one—if that is any consolation.

In London in 1938 I received an invitation from a business acquaintance to see a show. During the intermission he suggested we have a drink in the bar, which was in the cellar of the theater. The bar was very small—I had to stand ten deep

to get my drink. We were pushed and crowded. My companion said, "Charlie, this is fun—were you ever pushed around by so many pretty ladies?"

So I told myself: This is really fun. I finally got my drink, over the shoulders of about five others.

During the commotion I felt a sort of push that impressed me as being manufactured. I thought, this is not an ordinary, friendly push; there's something special in this shove. When the next squeeze came the first thing I thought of was to check my wallet pocket. I found everything in order. Then I received another push and I said to myself, check again. But this time the push from these ladies and gentlemen was a fatal one. My wallet with \$980 in travelers' checks had disappeared.

I reported the theft the same night to the American Express Co. in London, and after my office in Newark supplied them with the check numbers, I was paid the full amount a couple of days later.

I had also been carrying about \$1000 in cash, but this was kept inside my coat—before I had left Newark I had a zipper and two extra buttons sewed on the pocket. When a man travels, sometimes the greatest precautions are not enough.

When I decided to purchase a home in 1929 I had to withdraw \$130,000 from the bank. I made my check out to the bank and the paying teller handed me the cash. But according to banking practice the bank always had to have on hand a certain percentage of assets in liquid cash, and my taking out \$130,000 placed the bank in a short position the next day. About ten of the directors came to me, begging that I put my money back for two or three weeks. But I had already made commitments and signed contracts with the builders, and I could not do so. As it turned out, this was my lucky day because two days later the President ordered all banks closed and all assets frozen.

During the late 1920s, banks gave extravagantly large loans on homes. Building and loan companies tried to compete with banks and gave still larger loans. Many loans were 75 to 100 per cent greater than the cost of the home at its

highest value. All this easy credit and overextension contributed the largest part to the crash of 1929.

The second and third mortgages on a great many homes were lost. Stocks of all kinds, especially bank stocks, dropped 75 per cent in 1929-30. The valuation of homes and apartment houses also went down considerably—about 50 per cent. Practically all investors in these mortgages were wiped out, as were quite a few of the banks and building and loan companies. Some depositors lost every cent they had saved for a lifetime.

I was more fortunate than many I know who lost everything they had. Although I lost more than \$250,000, I still managed to salvage something. Of course, I have had to wait many, many years to see a return of many of my stocks to their original purchase price. Some stocks which I purchased back in 1919 are still below their purchase price today, but I still hold them, although I don't think I'll ever see the day when they will reach the break-even point for me.

In 1930 I had sold a 49 per cent interest in my factory to a New York broker, Frank Bonner, for about \$750,000. With the money I already had it brought my total assets up over one million dollars. I had so much money I did not know what to do with it. I wanted to invest it wisely so that when I got on in years I would have everything I needed. I had worked hard for thirty-five years and I wanted to make sure that I didn't have to worry about the time when I couldn't work any more.

I went to a bank for advice. The bank president suggested that I invest about one half in bank stocks and the other half in common stocks of all kinds. As it turned out, the bank stock was the worst investment of all—since 1930 it has dropped about 75 per cent from its original price and in twenty-five years it has not recuperated. Although my other stocks went down in about the same proportion, the industrial stocks have come back quite a bit. My million dollars, which at one point was worth about \$250,000 if I had sold out at the time of greatest loss, has since started to approach its original value. Of course, much of the stock *was* sold at a great loss, since I had to raise cash to keep my factory

going. On looking back, it seems that the bank president did not know any more about what constituted a good investment than I did.

I still consider myself very lucky that I did not lose all my holdings; many lost everything in 1930, even after others had taken their beating in 1929. The year 1930 will be long remembered not only by myself but by many, many others. By 1931 it was not important what you had in 1929 before the crash, but how much you had left.

In 1921, at the outset of my business, I went to a large bank and told the president I wanted to borrow some money to expand. I had lots of orders but needed money to build the plant to fill the orders.

After a half-hour of questions, suggestions—everything except lending me the money—the banker said, “Young man” (I was thirty-six years old), “how much do you want?”

I told him I needed \$20,000 and that I was willing to assign everything I had to the bank.

He said, “My man, I think you really are too young for such a large amount of credit,” and he turned me down.

It was a big shock to me. I told my experience to a friend of mine who explained that I had no chance with such a large bank that played only with big industrialists. He did business with a small neighborhood bank and suggested that I go there with him; he would give me an introduction to the president, who would talk to me differently. We went to the small bank and I told my story to the president, Mr. Koos. I filled out papers and set forth my requirements and the purpose of the loan in a loan application. He put all this before the bank directors and a few days later Mr. Koos advised me that they would not go along for \$20,000 but would grant me a loan of \$10,000. I told him that this would be of no help to me because the builder wanted \$20,000 “quick as a flash.”

Mr. Koos then said, “I personally will guarantee your loan. I believe in young people and when a man is as aggressive as you, our bank should go along.”

I got my \$20,000, put up a new building and in one year I paid back the loan with interest. I am indebted to the president of this little bank for my rapid growth; it would prob-

today and I showed him this half-million dollar check. Of course, bankers are entitled to the complete protection of their loans, but in many cases they use very poor judgment, usually going by so-called book value only; they also should take into consideration the *brain* value of the small manufacturer. No small manufacturer has much book value when he starts in business and of course without book value the traditionally minded banker will usually not grant him a loan. Mr. Koos, on the other hand, had the experience of a small man; hence his action on the loan, which brought success. Many financial people underestimate the little man. Remember, 95 per cent of all industries are started by one man under circumstances similar to mine.

There are people who for some reason or another do not like the other fellow's accomplishments or success. What is the reason: the color of one's hair, the shape of the head, the style of the mustache, the curve of the nose, or just everything about one? There is always some reason for someone to begrudge another's success. If a man dies poor even his enemies will say: "That's too bad, he was such a nice fellow, he could have been more of a success but he did not know any better." But if a man accumulates a lot of money from his inventions or by being industrious, and spends his entire life working to gather this wealth, some people will call him a miser or say that his money was not made in an honest way—or that he was just lucky.

Some will say: "If I made as much money as he did I would have given plenty to charity, I would have helped people to a greater extent." I have known men who when they were poor would give everything away if they had it. After they accumulated wealth and success in life you couldn't get a penny for a postage stamp out of them.

In general, I would say that my success was due mainly to: first, my manufacturing such machinery and articles that the market really needs; second, making them better and more efficient than the other fellow; third, giving the customer more for his dollar than someone else. The only way to become a leader in industry and to make a name for yourself is to make something the country can use.

It seems that I had an enemy for thirty years. He used to walk by my beautiful home—a real castle I had—and when he looked upon my blooming garden it would make him sick. He would tell others: “Now look, here is a man who came to this country from Europe, lives in a castle fit for an English king, a mansion of eighteen rooms and seven baths, has the finest garden in the neighborhood, lives on the largest piece of land hereabouts, with servants and automobiles. Every time I go by the place it galls me to see how these fellows who come here from the other side can build up such estates and factories. What have they got that we haven’t?”

Apparently this fellow was influential enough to poison the minds of many of my friends—as well as many people in the industry, who also bore a grudge against me for thirty-five years. I was told by many business friends that he gave orders to the effect that anyone seen associating with me would be dealt with. When he’d meet me, this fellow would act quite civil in the presence of others, but the moment I was out of sight, the old feeling always got the best of him. He could not see why I deserved my success. As luck would have it, I was able to carry on very successfully in spite of him; I have outlived this fellow, as well as held my own against the companies that sued me for alleged patent infringements and continued to harbor the grudge through the years. I have worked along different lines—my motto in life is: Never begrudge the other fellow his accomplishments or his success in life. I always wanted to feel that I had no real enemies. I always stuck to the principle: Live and let live.

My advice to anyone fortunate enough to make a lot of money is: Just be yourself and don’t let it go to your head. Of course, money is made to be used, so use it wisely; invest it conservatively; give some to charity and provide for and educate your children as well as you can. Learn to live better, but always within your means. Don’t hoard money: keep some for a rainy day, but spend some too, because you cannot take any with you; they say it is unlawful to put money in your coffin, so use it while you have it.

If people know you have money, you will be offered all kinds of money-making propositions. Every investment

broker will be on your neck and you will get so many propositions you won't know what to do with them. They will try to make you president of companies; they will try to sell you stocks and bonds and lots and firms, and show you how to make money faster. But you must be strong. No one can make money for you faster than you can make it yourself in your own business. In all my experience I have never made money in any business but my own. I fell for a few fancy deals, and every time I invested in this manner I lost money.

Everybody will want a donation from you, but if you give a donation to everyone who makes a request you'll be broke yourself and asking for donations.

You can make a lot of money only if (1) you stick to your own business; and (2) you do the most important work yourself; the more of the important work you do yourself the more assured you will be of keeping the money that you have made. The minute you leave things to strangers they will find a way to get their hands on the money you earned with your own hard work.

I don't say that there are no good investments, but 90 per cent of all recommendations on how to make money are worthless.

I have always told Charlie, "If you want to live a little bit better and have more comforts than your neighbor, you have to work longer hours and harder. Investments, if you want them, should be in standard stocks or bonds. Keep away from notes; second mortgages and loans are not always paid back and, as a rule, they make bad friends. Once you lend money to a friend, say good-by to it and to him because you will not see him again."

Finally, if you have made money, don't hold it for the day of your funeral. If you can give your children and grandchildren gifts, do so while they are young enough to enjoy them and you can see them being enjoyed. It will give you a lot of enjoyment and satisfaction to hand out checks while you yourself can still sign them. Very often people of means will tell you: "I will not give a cent while I am living; they can have all I've got after my death." In the meantime the young folks are deprived of the pleasures and comforts of life that



Charles Eisler at the age of fifty, in 1934.

you can well afford to lavish on them but don't because evidently you want to be the richest man in the cemetery. Since you can't take it with you, my advice is to spend it while you are alive. One must acquire this feeling of "giving with pleasure." It has always made me extremely happy whenever I was able to give.

My father would often say that if every one of his nine children would give him two dollars weekly, when he was old he would be a rich man. As it turned out almost every one of his nine children looked to him for help all their lives, and Father never got a penny from eight of his children on whom he hoped to depend so much in his old age.



Ruth, Mrs. Eisler, Martha and Connie posed for this 1934 photograph as a surprise for my fiftieth birthday.

My father struggled all his life with a large family; schooling and clothing for nine children are no small problems in any land, let alone poor Hungary. He used to say, "I was born poor and my lot is to leave this world poor." And it seems that his children — with one exception — inherited

the eternal struggle to eke out a bare existence. I was successful in my life, and I let it be known to everyone in the Eisler clan. I have been contributing substantially to the Hungarian Eislers since 1905; as I became more successful my help became more generous. There was no question in my mind that money was more important to those who waited for my help than to me, since I was so prosperous. I have had the feeling that whatever I gave away, someone was sending back to me in the form of health, long life and happy memories. Already I shiver at the thought of what will happen to those who have depended on my help for generations for food, clothing, medicine and expenses—what will happen to them when I am gone? It seems to me that there is something wrong with the entire Eisler clan—their struggle for a bare existence is still going on. They inherited misery. Though they all work, almost all of them still depend heavily on me. They don't seem to be able to get ahead from one generation to the next. Their struggle seems hopeless—most of them don't expect anything from life except mere vegetation. I only hope I can continue my help for many years to come.



I have received many honors from various groups, some of whom my legal victory benefited indirectly and others who were more directly helped by either my patents or even more directly by my actual contributions.

One of the honors I am most proud of is a Doctor of Science degree which was presented to me by Bloomfield College in Bloomfield, New Jersey, in 1951. The rather flattering convocation speech delivered by the Rev. J. Charles McKirachan and the actual presentation of the degree were indeed thrilling moments in my life.

In 1950 Bloomfield College was 143 years old. (It was founded in 1807 as the Bloomfield Academy.) For fifty of those years Prof. John Dikovics had been teaching Hungarian, German, Latin and Greek there. I was approached by three officials from the school who felt that something should be done to show our appreciation for the fine job this teacher

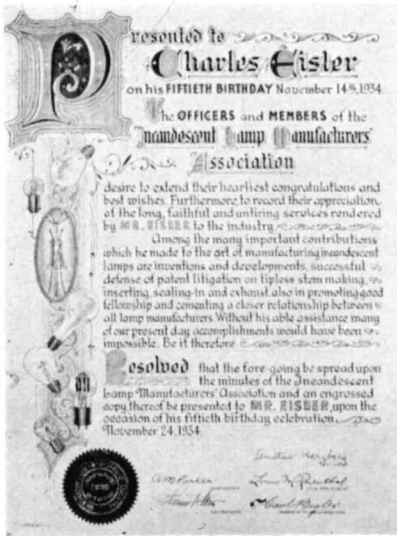

The ILMA observed Eisler's fiftieth birthday in 1934 with the presentation of this plaque.

My professional engineer's license, issued in 1942.

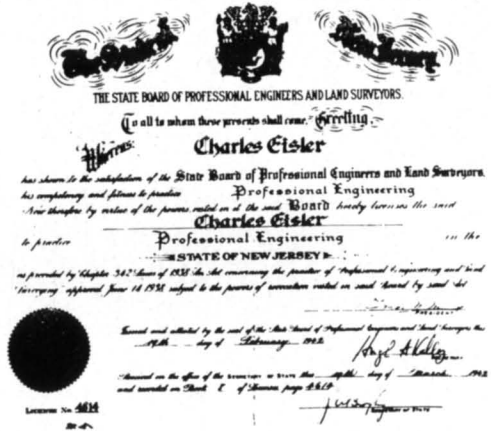

had been doing. I suggested that we reward him financially as well as with something he could "be remembered by." So, through the cooperation of Mrs. Eisler and her many friends, we raised a sizable purse which we presented to the old professor. And I purchased a building near the campus which was converted into a student recreation center and named Dikovics Hall. The bronze tablet in front of the hall com-



Left: (above) Charles Jr. congratulates his father on the conference of his doctor's degree; (below) Dr. J. Charles McKirachan reading the convocation as Charles Eiser stands at the right. Above: Recipients of doctor's degrees at the Bloomfield, New Jersey, ceremony (left to right): L. H. Clee, Governor A. E. Driscoll, Dr. Ralph J. Bunche, E. Haynes, Charles Eiser.

Bloomfield College and Seminary

By Authority of the Board of Directors Hereby Confers upon
Charles Eiser
 the degree of
Doctor of Science
Honoris Causa
 with all the rights, privileges and immunities thereunto appertaining.

Given under the seal of the Corporation at Bloomfield in the State of New Jersey, this twelfth day of January in the year of our Lord one thousand nine hundred and fifty-one.

It was now *Dr. Eiser*.

Walter L. Estellon
 President

Franklin S. Johnson
 Secretary



Federick Schweitzer
 President

Edward M. Carter
 Secretary

memorates Prof. Dikovics' fifty years of devoted service to Bloomfield College. This was the beginning of what we call the Hungarian Bloomfield Foundation, organized to help young students by giving them a congenial place in which to pass their hours after classes and on holidays or providing



Dikovics Hall of Bloomfield College and seminary

dorms for out-of-town students. The Eislers have installed a complete kitchen in addition to the recreation room and have tried to create a homey atmosphere for the boys and girls at the school. Mrs. Kovacs, the secretary of the Hall, has done a wonderful job as administrative assistant there.

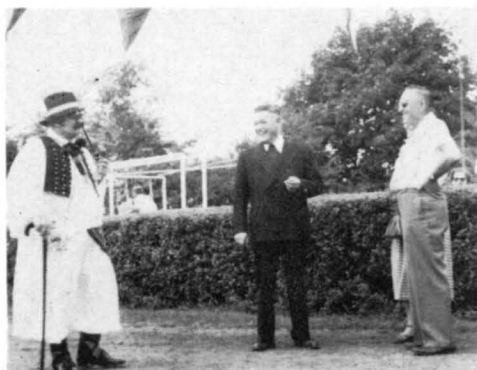

Few recognized me when I appeared at the annual picnic in 1942 in the dress of a Hungarian peasant (with facial disguise). The Rev. Gyozo Racz of the Passaic Hungarian Protestant Church is center.

To finish paying for Dikovics Hall, we have been conducting annual picnics on the Eisler farm; in addition, the Foundation has been fortunate in its friends and supporters who are donating to it.

1 1

In 1943, during the war, I was requested by a number of leading citizens of Hungarian ancestry to suggest a donation to the war effort from our national group. My suggestion that

we contribute ambulances was accepted and I was elected chairman to head the organization for collecting the money to purchase two ambulances. Workmen, businessmen and the professions donated what they could—from 25 cents up—and we soon were able to present the vehicles to the Army in a rather elaborate ceremony on the steps of Newark's City Hall. Acceptance was made in the name of the United States Army by Major Herbert W. J. Hargrave.

I want to express my thanks once again to all who participated in this patriotic achievement and helped make it the success it was; particularly to Joseph Nemeth, president of the Hungarian Culture Home of Newark, and the entire



Left: (above) Eisler burning the church mortgage at the Elizabeth Hungarian Presbyterian Church in 1953; the Rev. Károly Bogár is in *foreground* and the Rev. Andrew Kosa, of the New Brunswick Hungarian Presbyterian Church, is third from *left*; *(below)* The Rev. Joseph Rasky, of the Newark Presbyterian Church, blessing the two ambulances at the City Hall celebration, 1943, with Dr. Eisler, *left*. *Right: (above)* Celebrating the mortgage-burning event at the church; the Revs. Kosa and Victor Racz are left of Dr. Eisler; *(below)* Mezőkovesa peasant women, near Budapest, whose costumes were faithfully copied at the Newark ambulance ceremonies.



ON THE CITY HALL STEPS, NEWARK, NEW JERSEY, Sunday, July 25, 1943

Left: Chairman Eisler has just introduced Major Herbert Hargrave. Center: Newark ladies parade in Hungarian peasant costumes to commemorate the occasion. Right: Eisler making the ambulance presentation.



UNITED STATES TREASURY DEPARTMENT



\$2,408.00

In recognition of the patriotic and generous donations made to the United States, this relation is awarded to:

CHARLES EISLER, CHAIRMAN

Contributors to American-Hungarian Ambulance Fund of Newark and Its Vicinity,
Newark, New Jersey

Given under my hand and seal on

July 17, 1945

**Hungarian Group Boys
Ambulances for Army**

The Hungarian-American Ambulance Committee has raised funds for the purchase of two ambulances which will be presented to the Army at a U. S. Army Hospital at

Fort Meade. This was announced recently by the Commissioner of the Bureau of Internal Revenue, Charles E. Kester, Chairman of the United States Ambulance Fund. The funds were obtained from Newark factory employees, who contributed some ranging from \$5 to \$50. Kester said

Clay Morgan Jr.

Secretary of the Treasury

Left: Joseph D. Burkhard, representing the Hungarian-American press, expresses his appreciation. Center: Speakers at the ceremonies (left to right): Joseph D. Burkhard, Sarosy Albert, the Rev. Joseph Rasky, Major Herbert Hargrave, Judge Unterman, Mayor A. J. Cozzolino of Newark, Chairman Charles Eisler, George Beck, President Salkovich of the Hungarian Culture Society of Newark, Harry Brandstein. Right: A grateful government acknowledges its appreciation.

organization; to Bolzar Holzl and Louis Fisher, and many others who participated in this project.

/ /

Although a member of the American Society of Mechanical Engineers since 1917, I was greatly honored by being elected to life membership in 1952. Other honors I have received, and of which I am especially proud, include one

**THE AMERICAN SOCIETY OF
MECHANICAL ENGINEERS**

♦ 29 WEST THIRTY-NINTH STREET ♦ NEW YORK ♦

Dr. Charles Eisler, M. E.



ELECTED 1917

MEMBER

MEMBERSHIP CARD

C. E. Davies

SECRETARY

Life-membership golden card, American Society of Mechanical Engineers.

presented to me by the officers and members of the Incandescent Lamp Manufacturers' Association in 1945, on the twenty-fifth anniversary of the establishment of my lamp machinery firm. I quote from the plaque I received that happy night:

We consider him one of the most important pillars of our industry and without whom many of the lamp manufacturers, not only in this country but throughout the world, might not be in business today. The contributions of Charles Eisler to the incandescent lamp, radio tube, neon sign, electronic industries during the past thirty-three years have had far-reaching effects. The equipment originated, designed and built by him has stimulated progress and good will in the United States of America and in every other country where Eisler machines are used.

All these accomplishments were made possibly largely through one basic achievement in my career—my victorious patent fight which enabled me to continue making and sell-

cartel manufacturers. I have always permitted the free use of all my patents by all the independent manufacturers. In fact, there was a time when lamp-makers printed the words EISLER PATENT on their wrappers for protection against suits by the cartel.

I believe that the small businessman should operate free from restrictions; an unhampered industry means prosperity to the nation.

In recent years, a great many changes have been made by our government regarding patented inventions, but they came too late to help those in 1925 who were constantly threatened by the "octopus." The cartel prevailed in every part of the globe, putting the little fellows out of business in order to try to prevent competition and to control the industry completely. And it came very close to happening. Ironically, the cartel could have saved millions of dollars if it consented to a pool arrangement similar to that which now exists in the automobile industry. Instead of expensive lawsuits, a small royalty fee would have saved—and made—millions for these giants. Instead, the cartel lawyers picked on the very small, helpless manufacturer who was ready to fold up anyway; naturally this little fellow was lost before the suit started and of course he consented to a decree. These consent decrees closed down all the small manufacturers, until I organized the ILMA.

The final decree of January 7, 1952, saw the technical end of the long legal struggle, though the basic issues were decided in 1925, and but a few legal refinements remained to be drawn for these many years.

All the little fellows now belong to the ILMA—a sort of protective association. For the past twenty-five years they have not lost a suit. In fact, with the victory in the courts, every lamp-maker received proportional damages from the big companies. It is interesting to note that the courts ordered Corning Glass Co. to pay back something like \$3,000,000, to be divided among small manufacturers, including companies that had been out of business for fifteen years. And in General Electric's case the figure was even larger.

Many have been the contributions and developments in

INCANDESCENT LAMP MANUFACTURERS' ASSOCIATION

EXECUTIVE OFFICES
45 EAST 17TH STREET
NEW YORK 3, N. Y.

The Eisler Engineering Company
754 South 13th Street
Newark, New Jersey

August 10, 1953

Att: Doctor Charles Eisler

Dear Dr. Eisler:

In reviewing the operations of this association during the past 20 years we recall the many obstacles which confronted the small Incandescent Lamp Manufacturers who were operating prior to its inception.

One of their greatest difficulties was their inability to obtain certain necessary Lamp Making Machinery, especially, automatic Inserting, Stem and Sealing-in Machines by reason of certain patents covering these machines and which were not available to them. Up to the end of the first world war, they had to perform most operations either by hand or on slow speed manually operated machines. This made it very difficult for them to compete with their large competitors.

In the early 1920s, you succeeded in developing automatic Inserting, Stem, Sealing-in and Exhaust Machines which were made readily available to these small Lamp Manufacturers. This enabled them to gradually increase production, improve the quality of their products, and placed them in a better position to meet competition.

Therefore, on the 20th anniversary of the Incandescent Lamp Manufacturers Association we are prompted to thank you for your contributions, assistance and co-operation rendered by you to this branch of our industry.

Very truly yours,

INCANDESCENT LAMP MANUFACTURERS' ASSOCIATION

Louis Flein
Louis Flein, Secy.

L:MN

A further tribute from the ILMA in 1953, on the occasion of the twentieth anniversary of the organization's founding.

the industry by the small lamp-makers; they had given employment to thousands of people, and their part in the industry is by no means a small one. They have earned and justified their existence in the American economy.

20. THE "HAPPY CENTURY"

I WAS BORN about five hundred years ago. I am only seventy-five years old now, but in my life the world has changed so rapidly and fantastically that these seventy-five years witnessed more victories and tragedies of mankind than many centuries in the past.

In the cemetery of Time the tombstones of centuries sometimes slip slightly from their proper places. H. G. Wells said that the nineteenth century began in 1815 with the Congress of Vienna and ended in 1914 when World War I broke out. I was thirty years old then, therefore I am a witness of the last century. When I was born in 1884 the way of life in Hungary was similar to that of the fifteenth century, except for the train, the match and some other early inventions. In our house there was no electricity, no sewing machine, no bicycle, no typewriter, no telephone, no bathroom nor any of a hundred other things without which our modern time is unimaginable.

The automobile was not yet invented. Trains were so slow that a good-humored passenger hung a poster on one: "*While the train is going at full speed, please don't lean in!*" One out of ten of the sulphur matches flamed up, the others only smoked with a suffocating smell. Peasants still used flint and steel. Hot and cold running water? An old fisherman taught me how to get cold drinking water on a hot summer day: he stuck a two-yard-long reed into the marsh, and when I sucked it my mouth was filled with clean, cold water.

My parental home—every corner of it—lives vividly in my memory. There were flower beds, a vegetable garden, a small orchard, poultry coops in the back of the yard and a covered well next to the house with wheel and chain. There was a *saletti*, a summer house without walls, the eaves of which were



Charles Eisler at the age of seventy-two, in 1956.

decorated with "wind bells," small glass bells with feather tongues; in a breeze the many-colored little bells rang out a wonderful soft and dreamy music. There was a wooden shed in the back yard, for tools and for firewood and coal. The bake oven stood in the yard too.

My grandfather Eisler had the first kerosene lamp in his small village of Vistouk, a distinction which lent him considerable importance. This was in the 1820s, and he talked of it constantly during my boyhood. He was never entirely won over to electricity, for he felt in his heart that the kerosene lamp was superior.



Grandfather's kerosene lamp.

In the last century, even in wealthy people's homes the privy, a shabby wooden shed for some unknown reason always leaning a little to one side, stood in the back yard, possibly some distance from the house. Don't blame Hungary for that. Louis XIV, the Sun King of France, the most pompously dressed man in history, with Her Majesty the Queen and all his court, used the top of the royal palace for toilet. And I read in the diary of a Hungarian aristocrat that at the beginning of the nineteenth century elderly people and children, rather than go out on cold winter nights, used the corner of the room behind the beautiful baroque porcelain oven.

In my childhood the toilets, simple dugouts in the yard, were cleaned once a year by gypsies who specialized in this work. When they worked late on summer nights, all the windows were carefully closed. These gypsies were popularly known as the "smell artillery."

The wash pail is still the most important piece of household furniture in Hungary. Even in the city very few have bathtubs; people usually go to a public steam bath once

a week. In our family my mother used the staggered-shift system in order that each of the nine children be given his chance. It was a lot of fun, but a few years later our father built a regular bathhouse in the factory, with pumping hot and cold water. It was the talk of the neighborhood.



The wash pail.

It may be said that this way of life was utterly primitive. Still it was the Happy Century. The year when I was born, the fifty-nine-year-old Queen Victoria, the monarch of the greatest power in the world, was happily riding in Piccadilly in the open imperial coach, holding above her head her famous salmon-colored umbrella. Chester A. Arthur was the President of the United States, which had only fifty-five million inhabitants. Franz Joseph ruled the Austro-Hungarian monarchy—he and Queen Victoria sitting on their respective thrones for sixty years. There was peace and stability in the world.

I remember my teachers with gratitude and love. A man's character is basically formed in his childhood. Hungarian teachers in those days were very poorly paid. They were utterly poor, shabbily dressed, had very many children, but they never lost their sense of humor. One day our teacher—he had eleven children—told our class: "Tomorrow I'll give you a lesson in zoology. I'll speak about birds, especially about hens. Everyone has to bring along an egg." The next day he took home some thirty eggs.

"I cannot imagine a house without a fence," my father used to say. There was no house in Hungary without a fence, be it shabby or nicely shaped and painted—usually green. This habit came from Asia when the Ostiaks, the ancestors of the

Hungarians, had to defend their domesticated reindeer from the wolves and their women from the nomad Turks, Mongols and other hordes of the steppe.

The obscene words and drawings we chalked on the wooden fences of the houses before World War 1 disappeared and were replaced by more dreadful drawings: *hacken-kreuzes*, swastikas and arrow crosses, when the Nazis worked only underground. In those days I met the great playwright Ferenc Molnar in New York and asked him: "When do you intend to go back to Hungary?" And Molnar said: "I won't go back until instead of the swastikas children's obscene drawings will appear again on the fences." What was a great sin in my childhood had become a dream in another period of history.

A P P E N D I X

APPENDIX

I DO not wish to mislead my readers. The glass parts of the lamp are not among my inventions. Edison, Swan, and others made them during 1878-80. While I have added a few important improvements to Edison's inventions, many of the machines that manufacture the glass parts were first made by hand by others in the field.

In 1912 I produced the first practical, universal stem head; in 1919 the first stem-head tipless attachment; and

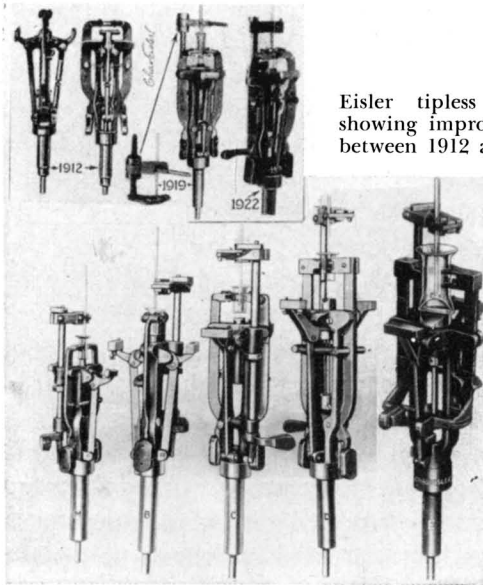

Eisler tipless stem heads, showing improvements made between 1912 and 1922.

also in 1919 the first standard tipless stem head (Patents Nos. 1,522,001 and 1,637,987).

STEM MACHINES

My first job in the lamp industry was to bring out a better, faster, and, of course, more convenient type of a stem head, so that the operator could achieve greater production with the least amount of effort. An original Eisler stem head of 1912 is today still in use everywhere. My first stem head was designed and made in Budapest, Hungary, long before I worked for Westinghouse in Bloomfield, New Jersey. It was patented here, however (No. 1,522,001). I don't believe there is a lamp or radio tube factory in the world that is not enjoying the benefits of this important Eisler invention, one so universal that lamp-makers cannot be without it.

A stem or foot is a component part of the lamp and, in principle, is practically the same for the radio tubes. Stems are tipless or not tipless. If not tipless, no exhaust tube is required inside the flare. A variety of stems are in use, depending on the type of tubes or lamps for which they are made. Stems are made from soft and hard glass tubing, depending on their use. The type of machine depends, first, on the particular production requirement and, second, on the type of stem. Stem machines can have a stationary or rotating stem head. In all cases I recommend the rotating stem head, but many stationary head machines are in use with good production and low shrinkage.

The stem depends on the stem head. Practically any type of stem can be made simply by changing the stem head. For all practical purposes the stem machine is always essentially the same. If different stems are required, the stem head must be changed accordingly.

The second problem I encountered at the Westinghouse plant was that the company had only hand-operated stem machines—the turret was pulled around the operator and the press was made by foot; this took up the largest part of the operator's time, and the production was thus limited. In Hungary, I had already converted many hand-operated machines to automatic, and I did the same here. Also in Hungary, we had better stem heads, making the loading of the

parts faster for the operator. So I made new heads for Westinghouse. My mission was to:

- (A) Make a new type of stem head entirely different from anything used before in the United States;
- (B) Design a special indexing Geneva-gear, so the operator did not have to pull or move the turret around (250 to 350 times per hour);
- (C) Make an automatic press by cam action, so the operator did not have to use her feet, and thus increase her production by using her hands for loading and unloading the work.

The operator used her hands and feet on a hand-operated stem machine prior to 1914. The stem press was on a slide. When the operator felt the glass was hot enough, she pushed

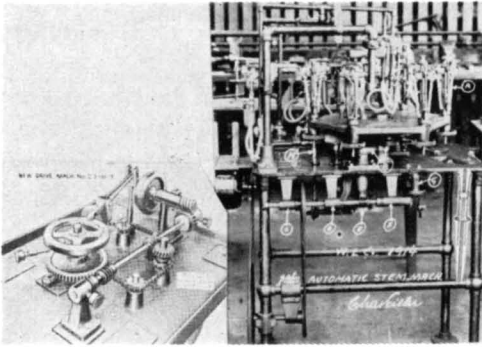

The first automatic stem machine, made at Westinghouse in 1914; the driving arrangements are shown left.

the slide in by hand over the glass and made the stem by pushing the slide in and out by foot; she locked and opened the machine, pulling the 4- to 5-turret spider by hand.

I was told this was the latest design here. In Hungary in 1912 this would have looked like a Hungarian "Rube Goldberg" device. I made a drawing of a Geneva and had a model made in Newark in the small Eisenlohr machine shop on Tenth Street. I also had all the parts made, and within three weeks the first indexing stem was completed. I was told to quickly make eight more, and in sixty days all eight stem machines were in operation.

Here was automatic motion, representing a gain of 50% in production. Now the operator could devote her entire time to loading and unloading the work, making her work

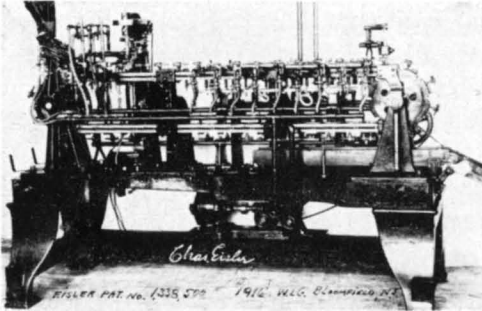

The first conveyor-type stem machine, designed by Eisler in 1916. The patent (No. 1,338,500) was assigned to Westinghouse in 1920.

less fatiguing and increasing her own production about 75%. After the first machine, I converted all Westinghouse hand-operated machines to automatics; there were no automatics in the plant before I joined the company.

After all the old hand-operated machines had been converted to automatic, I designed a still newer type of automatic machine which provided even higher production, and for thirty years was a standard machine in the industry. Every non-cartel lamp manufacturer who got hold of this machine was sued for infringement of the tipless patents by the cartel, who did not necessarily sue on the machine itself, but for contributory infringement and on the concept of the tipless method.

A stem machine for tipless stems was the first automatic stem machine I made for the independent lamp-makers. That was in 1919. Up to that time only hand-operated machines were available, and in most cases the lamp-makers made their own, on which the turret had to be turned by hand and the stem press was by foot. This 1919 machine increased production from 25 to 30%; the operator no longer was required to use her hands and feet to operate the machine. Her entire time was devoted to production—by indexing the turret and loading the machine with the lead wires and glass parts, the operator had to keep up speed. This was

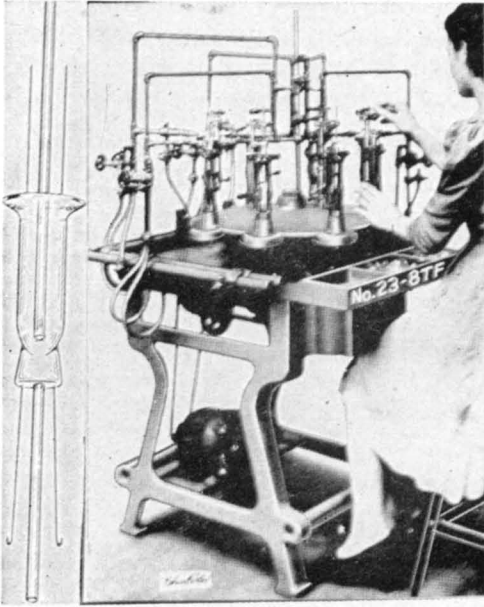

8-head fluorescent stem machine.

a big help to the independent lamp-makers. It was the start of automation. Save Electric Co. had the first eight machines in operation and Solex Lamp Co. in Montreal purchased several of the first group I made in 1920.

The Eisler Stem Head has been in use for over forty-five years and is considered by lamp, radio tube, and neon electrode makers the world over as the most practical and universal device in use.

The controversial, most fought-over patent in the history of the lamp and radio industry was the tipless stem patent (No. 1,701,541, 1924; No. 1,637,989, 1926; the latter, incidentally, is now used exclusively by neon sign-makers not only in the United States but all over the world). The incandescent lamp and radio tube manufacturers had no tipless patents of their own, with the exception of Herman Jaeger. But the Jaeger patent was not used by the lamp-makers and the cartel had its own Mitchell and White patents. Around 1924-26 the Japanese had to stop sending lamps to the United

States because they used the Mitchell and White stem patents (which employs a straight-exhaust tubing and a hole blown on the side of the stem for exhausting). But the Russians,

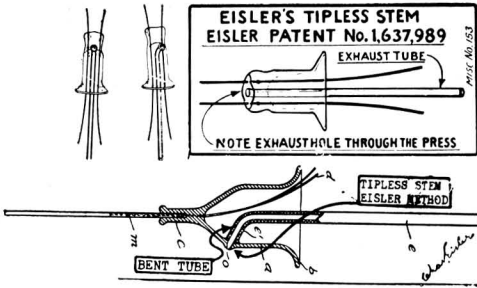

Two types of tipless stems patented by Eisler. Eisler's bent-tube exhaust method, successfully defended in court against the cartel, has been credited with saving the independent lamp-makers from ruin.

using the bent-tube method, sold vacuum lamps here through the Amtorg Trading Corp. when they learned that this was an Eisler and not the cartel method, and eventually the Japanese did likewise.

Herman Jaeger of New York City had been making incandescent carbon lamps for a number of years; then he told me that he was going to make a tipless lamp, just for the novelty of it. Simply because a lamp has or hasn't a tip doesn't improve it, but he thought that a lamp without a tip might boost his sales. In 1903 he introduced a tipless construction for incandescent carbon lamps. The only difference between the cartel method and Jaeger's was that he used a bent tube. Jaeger had practically no machinery and all his lamp construction was done by hand.

My 1912 stem machines could make the Jaeger bent-tube type of the cartel construction on the same machinery, without any difference in the setting of the fires. This in itself proved that no great changes were created by the Mitchell and White tipless patent in 1922; at any rate, it wasn't a revolutionary invention, because to the incandescent lamp industry tipless lamps were no novelty; old lamp-makers knew that tipless lamps were made before this 1922 patent. In fact, the first lamps were tipless in 1880-82.

Tipless lamps had been made in various European coun-

tries for some time—there was Andre in 1881, Alexander Burnstein in 1884, Swan in 1882 (to make them look like the other lamps on the market at the time, Swan put artificial tips on his lamps), Lane Fox in 1879, Nernst in 1900, F.

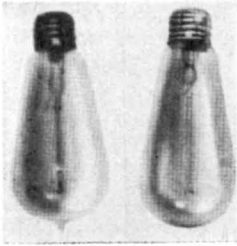

The tipless lamp, *right*, as contrasted with the tipped variety.

Knepper in 1915 in Berlin and Mullard in England. In Germany quite a number of manufacturers made their miniature lamps tipless. I had seen Germans, Hungarians and Czechs in 1910 and 1912 make tipless lamps by injecting an exhaust tube into the seal—a common practice in those countries at the time. Edison in 1880 made tipless lamps, and during 1878-84 a number of manufacturers here also made them.

Jaeger discontinued his tipless lamp, and it was not until 1918 that the cartel came out with a tipless lamp, known as the Mitchell and White construction. Since the cartel was the style-setter for most of the lamps in the United States, everyone now had to fall in line and manufacture tipless lamps, just as before only tip lamps were made because the cartel was making them. The cartel set the pace and at the same time tried to stop others from doing what could always be done.

Two American engineers, Louis Mitchell and Arthur White, in the employ of the cartel, thus introduced their method for making tipless lamps. The exhaust tube in most of the lamps up to this time was fused to the bulb from the outside by means of a tubulating machine. In the new method the exhaust tube was placed inside the stem tube and fused in the press with the leading-in wires on the stem machines. Before the glass cooled, air was forced into the exhaust tube and a hole blown through the soft glass directly

above the press. This method was also known as the Jaeger method. But, needless to say, the cartel insisted that only cartel members had the right to make tipless lamps.

In 1922, because of patent litigations by the cartel, I mechanized the old Jaeger hand-method of making tipless lamps in order to give the independent lamp companies a chance to continue their business by using the Jaeger bent-tube method with Eisler's machinery, without infringing on the cartel's patents. This Eisler method was adopted by all lamp manufacturers in the United States as well as in foreign countries. Even today large radio tube tipless stems are made with the bent-exhaust tube that I mechanized and patented.

During the period of the litigations I worked out two different tipless-lamp methods;

(1) One was the abandoned Jaeger patent which I mechanized. Everybody had free use of the Eisler tipless stem patent (No. 1,637,989, 1924), and the non-cartel manufacturers all used this Eisler patent—A, B, C, or D methods. Method D is still exclusively used by all neon sign-makers; it has been estimated that twenty million D-type Eisler-patented stems are being made annually.

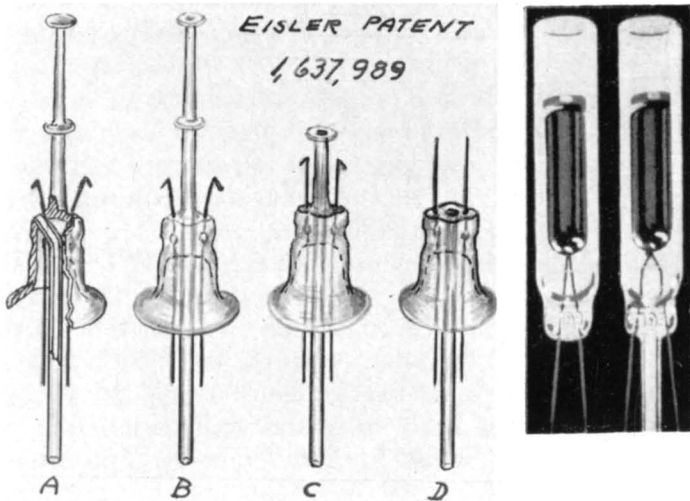

Several types of Eisler-patented stems.

(2) Since I didn't know what the practical outcome of the litigations would be, I was forced to develop an entirely different type of tipless stem, with the view of remaining in business and also keeping the independent lamp manufacturers alive. I had no immediate need for this patent; I was simply looking to the future. This 1925-26 patent worked out so well, however, that today not only the independent lamp manufacturers but also many of the large cartel companies are taking advantage of it. It can be adapted very quickly to the making of large radio tubes where 3- and 4-pillar stems are required. It is also in universal use today in the neon sign-making industry. Instead of permitting air to go through the exhaust tubing on the side (the Mitchell-White cartel patent), the method I developed in 1924 leaves an opening right through the center of the press. In order to keep the passage open while the glass is in plastic form, the exhaust tube is kept open by means of a pin, which is automatically removed before the glass is cool.

Since the most important cartel claim was "air being used" to blow out the exhaust hole in the stem, I conducted experiments to make tipless stems without using air pressure. The Save Electric Co. also worked along the same lines and assigned the Ray patent (No. 1,707,541) to me. With this method I proved that no air is necessary to blow out the hole in the tipless stem as long as the end of the exhaust tube is closed. There is sufficient pressure in the tube to blow a hole without using additional air pressure. (The cartel even claimed invention and patent of "air" to blow a hole in the stem, although air has been used by glass blowers for over 4500 years!)

SEALING-IN

Sealing-in consists of fusing together the stem inside of the bulb. Regardless of the type of lamp, radio tube, television tube, etc., as long as a bulb has a stem the sealing-in principle remains the same.

The sealing-in method has changed very little. It is practically the same today as it was originally practiced by the

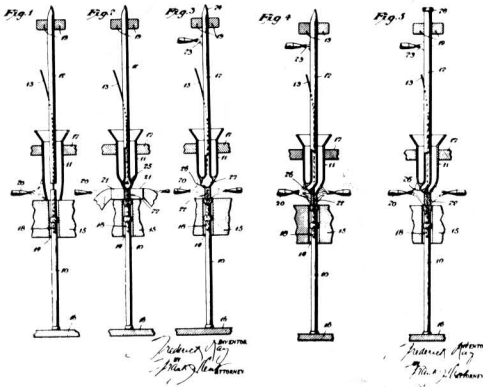

Tipless stems, originally patented by Frederick Ray (Patent No. 1,701,541), were assigned to and improved upon by Eisler.

earliest lamp-makers in all parts of the world around 1878, and is still in use wherever standard lamps are being made.

The first step in mechanized sealing-in was made by Thomas Edison's engineers in 1889. The bulb and stem were held horizontally in a holder and rotated in a flame, similar to previous hand-methods. This was the first important step in increasing production by mechanizing hand-operations.

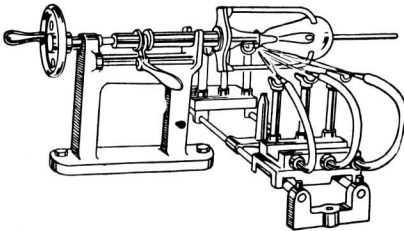

Edison constructed the first machine for sealing in carbon lamps.

A few years later, engineers converted the Edison horizontal working method to a vertical method, which brought about a complete change in lamp production. John Howell, working for the cartel in 1896, designed such a machine for vertical production. This method was adopted by lamp-makers all over the world, and is still in use today. Of course, many improvements have been made and many patents have been issued for vertical sealing-in, but to date no better funda-

mental method has been devised. The Howell sealing-in machine gave me the idea how to improve on it.

John Howell had been employed by GE for about forty-five years. I knew him very well, having met him in 1914 when I was employed as designing engineer for Westinghouse in Bloomfield. There is no question that this kind and soft-spoken expert had the first sealing-in machine on the market.

Howell made a 4-position sealing-in machine with rotating heads, rotating the stem and the bulb at the same time in a vertical position as they were sealed together—practically the same method used today. In 1914 Westinghouse had a number of these machines, but all were hand-operated. The operator had to pull the machine around from position to position, using hands or feet. I immediately got to work and mechanized these machines. Today this would be called automation. I placed Geneva motions on the machine, cams for moving the sealing rod up and down, and made an automatic machine out of it. Westinghouse had these machines supplied by GE, where Howell was in charge of equipment designing. Mr. Howell appreciated this innovation. He said to me, "Charlie, I take my hat off to you for doing such a great job."

I considered Mr. Howell a very clever machine designer. For his accomplishments and many inventions in the lamp industry, Rutgers University gave him a Doctor of Engineering degree, of which he was very proud. I always called him "Doctor" and he got a big kick out of this. When he passed away, GE lost a good man, one who had devoted a lifetime to designing and building machines to increase and improve production.

This was the process of sealing in carbon lamps as it was practiced at Westinghouse in 1910: Two operators tended each machine. While one operator pulled the neck and centered the stem, the other pulled the turret and loaded the machine for the next operation. The two operators had an average production of 125 to 150 pieces per hour.

Of course, mechanical equipment has been improved; but

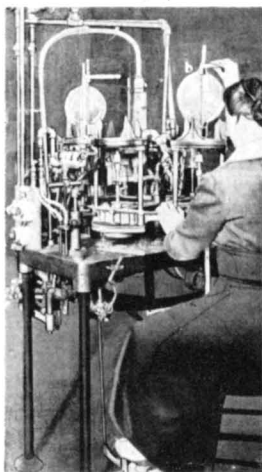

*Left: Sealing machine at Westinghouse in 1910.
Above: The sealing-in process as performed at
Westinghouse in 1910.*

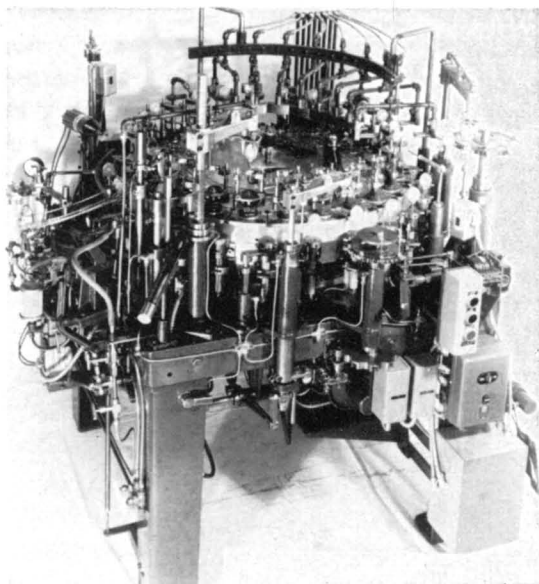

This Eisler automatic combination sealing-in and exhaust machine is representative of the most modern application of automation.

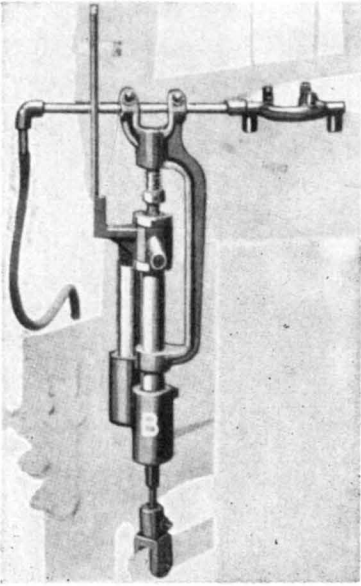

This Eisler tipping torch for automatic exhaust machine (Patent No. 1,936,426) was contested in litigation by the cartel.

even with the old equipment the operator would have made a better showing if she had the uniform material we have now; we did not then have the quality of glass and the uniform wall thickness of the bulb that we have today.



Making radio tubes in 1928 with Eisler automatic exhaust machines in the Tate factory in Irvington, New Jersey.

The material of fifty years ago would certainly be rejected today. It is so easy to criticize a product or machinery. Yet Howell had to start from scratch, whereas we had the Howell

machine to start with. I improved on this method, but the inspiration and idea came from Howell, who deserved tribute for introducing the first step in improved sealing-in machinery.

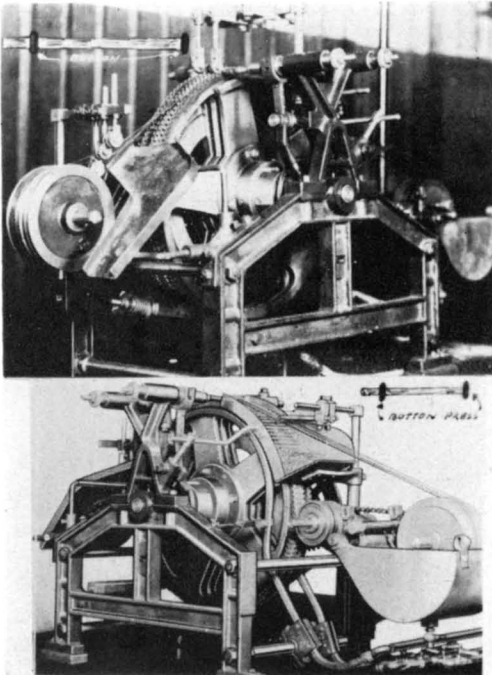

Two views of the Eisler automatic button press made at Westinghouse in 1915 (Patent No. 1,338,499) though designed by Eisler in Hungary in 1913. Production was 30,000 double buttons (filament supports) per day, as against the 3000 per day turned out by then-existing machines.

While the actual sealing-in operation has not changed very much since 1880, equipment automation has taken a tremendous forward step, and thus production has greatly increased. The same bulb-sealing method is in universal use for many types of lamps and can be described as follows:

The operator places the stem, shown in Step 1, into the holder of the sealing machine and follows up immediately with bulb 1, which is also placed in the holder above the stem. These two parts must be in perfect alignment. At Steps 2 and 3 the cullet has been burned off—this is accomplished by air rushing into the sealing rod; this air pressure separates the bulb from the cullet, and at the same time the lower part

of the chuck pulls the neck of the bulb, while the glass is still hot (this was done by hand for many years). Step 4 shows the completely sealed-in bulb as it comes off the machine.

Sealing-in machines are the same for lamps and radio tubes. Any lamp-maker can seal in radio tubes without additional radio experience.

The most important feature of the Eisler invention (Patent No. 1,655,050, 1925) is Step 3, better known as the automatic pull-down. This Eisler method is now used in every lamp- and radio-sealing operation.

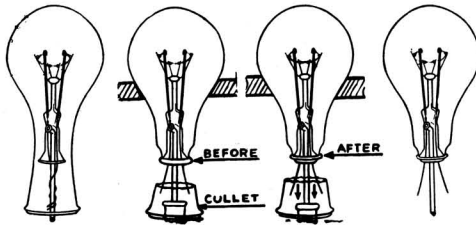

The Eisler automatic pull-down method of bulb-sealing increased productivity and minimized seal cracking. (Left to right): stem and bulb before sealing; seal before stretching neck, cullet cut off by fires; automatic stretching of seal; sealed-in lamp. (Cullet is removed automatically.)



The Eisler automatic neck-molding and bulb sealing-in machine. (Patent No. 2,418,763.)

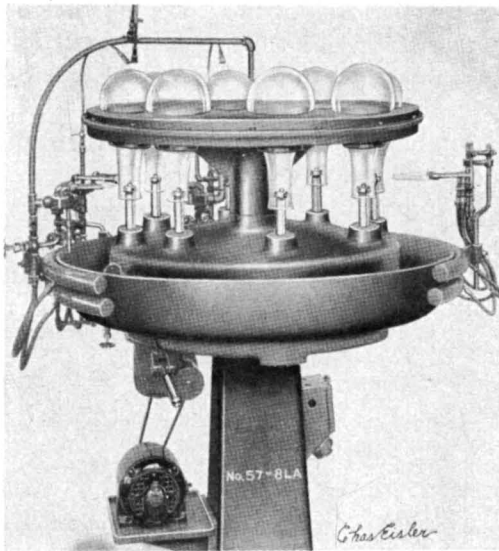

The Eisler automatic top and bottom drive 8-head sealing-in machine. (Patent No. 2,413,960.)

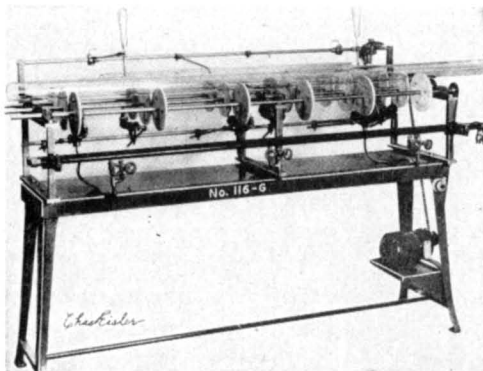

The Eisler glass tube-cracking-off machine. (Patent No. 2,410,931.)

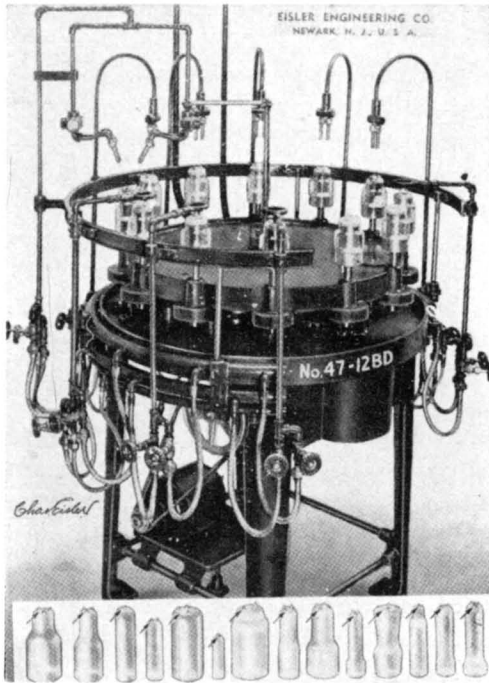

The Eisler bulb-piercing machine. (Patent No. 2,414,587.)

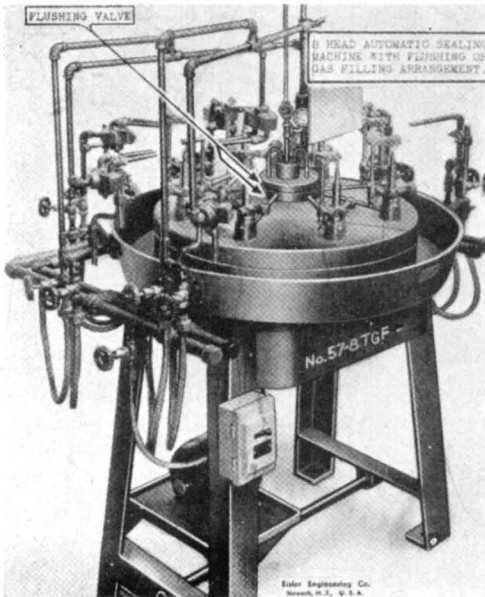

The Eisler automatic sealing machine with gas valve (shown at right) permits inert gas to enter bulb during sealing process, thus protecting parts from oxidation. (Patent No. 2,421,929.)

In 1919 I started on 8-position machines to make the air blowing off the seal an automatic operation. With one operation we were soon able to get 350 to 400 pieces per hour—a big step forward from two operators doing 125 pieces per hour. Production was made more uniform and greater, requiring less effort, less skill, and lower operating costs.

By 1925 the operator on an Eisler machine no longer had to pull the stem down by hand. Formerly, when the sealing machine had completed the job, the operator had to quickly remove the sealed-in lamp from the machine and pull the stem out from the bulb about 1/16 of an inch while it was still in a plastic stage. This pulling operation was very important but rarely uniform because of hand operation. The automatic pull on the Eisler machine greatly increased production, made the pulling uniform, and pre-

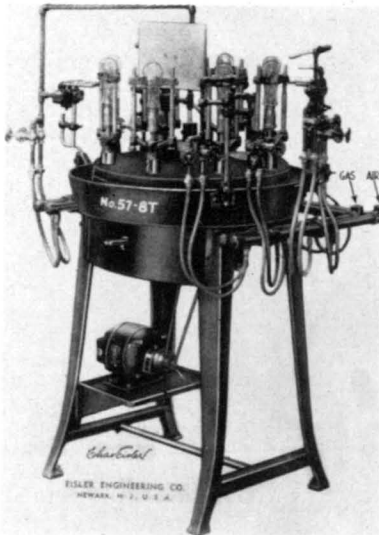

The first 8-head automatic sealing machine made for the independent lamp-makers featured ball pull-down clutch and auto indexing—the most popular machine of its kind in the world.

vented many cracked bulbs. And the pull was adjustable to the lamp or radio tube.

The exhaust tube ball pull-down arrangement I introduced is in universal use on all sealing machines, regardless of make. After so many years it is still the best and most

popular pull-down (it is also called "stretching the seal").

Sealing-in machines are made in a number of sizes, very often depending on the size of the bulb to be sealed in. These machines at the present time range from 1 to 24 heads. The adaptation of the machine depends entirely on the nature of the lamp to be manufactured. There are no fixed rules as to which sealing-in machine should be used. The best sealing machine is the one that gives the best production for the particular job, with the least shrinkage.

The sealing-in machine alone does not perform the sealing-in of the lamp and stem. It has taken many years of developmental work to determine the best metal and the type of sealing-in pin on which the flare is placed before the bulb is sealed in. Hundreds of shapes were tried before I found the best method and shape for a pin to make the proper seal that will prevent shelf-cracking.



Eisler-manufactured sealing-in pins and rods.

The nature of the metal for sealing pins depends on the type of lamp. For an ordinary lamp that requires gas or air, a brass or stainless steel sealing pin will last a long time. For hard glass, such as pirex or nonex, nickel or monel should

be used. There are, of course, other good heat-resisting metals. In other words, the metal that withstands the greatest heat and lasts the longest should be used in each case.

There are a number of other very important factors in dealing with sealing pins. A very slight air pressure must be used for blowing off the neck of the bulb. Therefore, the sealing pins must be so designed that the air coming through the rod must come out at the point where the blow-off takes

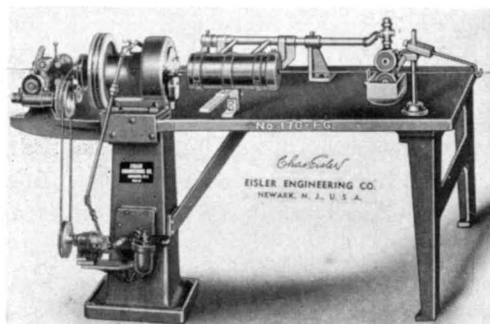

This tungsten wire-swaging machine with water circulating pump was a 1919 Eisler invention. The patent (No. 1,324,886) was assigned to Westinghouse.

place. There are no definite rules for the number of holes in the sealing pin, but very often from 3 to 5 holes are used. The Eisler machine is adaptable to sealing in all types of bulbs—incandescent lamps as well as radio tubes of many types and sizes.

In all, I have designed and greatly improved a large assortment of sealing-in machines. While the original design was not mine, I have contributed many important labor-saving devices. My most important improvements are the:

- (1) Neck pull-down steel ball arrangement;
- (2) Indexing: 8-12, 16, and 24 position;
- (3) Air blow-off for outlet by double seamless-tube arrangement (known as a sealing rod);
- (4) Gas valve added on machine to feed hydrogen gas into lamp while sealing, to prevent corrosion, carbonization, or discoloration of lamp parts.

The rapid growth of the industry required larger and faster machines for greater hourly production. In 1935 I developed a 12-position large-type sealing-in machine, with



The Eisler 12-position automatic bulb-sealing machine, 1935, making hand-pulling (as illustrated *below*) no longer necessary.

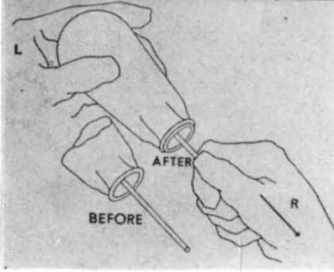

a different mechanical movement (Patent No. 2,063,235). This machine is made with a barrel-cam arrangement for faster indexing motion, whereas my first machines were designed and developed with Geneva-gear motions. Notwithstanding, the Geneva-gear motion I designed over fifty years ago is still in demand, and lamp machines are still being made with Geneva-gear motion.

This new type of machine is made up for 1500-watt lamps. It is also used to make large radio tubes and electric lamps of all kinds. The spider is much larger, and therefore the distance from each spindle is much greater. The operation of this machine is briefly described as follows:

The operator takes the stem in her left hand and puts it into the sealing rod; with her right hand she stamps the lamp and, when the stamping is completed, places the lamp right over the stem. As soon as she had loaded the bulb into proper

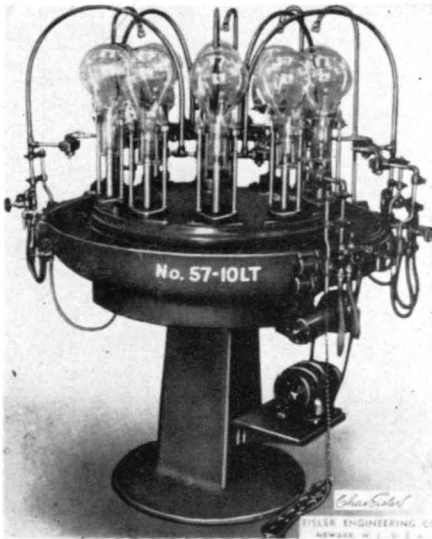

The Eisler 10-head automatic sealing machine.

position, the machine moves away from her, and she continues. In the meantime, while she is loading and unloading the machine, the fires on the machine complete the sealing in of the lamp; when the sealed-in lamp comes to the operator she removes the lamp and replaces it with another stem to be sealed in.

For larger lamps—500-, 750-, 100-watt—a 4-head sealing-in machine was made by Westinghouse in 1916. Fifty to seventy-five pieces per hour were considered a very good hourly production for one operator. The machine was hand-indexing. For the seal blow-off the operator used a foot-operated air valve. In 1925 I developed a 10-head automatic sealing-in machine for large bulbs up to 15,000 watts. One operator was able to seal in from 200 to 275 per hour. All the operator had to do was load bulb and stem and remove the finished bulb.

HAND AND AUTOMATIC INSERTING

Hand-inserting was the only method before 1929. To insert the hook or anchor in the glass buttons on the stem, the glass stem was held in the left hand and a sharp flame directed to the button; the operator picked up a "pigtail,"

or hook, with tweezers and forced it in the hot glass. This method was in use until 1914 by the cartel and until 1921 by the independent lamp-makers.

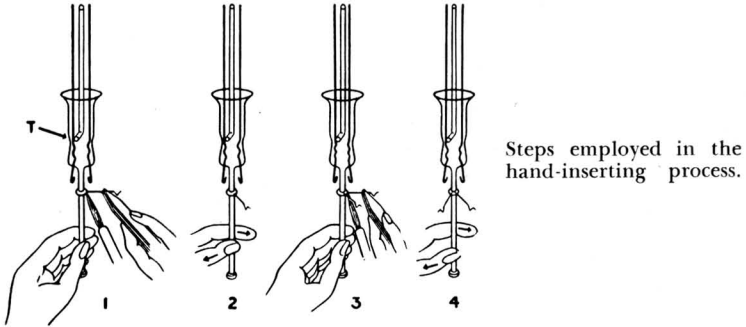

Many different types of inserting machines have been employed. The cartel had its pet method, and the independent had theirs. The earliest method was inserting by hand (the pigtail was made first and then inserted). In 1908, John Fagan, the General Electric plant manager, patented for the cartel a machine that at one time inserted all wires into a mold and then formed the glass over the wires. The method never worked satisfactorily; shrinkage was high and upkeep very costly. All in all, it was not what was wanted—but it *was* a cartel patent. Even if it was what the world needed, it was a very important tool in the cartel's hand, for it gave the cartel a machine just good enough to keep me and the independent lamp-makers in court on inserting-machine patent infringement. Though the cartel-patented machine was discontinued ten to fifteen years before the Eisler case, and I had at no time used the cartel patent, the cartel sued anyway.

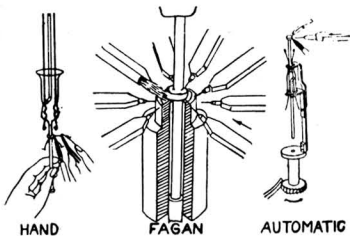

The automatic inserting method, as contrasted with the now-discarded Fagan machine and hand method.

On a typical 1921 hand-inserting machine the operator placed the stem in the machine and, by moving lever *L* back and forth, one wire was inserted in the glass button *B*. The operator made button *B* first by pressing on the hot glass rod with a flat tool. The wire supply came from spool *W*. Pigtails or hooks could be inserted. The stem turret held the glass

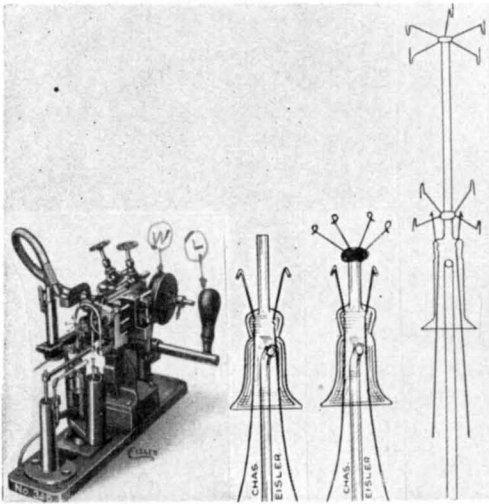

Hand-operated inserting machine, rendered obsolete by the Eisler method.

in the correct position while the button was being made and the wires inserted. When completed, it was removed by the operator.

Not a patented machine, this was the first type of inserting machine available to the independents. While it was an improvement over hand-inserting, a more automatic inserting machine followed this one a year later.

Until I developed an automatic inserting machine around 1922, the independents had to insert all wires by hand. Only the cartel had a workable automatic inserting machine, developed by Greiner. My machine was the first step in automation for the independent lamp-makers. The machine inserted and made the button at the rate of 350 to 400 per hour on a 5-wire insert, and was capable of inserting any number of pigtail wire supports (from 2 to 12) by simply having the gears changed.

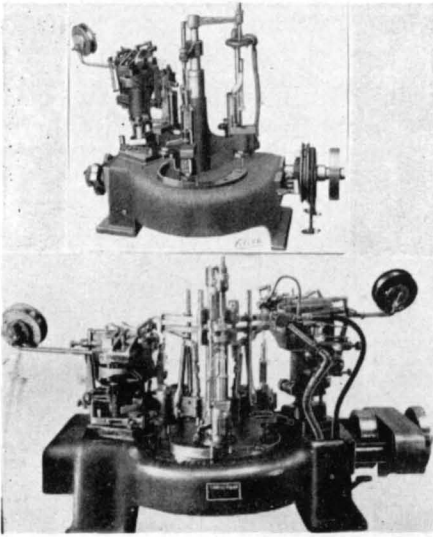

Above: Inserting machine for gas-filled lamps, 1921. *Below:* Inserting machine for vacuum lamps, 1923.

The operator places the stem in the machine at *S*; the button is made automatically. The wire comes from spool *W*. The wire-feeding and pigtail-making mechanism is *H*. The operator, by pressing lever *L*, sets the machine in motion, and a complete cycle inserts all wires in button *B*. Some turrets work automatically, some by hand.

COIL-WINDING METHODS

The 1913-18 Schmidt coil-winder was made in Berlin. The pitch of the coil depended on the threaded lead screw and change gears. (A bench lathe was adapted to this work in the United States when I came to Westinghouse in 1914.)

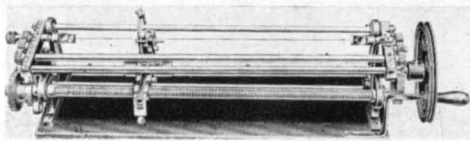

The Schmidt hand coil-winder.

The lead screw controlled the pitch of the coil. The mandrel rotated at low speed. Gaps were hand-controlled by stopping

the lathe long enough to pull the carriage on which the wire was mounted. The tungsten wire was heated by a gas flame.

I saw this operation at the Westinghouse plant in 1914 and I suggested a new design. I told Dr. Rem, my chief there, that I had made the original drawings of an automatic gap



Hand-operated bench lathe for making tungsten coils in 1914 at Westinghouse.

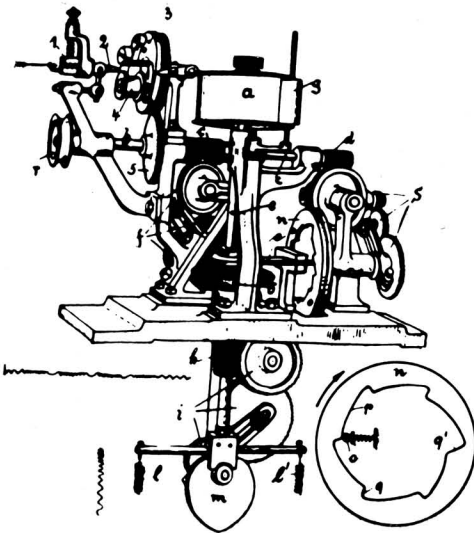

Original drawing of the Eisler automatic gap coil-winder—the first machine of its kind.

coil-winder that was capable of greater production with less labor.

The first tungsten coil filaments for gas-filled lamps were made in Vienna and in Budapest in 1912. They appeared on the European market before they were made commercially in the United States. I had the fortune of working as a machine-designing engineer in Budapest, and I had designed and made the first coil-winder for coiled-filament lamps in Europe in 1912. Two years later when I came back to the United States, this type of automatic machine was not yet heard of here.

Coil-winding before I made my automatic coil-winder was thus a slow and difficult process; it was impossible to make consistently perfect coils. Filament coil-making still was in its infancy; production was very slow, by hand, and not uniform. The best an operator could do was 35 to 50 coils per hour. Tungsten filament at that time was very hard and brittle, and gas heat was used, which did not sufficiently heat the tungsten to make lathe-winding practical.

The problem was placed in my hands, and I worked out an entirely new method of winding tungsten coils. I heated the wire by electricity at the point of winding, very close to the mandrel on which the wire was wound. The tungsten filament was first wound on a bobbin, which was placed on a face plate of the machine, and the mandrel was held by means of a clamping arrangement to the drum.

My machine was capable of making coils in a continuous length of 20 to 25 feet. The coiled wire was removed from the drum, cut apart, and then the mandrel or core was dissolved by means of acid. The mandrel wire was anywhere from .005 to .040" and the tungsten wire from .004 to .25", approximately. The machine was capable of making coils from 12 to 750 turns per inch and any number of turns between gaps. It was a universal machine, making coils from 75- to 1000-watts, with or without gaps. The different pitches were accomplished by change of gears.

I designed the first universal gap coil-winder in 1914 in the United States (Patent No. 1,338,498; assigned to Westing-

house). This winder completely revolutionized the coil-winding method and played an important role in the development

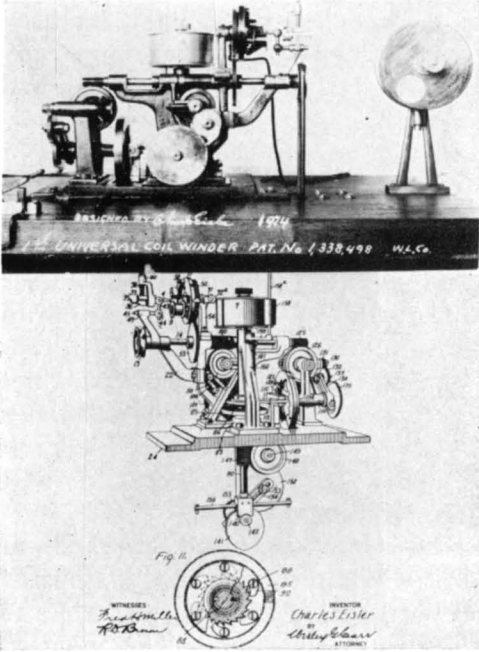

Above: The first universal gap coil-winder (Patent No. 1,338,498), designed by Eisler and assigned to Westinghouse in 1915.
Below: The original patent papers.

of the industry, both here and abroad. Conceived and developed in Ujpest, I perfected it while in Hungary in 1912, and patent was applied for here in 1914.

The machine proved very satisfactory and I produced three or four more, with some improvements on the first machine. It was in operation within three months of design, was duplicated many times, and redesigned in many other sizes for larger and different types of coils.

It was a very successful machine and became popular in the industry; there was no similar machine on the market, either in Hungary or in the United States. After fifty years, this method is still in use, and has not been outmoded. Of course, improvements have been made on it, but essentially it is the same machine I originally designed.

The early coil-winder was able to make coils smaller than

100-watt sizes, but in 1912 the smallest coiled gas-filled lamp was 100-watts and we did not feel that smaller coils would ever be required; not long after, however, coils as small as 25-watts were required—and were made on the same machine.

The machine made intermittent coils with legs and continuous coils. This fully automatic machine electrically

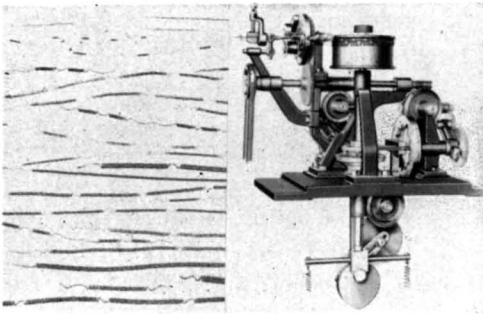

Left: Continuous coils, 25 to 500 watts. *Right:* The first universal tungsten gap-coiling machine made by Eisler in the United States in 1914 for Westinghouse. (Patent No. 1,338,498.) The original Eisler drawings made in Hungary in 1912 are on file.

heated the tungsten wire during the winding. Heat was controlled by an auto-transformer. It made any number of turns per inch, any number of turns between legs, in all sizes of tungsten coils, from 100- to 1000-watts—in all, 150 times more and better-spaced coils for gas-filled lamps.

I was always especially proud of the 1920 Eisler Gap Coil-Winding Machine (Patent No. 1,553,309). Although this machine was and is being duplicated in every country wherever electric lamps are made, and not many improvements have been made after fifty years, my organization still finds

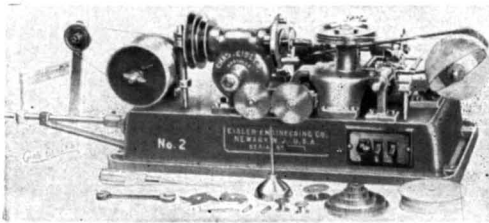

The Eisler gap coil-winder (Patent No. 1,553,309), an improvement on the 1912 Eisler design, was patented in 1920 and used by Max Ettinger at Save Electric Co. in 1919.

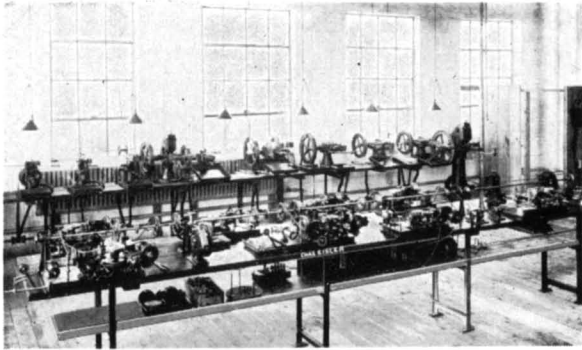

The first commercial coil-winders in 1920, when Eisler was the only coil supplier for the independent lamp industry.

a good market for it in the United States. Some of the most complicated radio tube coils are still being made on this Eisler machine. The most popular universal coil-winder on the market, it has the largest range of any machine made for the industry.

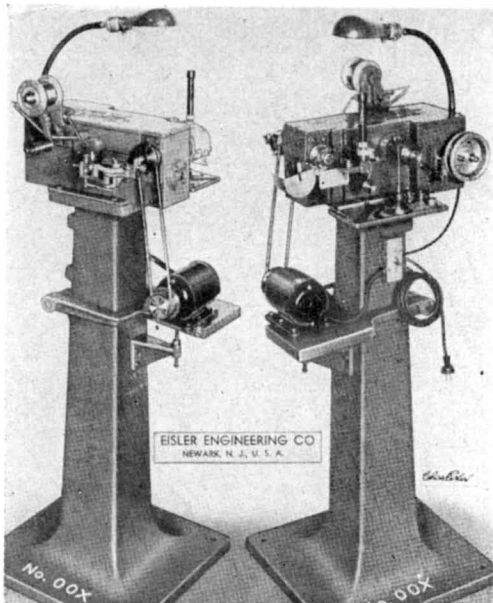

The Eisler high-speed coil-winder, produced in 1935.

The Eisler High-Speed Filament Coil-Winding Machine in 1935 (Patent No. 2,078,630) was designed in keeping with the times. Greater production had to be obtained from the coil-winding machine exclusively for continuous coils. To operate the machine at a high rate of speed, it had to be redesigned to operate the high-speed running parts in an oil bath. This necessitated incasing the parts and gears in a suitable housing to keep the oil from splashing out of the machine. In this way it was possible to rotate the spindle of the machine at 8000 rpm. The oil bath also made the parts last longer.

Large lamp requirements called for coil-winding machines for heavier coils. I introduced the first large tungsten gap coil-winding machine (Patent No. 1,553,309) in 1922.

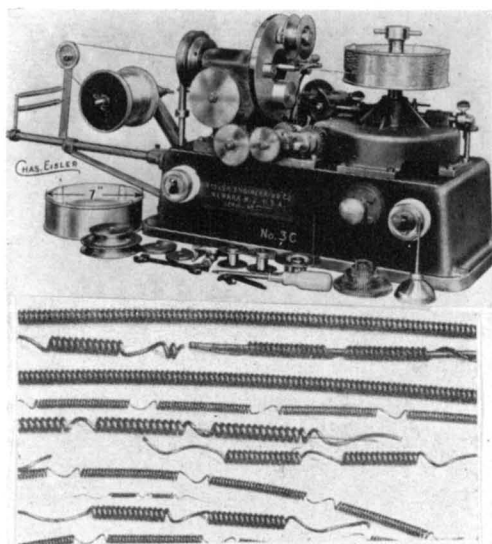

Above: The Eisler large gap coil-winding machine. (Patent No. 1,553,309.)
Below: Gap coils, 200 to 1500 watts.

The method is about the same as in all other coils, but the machine is capable of making all types of continuous and gap coils from 150- to 1500-watts. For more convenient operation, the transformer (for heating the wire for coiling) and the motor are mounted on one table.

It is always the best practice to have an individual table

for each coil-winder (including motor, transformer, and starter), regardless of size or type. This prevents any vibration being transferred to other machines, and is also more convenient for the operator.

COIL INSPECTION

An important operation is the inspection of the finished coils before they are made up in the lamp, since it is obvious that an imperfect coil (the smallest part of the lamp) will produce a bad lamp. My method is to place a large supply of coils on a glass plate; the image of the coils is enlarged 30 to 70 times and thrown on a screen. With optical lenses and microscope the operator can detect the imperfect coil and remove it from the bunch with a pair of tweezers.

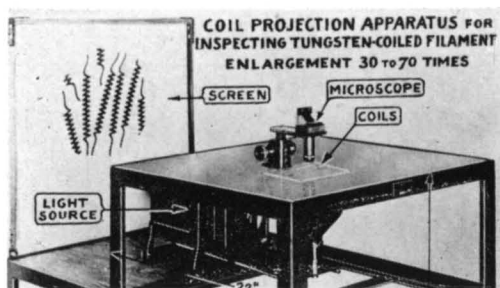

The Eisler method of coil inspection.

FLANGE MACHINES

John Howell introduced a machine for flaring the stem tube in 1898. This machine consisted of two rotating chucks arranged horizontally, one above the other. Short pieces of glass tubing were placed in the chucks, while the heat was directed to the upper chuck. The operator removed the finished products from the bottom chuck. The method is practically the same today when gas and air pressure is used to heat the glass, and produces more and better flares with less skill, as well as a more uniform product.

Hand-operated flange machines were adopted in 1910-14 as the standard type of machine, one vital to the lamp industry. A short length of glass tubing is cut from a longer piece. The operator places the end of the glass tubing in a



Hand-operated 2-head flange machine as used by Westinghouse in 1914.

self-opening chuck, then heats the end of the glass, and with a hand tool makes a flange on the end of the tubing.

With the old method the operator was able to make 100 to 150 flanges per hour. On the machine I had designed in Hungary two years earlier one operator produced 1850 per hour. I told Dr. Rem I could design such a machine for Westinghouse; it would increase production tenfold, with one operator attending three machines. The machine would also produce a greater uniformity of product, making all parts more accurately, which was impossible to do by hand. It became the fastest machine on the market.

I later had to prove in court to the cartel lawyers that I first designed this machine in Hungary long before I joined Westinghouse in the United States.

This high-speed flange machine was made and patented for Westinghouse in 1914. It has almost outlived its usefulness today because a more modern method, the hot-cut process, has been developed. However, many of these early machines are still in operation all over the world. Practically all factories not in the cartel used this machine at one time or another for twenty-five years with good results.

Flare annealers can be attached to any machine, hand-

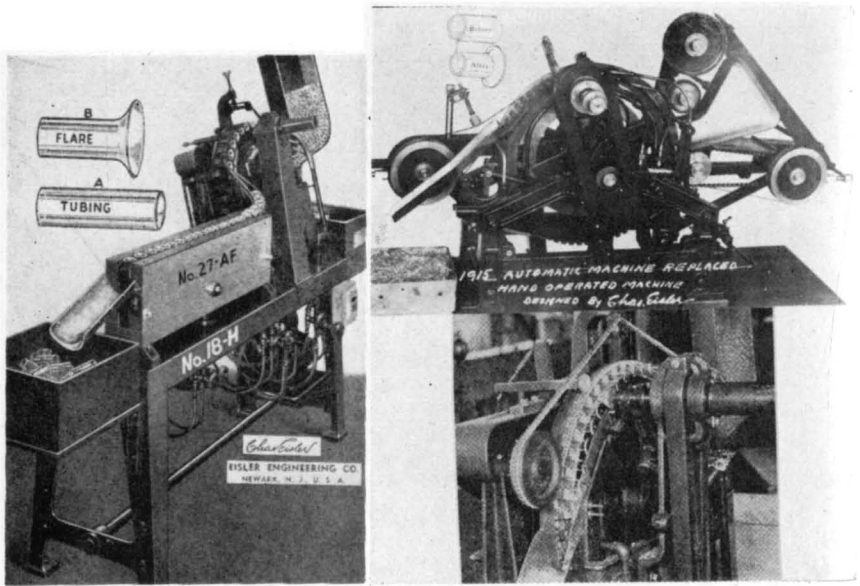

Left: The Eisler automatic flange machine, with a view of the flare and tubing. *Right:* The Eisler automatic flange machine (*below* at close range), designed by Eisler in Hungary as the first of its kind and made by Eisler for Westinghouse in 1915. (Patent No. 1,635,316.) Its outstanding feature was the perpetual chain drive for turning the glass tubing.

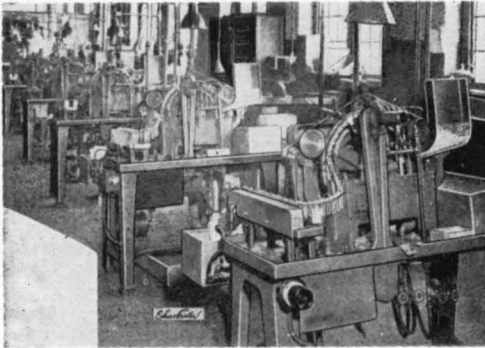

A battery of Eisler flare machines in use at the Wabash Appliance Corp. in 1928.

operated or automatic. An endless chain moving in the opposite direction distributes the flares over the graduated gas heat and rolls them into the hopper.

The Wabash Appliance Corp. as well as many other lead-

ers (producing 100,000 to 120,000 flares daily with very good results) have adopted it as a standard flare machine.

Like all inventors, I always made my own tests. When the trial run came up to my expectations, I called my lamp manufacturers to see the machines, and practically every factory purchased at least one. At the demonstration in 1928, Mr. Adler of Wabash Corp. said to me: "Eisler, I will use one dozen. This is so far the best and fastest flare machine I have seen." The Wabash plant manager, Otto Fohl, and chief mechanical man, Manganello, were both great boosters of Eisler machines. Adler had fourteen Eisler Flare Machines when he sold his company to Sylvania for four million dollars.

My improved flare machine in 1925 (Patent No. 1,635,316) had added features for higher production, and a good demand was created for it. The machine was the highest-producing device for this type of work, was very favorably received in many foreign countries, and was the leader in the industry.

The cut-glass tubing was placed in the hopper and rolled out of the chute completely flared and annealed. Production was about 2000 per hour, with one operator able to handle several machines. There are still many of these machines in daily operation, though the modern hot-cut machine has taken its place. With the hot-cut flare machine the tubing does not have to be cut in a separate operation. The flare tubes are burnished and annealed to prevent cracking. The flares rotate while being annealed in a gas-heated oven. The machines are adaptable for miniature vacuum and gas-filled incandescent lamps and radio tubes.

Constant improvements on this flare machine have made it the fastest machine in the independent lamp industry.

TURRET ATTACHMENTS

In 1916 I developed and patented a turret attachment (Patent No. 1,209,650) which greatly increased the productivity and versatility of lathe operation. The ordinary lathe or drill press, outfitted with this attachment, can perform operations similar to those of a turret lathe. One year later,

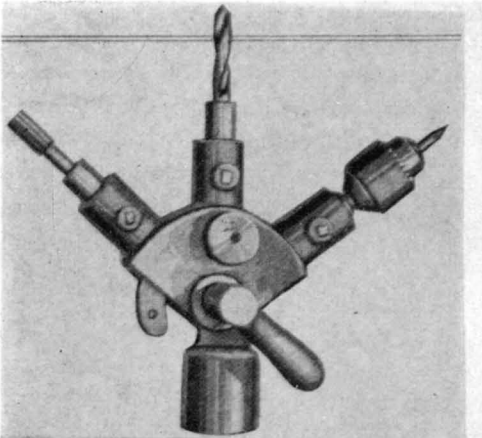

The Eisler turret attachment for engine lathes (Patent No. 1,209,650), designed in 1916 to handle drill-jig and die brushings, screws, studs and nuts, and used for recessing holes of various kinds.

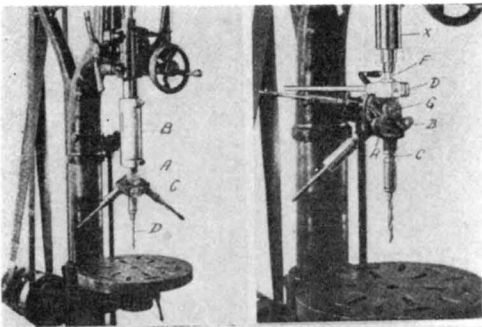
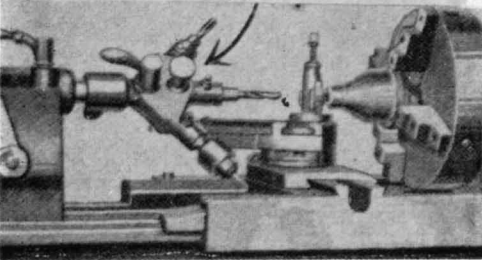

Above: Eisler vertical drilling turret attachments (Patent No. 1,209,650) in operation. *Below:* The attachments in various sizes.

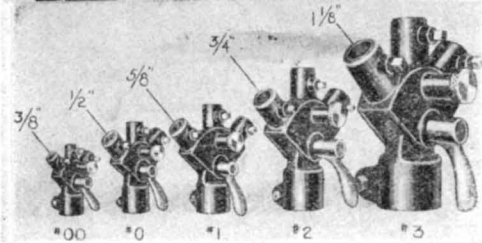

in 1917, I perfected and patented an adjustable turret head for lathes (Patent No. 1,246,250) which made it possible for the drill press to drill two or more holes as quickly and inexpensively as it had formerly drilled one, and which permitted a wide variation in the center distance of the holes. Designed for the manufacture of interchangeable parts, these innovations caught the attention of the *Iron Age*, and were featured in a November 30, 1916 article of that magazine.

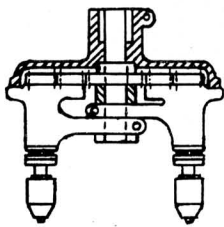

OPEN

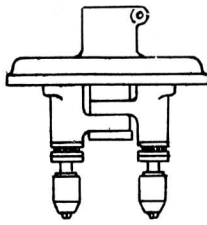

CLOSED

The Eisler adjustable drill head (Patent No. 1,246,250) shown in open and closed positions.

While both of these inventions were innovationary, there being nothing similar on the market at the time, my job at Westinghouse made it difficult for me to find the time satisfactorily to manufacture and market them. Moreover, they were, as it developed, about forty years ahead of their time. We have today a multiplicity of just such labor-saving devices, but in 1916 the demand for such tools was not vast. However, the response to and need for them in recent years has been gratifyingly widespread.

SPOT WELDERS

Spot welders have been in general use for over thirty-eight years. I recognized the need for improving the efficiency and scope of those in use at the time, and in 1932 I patented an automatic motor-driven spot welder with adjustable welding horns and automatic speed changes (Patent No. 2,006,544). Spot welders of many types and sizes have since displayed an increased productivity and manageability.

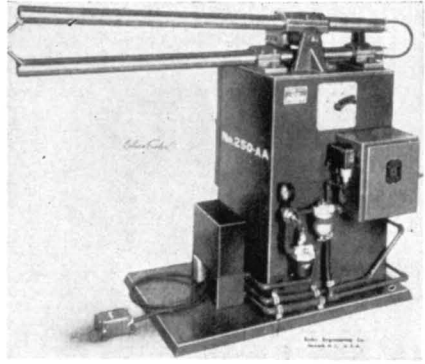
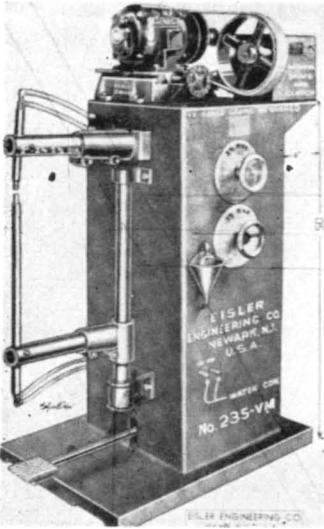

Left: The Eisler automatic motor-driven spot welder. (Patent No. 2,006,544.)
Right: The Eisler long-horn air-operated spot welder, adjustable for various sizes of spot welding with the 12" to 48" throat depth and long arms (15 to 75 K.V.A.). (Patent No. 2,231,617.)



A typical installation of Eisler spot welders used in making radio tubes at Sylvania in 1926.

1 1

It must be pointed out that not all of my designs were suitable for patenting. I was, however, continually on the alert for useful and needed innovations in my field of manufacture. In 1919, I was requested by a manufacturer to develop a nut which could be stamped from sheet metal,

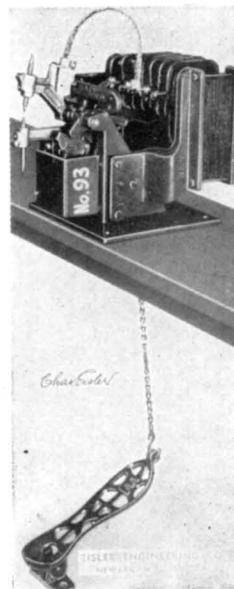
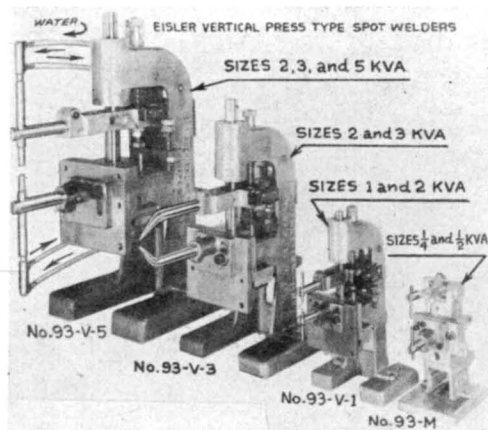
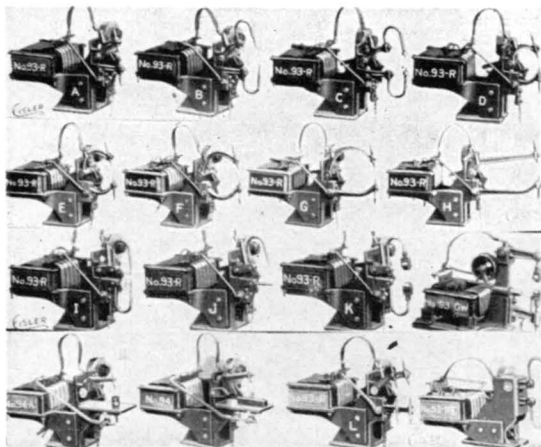

Above: (left to right) Spot welders, first made in 1912, are available in many types and sizes; the Eisler vertical press-type spot welders; a typical 1kva-Eisler spot welder. Left: The Eisler vertical-type spot welder with transformer and weld timer.

produced on power presses in volume by unskilled laborers. I was successful in producing such nuts (Patent No. 1,309,616,) but the market in general seemed unready for them. I should dislike having to estimate how many of them are

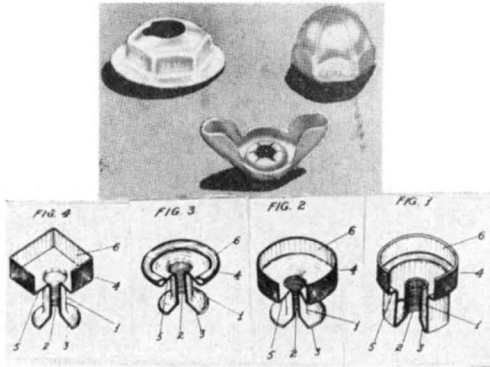

Nuts made of sheet metal stampings. (Patent No. 1,309,616.)

in use today—but a conservative estimate would place the figure well up in the billions.

Other Eisler-patented machines during the period include the glass bead machine (Patent No. 1,866,634) by which the

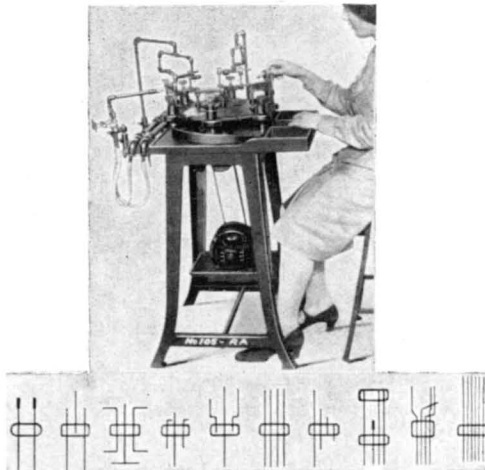

The Eisler glass-bead machine (Patent No. 1,866,634) and the various types and shapes of beads produced.

wire is imbedded in glass and the beads made from cut-glass tubing. Pressed beads may also be produced on the machine.

The automatic turntable (Patent No. 2,783,531) was produced in 1953, and was of great value in rendering more

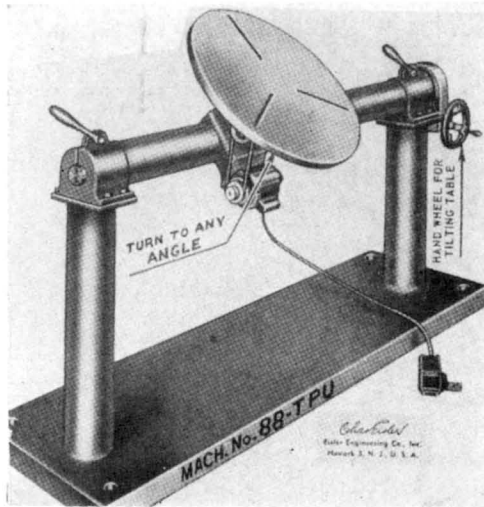

The Eisler automatic turntable. (Patent No. 2,783,531.)

efficient the process of arc welding. I contributed, as well, many improvements to high-vacuum pumps, the most important of which was the 1-piece body which resulted in a one-half reduction of individual parts. During one of my trips to Russia I was confronted with a concrete example of the esteem in which this development has been held. A young Russian factory engineer had taken some pages from an Eisler catalog, made an enlarged cross-sectional drawing of the pump's mechanism, and placed it on a large blackboard for general study. He was patiently explaining the function of the device to his fellow workers—men and women alike—as they sat eating their lunch during the noon hour. Practices such as these are indicative of the Russian technical propensity, and explain, in part, the tremendous Russian scientific advances of recent years.

The simplest inventions are, paradoxically, sometimes the most profitable and successful. Appended are a few of the relatively simple devices which I developed and sold by the thousands to lamp-makers in this country and abroad.

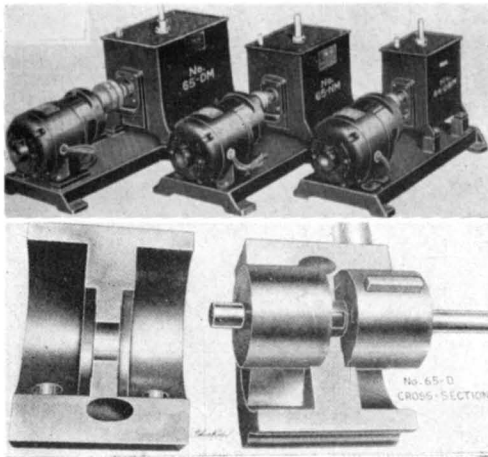

Above: Eisler high-vacuum pumps. *Below:* Cross-section of the housing of the two-stage high-vacuum pump.

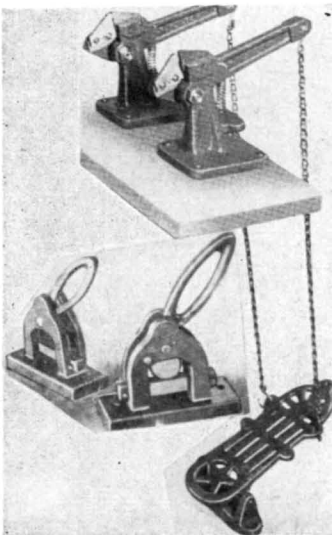

Above: The Eisler dual-foot clamber arrangement replaced the hand pliers, to greatly increase production. The first foot pliers appeared in Hungary in 1912 and at Westinghouse in 1914. *Below:* Exhaust tube pinch cocks.

PINCH COCK OR EXHAUST TUBE PINCH-OFF

The need for a quick and simple device to open and close the vacuum passage on trolley exhaust positions held my attention in 1912. The solution was elementary and certainly cannot be heralded as a feat of engineering. Nevertheless, the results proved so satisfactory that the device was universally adopted by lamp-makers; today, fully fifty years later, it is still in use.

GLASS-BLOWER SWIVELS

Swivels to prevent the tangling and twisting of the rubber tubing supplying and feeding gas, air and hydrogen to hand-operated burners employed by bench glass-workers in many glass-blowing operations came into being in 1912. These swivels have been continuously improved upon over a period of forty-eight years. The first popular swivels possessed

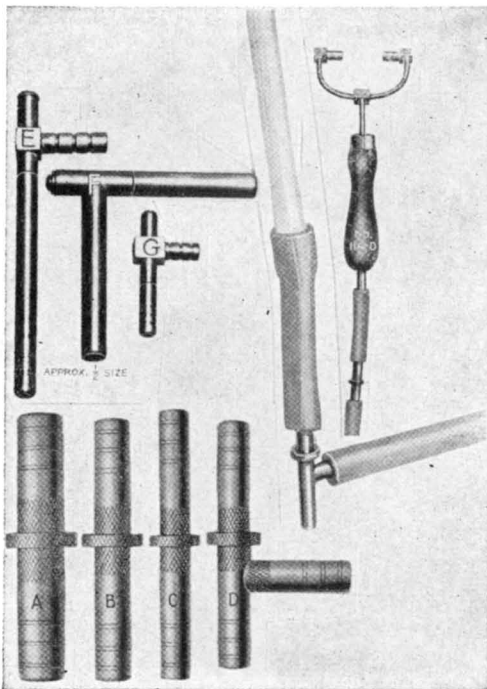

Glass-blower swivels, straight and offset. The application of the offset swivel shown right.

an adaptability for rotation, and were of incalculable benefit in stimulating speed and production.

In 1929 I patented a ribbon burner (Patent No. 1,704,349) for the neon-sign industry. It featured a fast shutoff valve. In 1931 I registered a similar ribbon burner (Patent No. 1,828,493) containing several improvements.

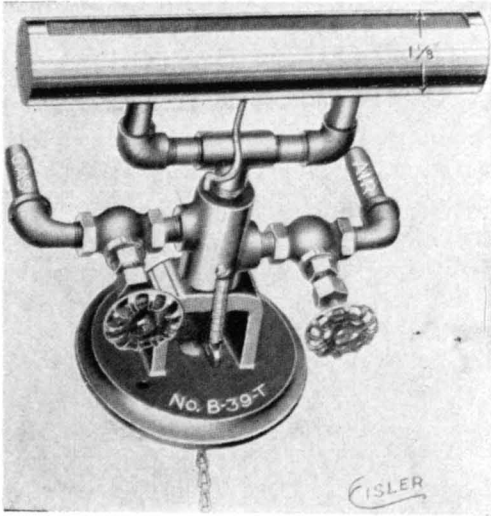

The Eisler ribbon burner (gas-air and also gas-air-oxygen).

GAS PURIFIER

Another of my inventions permitted the purification of gases under high pressure. It was never patented, and has been sold in quantity all over the world. As a matter of

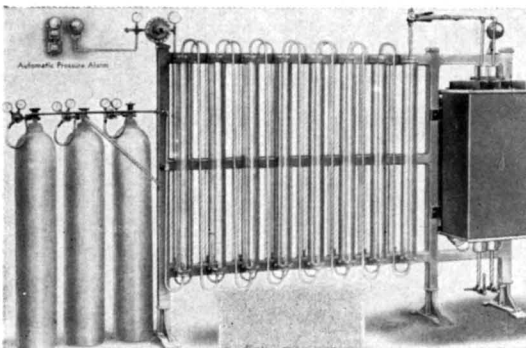

The Eisler gas purifier with automatic pressure alarm.

record, I should like to point out that the Eisler device was the first such purifier used by the small manufacturers who did not belong to the cartel and to whom information on the processes of purification was denied. The improvement in modern gases has, in many cases, obviated the necessity for this type of machine—though many of these purifiers are still in daily use by the manufacturers—but this was far from being the case years ago, when impure gases posed a genuine obstacle to the incandescent lamp industry and required additional purification to extract foreign gases detrimental to the life of the incandescent lamp. The Eisler invention, in use since 1919, was first used for nitrogen-hydrogen gases and, in later years, for the purification of argon gases. An important feature was the alarm bell which sounded when the gas pressure reached a dangerously low level.

SYRINGE-MAKING MACHINES

The Eisler new-type syringe machines are the fastest on the market, as well as the first of their kind in the syringe industry.

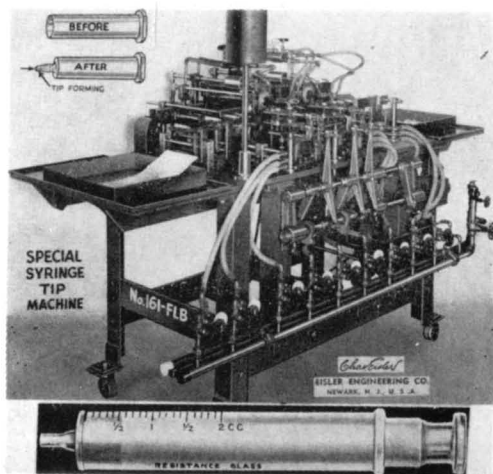

The Eisler automatic syringe tip-forming machine to shape the tip on the syringe barrel. (Patent No. 2,446,000.)

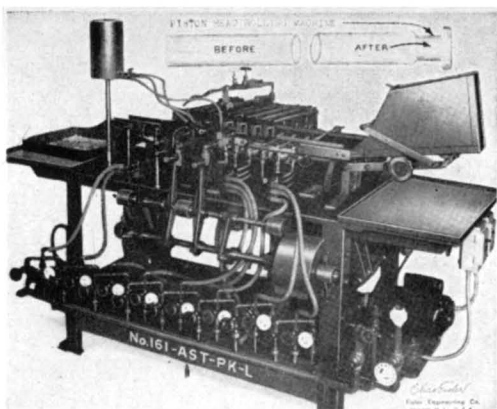

The Eisler syringe knob-forming machine.

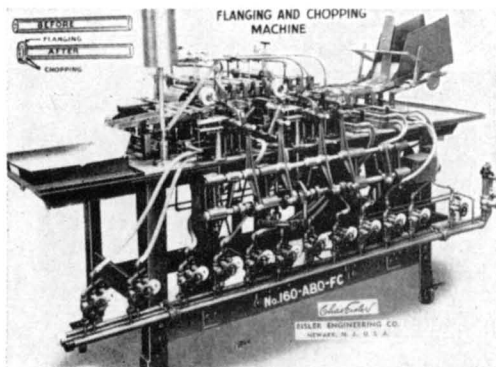

The Eisler syringe flange chopper, 1943. (Patent No. 2,445,000.)

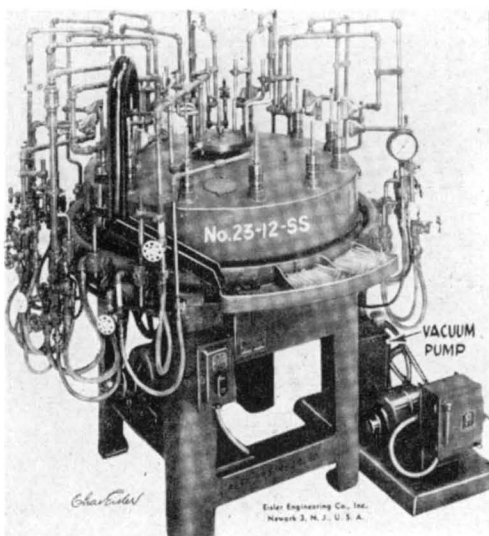

The Eisler 12-position syringe tube-shrinking machine, with Geneva-gear drive, air and oxygen burners, 1955. (Patent No. 2,779,135.)

AUTOMATIC LEAD-IN WIRE EQUIPMENT



The commercial wire products made by Eisler in 1920 were the first supplied to the independent lamp-makers.



Eisler's first automatic lead-in wire plant in 1923.

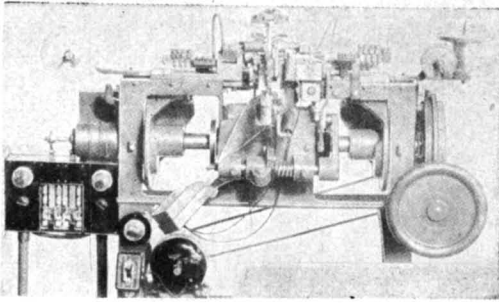

Automatic lead-in wire-welding machine made in 1919 by Bruckner of Germany. Eisler installed the machine for Save Electric Co. in 1920.

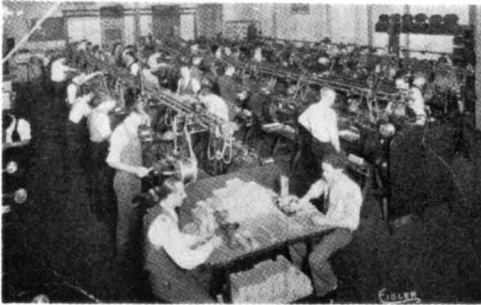

The largest automatic lead-in wire-welding plant in 1926 was owned and operated by Eisler.

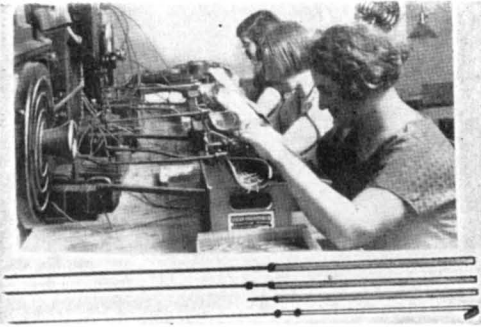

Eisler electric butt welders for lead-in wires were in 1921 the first such machines used by the independent lamp-makers.

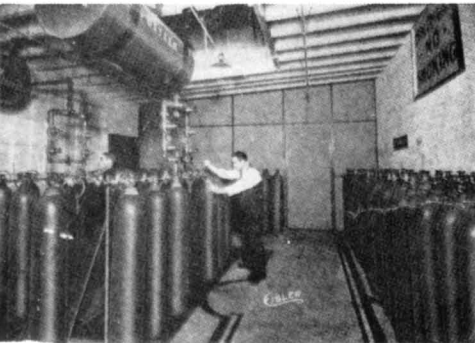

The Eisler hydrogen and oxygen tank room supplied the automatic lead-in wire plant in 1926.



A graphic portrayal of the evolution of the tube-making industry—from kerosene lamp to radio tube.

LIST OF PATENTS

A complete list of the Eisler-patented inventions, and the dates of their patenting, is appended below. Perhaps I may be forgiven a justifiable measure of pride in these accomplishments.

1,209,650	December 19, 1916	Turret Attachment
1,246,250	November 13, 1917	Adjustable Drill Head
1,309,616	July 15, 1919	Sheet Metal Device
1,635,316	July 12, 1927	Machine for Making Radio Tubes
1,324,886	December 16, 1919	Hot Swaging Machine
1,338,498	April 27, 1920	Filament-Winding Machine
1,338,499	April 27, 1920	Machine for Making Filament Supports
1,338,500	April 27, 1920	Machine for Making Lamp Stems
1,522,001	January 6, 1925	Machine for Making Electric Lamp Stems
1,553,309	September 15, 1925	Filament Coil-Winding Machine
1,635,316	July 12, 1927	Radio Tube Lamp Machine
1,637,989	August 12, 1927	Machine for Making Glass Mounts
1,655,050	January 3, 1928	Sealing-In Machine for Tubes and Bulbs
1,655,051	January 3, 1928	Stem-Making Machine for Incandescent Lamps
1,672,205	June 5, 1928	Compound Vacuum Pump
1,701,541	February 12, 1929	Construction of Incandescent Lamps
1,704,359	March 5, 1929	Gas Burner
1,741,016	December 24, 1929	Stem-Making Machine
1,819,597	August 18, 1931	Seal Exhaust Machine
1,828,493	October 20, 1931	Disc Valve for Burners
1,853,568	April 12, 1932	Burner
1,866,634	July 12, 1932	Bead Machine
1,874,575	August 30, 1932	Grid Winder
1,877,431	September 13, 1932	Beading Head Machine
1,936,426	November 21, 1933	Sealing-Off and Dumping Device for Exhaust Machine
1,972,719	September 4, 1934	Operating Mechanism
2,006,544	July 2, 1935	Welding Machines

2,063,235	December 8, 1936	Sealing Machine
2,063,236	December 8, 1936	Machine for Cutting Glass Bars and Tubes
2,078,630	April 27, 1937	Machine for Making Coils of Wire
2,087,104	July 13, 1937	Grill and Register Construction
2,093,147	September 14, 1937	Machine for Making Beads from Glass Rods and Tubes
(Des.) 116,840	September 26, 1939	Electric Welding Machine
2,321,617	February 11, 1941	Welding Machine, Adjustable Arms
2,266,417	December 16, 1941	Machine for Shaping Mouths of Glass Tubes
2,313,814	March 16, 1943	Conveyors for Glass Vials
2,409,423	October 15, 1946	Driving Means for Glass-Forming Machines
2,410,931	November 12, 1946	Tube-Cracking Machines
2,413,960	January 7, 1947	Machine for Sealing Glass Bulbs
2,414,587	January 21, 1947	Machine for Piercing Glass Bulbs
2,418,763	April 8, 1947	Machine for Sealing and Molding Glass
2,421,929	June 10, 1947	Machine for Sealing Bulbs
2,446,000	July 27, 1948	Machine for Flanging Glass Blanks
2,447,568	August 24, 1948	Machine for Forming Bottoms on Glass Tubes
2,447,569	August 24, 1948	Tubulating Machine
2,447,570	August 24, 1948	Bellows Clamp
2,470,923	May 24, 1949	Tube End-Forming Machine
2,534,547	December 19, 1950	Machine for Cracking and Flaring Blanks
2,553,135	May 15, 1951	Process and Machine for Vacuum Bottle Tubes and Piercing
2,553,136	May 15, 1951	High-Speed Tube or Cane Crack-Off Machine
2,593,999	April 22, 1952	Vacuum Flask-Sealing Machine
2,641,870	June 16, 1953	Continuous Tube Crack-Off Machine
2,683,331	July 13, 1954	Bulb-Stretching Machine
2,723,861	November 15, 1955	Centering Chuck
2,779,135	January 29, 1957	Tube-Shrinking Machine
2,783,531	March 5, 1957	Work Holder Turntable Mechanism
(Des.) 182,796	May 20, 1958	Spot Welder, Press Type

THE VITAL EVIDENCE

The important article and original drawings, referred to on pages 124-25 as "my strongest piece of evidence," was published in the December 1916 issue of *Machinery*, and is reproduced in its entirety on the following pages.

TUNGSTEN LAMP MANUFACTURE

PROCESSES USED BY THE UNITED INCANDESCENT LAMP CO., BUDAPEST, HUNGARY

BY CHARLES EISLER¹

THE processes used in the manufacture of tungsten lamps are of considerable interest. Owing to the fragility of the various materials used in the construction, the machines and fixtures must be so arranged that they will perform their functions in a minimum time and with little likelihood of breaking the parts. Practically every part of an incandescent lamp requires the most delicate handling, from the tungsten filament to the glass bulbs. The processes and machines described in this article are based upon the practice developed by the United Incandescent Lamp Co., Budapest, Hungary, and while this is not secret, the writer believes that this material has never been published in detail form in this country. The various steps which are taken in connection with the manufacture of the lamp from the swaging of the tungsten billet to the final testing of the finished lamp will be described in this article and the machines used will be illustrated.

Manufacturing the Tungsten Filament from the Slug

The powdered tungsten is first weighed and then poured

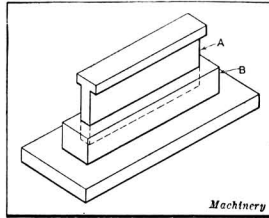

Fig. 1. Mold used for compressing the Tungsten Powder into Slug Form

evenly into a mold or die like that shown in Fig. 1, after which the mold is placed under a hydraulic press and compressed at a pressure of about 5000 kilograms per square centimeter. The die is made from high-grade tool steel, hardened and ground very accurately. The mold is usually made from $\frac{1}{4}$ to $\frac{3}{8}$ inch square and about 5 to 8 inches long. The depth of the die is considerably more than the slug is to be, in order to give the plunger A a good location in the die before the tungsten is compressed. After the bars have been compressed they are fragile and their handling requires skill. A hydrogen furnace is used

to unite these bars, the temperature being about 2000 degrees C.

Heating and Swaging the Slug

A special electric furnace such as that shown in Fig. 3 is used to heat the slug to a temperature of from 1200 to 1300 degrees C. in an atmosphere of hydrogen. Referring to Fig. 2, the various parts of the tungsten lamp will be seen, and the form produced on the tungsten slug by the first swaging operation can be noted at A. One end of the slug is formed for a distance of 80 or 90 per cent of the length, after which it is

¹ Address: 43 Dodd St., Bloomfield, N. J.

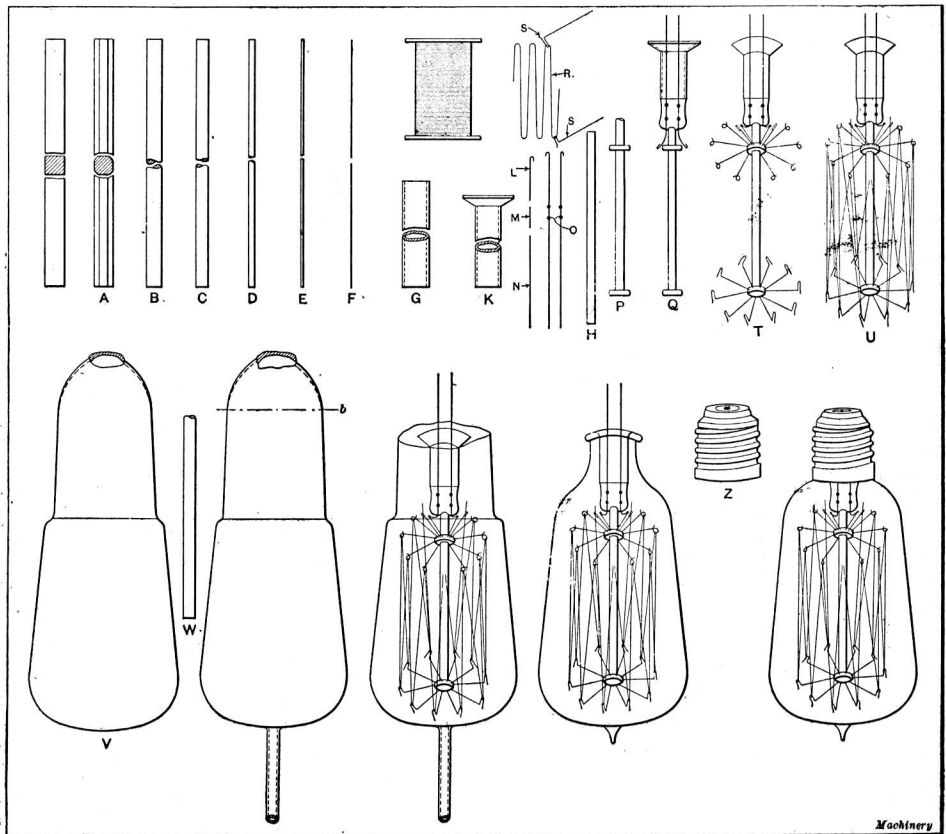

Fig. 2. Component Parts of Tungsten Lamps

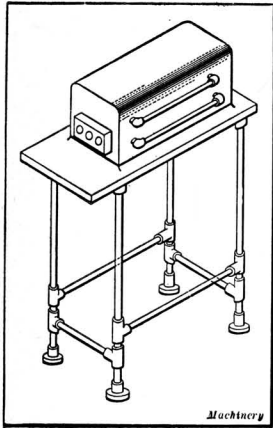

Fig. 3. Electric Furnace used for Slug Heating

reheated and the other end swaged to completion. The handling of the slug from the furnace to the swaging machine is done very rapidly in order to prevent the slug from oxidizing as far as possible.

Hot-swaging the Slug

After the slug has been heated to the proper temperature, it is removed by means of the pliers shown in Fig. 5 and transferred to the swaging machine for the first operation, which consists of forming it into octagonal shape. Fig. 4 shows a hot swaging machine built by the Langelier Mfg. Co., Providence,

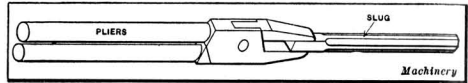

Fig. 5. Pliers for holding Tungsten Slug while swaging

rim and acts as a flywheel, producing a steadier movement. As the spindle revolves, the jaws are thrown outward by centrifugal force, so that the outer ends strike against the steel rolls *D*, which throw them back again toward the center. There are a number of these rolls on the inside of the cage so that the reciprocating action of the jaws is very rapid. This type of machine was described in detail in the January, 1914, number of MACHINERY on page 420.

Fig. 2 shows at *A, B, C, D, E* and *F* the various steps through which the tungsten slug passes in being swaged to the required size. The rods are swaged from 5/16 inch square to 1/32 inch round in steps of about 0.020 to 0.025 inch at a time. When the rod has been swaged to 1/32 inch, it is usually from

R. I. These machines are built in several sizes, the same principles being incorporated in the various machines, with the exception that in the case of the No. 1 1/2 hot swager, there is an annular recess or chamber inside the machine head, through which a stream of cooling water is kept running in order to prevent the machine from heating unduly during the handling

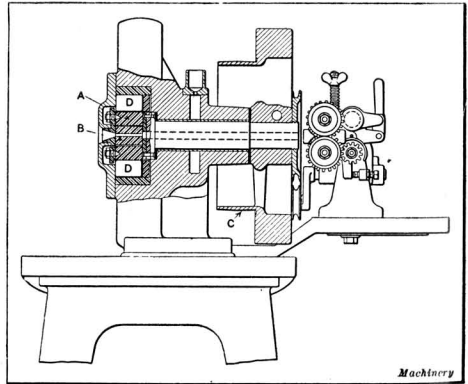

Fig. 6. Longitudinal Section through Head of Langelier Swaging Machine

75 to 100 feet long. From 1/32 inch, the wire is drawn at a cherry red through diamond dies by steps of 0.002 to 0.005 inch until it is about 0.003 inch outside diameter. For the smaller sizes it is drawn by steps of 0.001 inch down to 0.001 inch outside diameter, or even smaller if required. Wire has been drawn down to 0.0004 inch outside diameter and to lengths of from 10,000 to 11,000 feet.

Drawing Wire Through Diamond Dies

After the swaging operations have been performed, the wire is drawn through diamond dies as shown in Fig. 7. The drawing operations are performed on several sizes of machines.

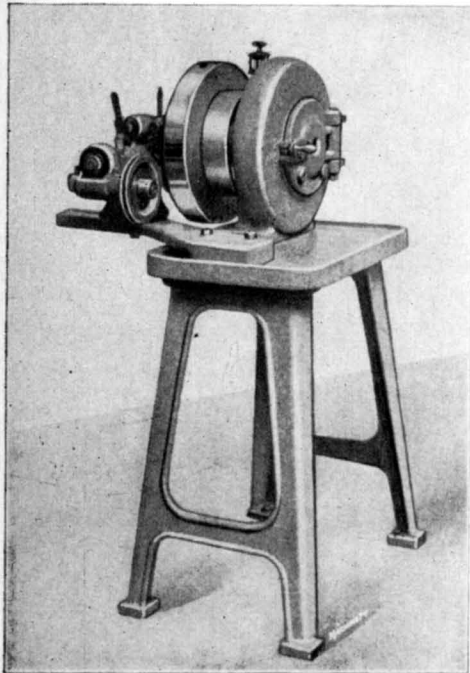

Fig. 4. Langelier Swaging Machine

of the hot tungsten wire. The sectional view shown in Fig. 6 is taken directly through the center of the spindle and shows the construction very clearly. The spindle is slotted across the enlarged end to receive a pair of hammer-blocks and dies *A* and *B*, the reciprocating action of which is in a radial direction. The spindle is driven by the pulley *C*, which has a heavy

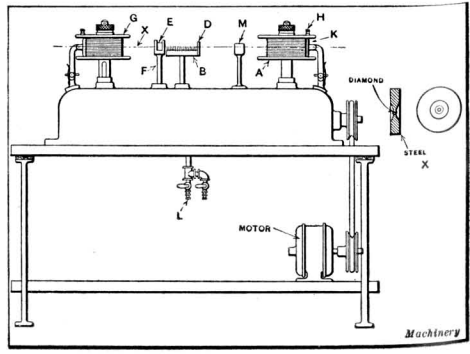

Fig. 7. Machine used for drawing Tungsten Wire through Diamond Dies

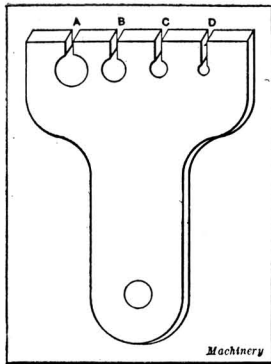

Fig. 8. Gage for Glass Tubing

evenly on it. The end of the wire is held on the spool by the screw *H*, and the protector *K* is provided to keep the wire on the spool in case it should break during the drawing operation. The wire is heated to a cherry red heat while being drawn, the gas and air mixers at *L* being provided for this purpose; these supply the gas for the burner *B*.

Cleaning and Flashing the Wire

The wire is now cleaned and annealed under hydrogen by the machine shown in Fig. 9. It is taken from a spool at

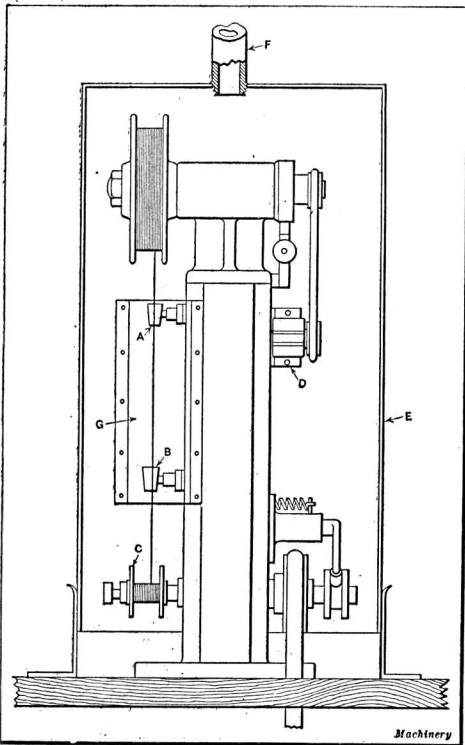

Fig. 9. Machine used for cleaning Tungsten Wire

the top, drawn through the mercury cups *A* and *B* onto the spool *C*, which is passed back and forth to allow the wire to be distributed evenly on its surface. A speed recorder *D* shows

according to the diameter of the wire. The wire is drawn at the rate of from 10 to 85 feet per minute, the speed depending on the size of the wire. The operation is as follows: The wire is placed on spool *A* and led through lubricator *M* and guide *D* over gas flame *B* and through die *E*. This die is held in a bracket *F* and the wire *X* is wound on the spool *G*. This spool travels vertically up and down a distance equal to the width of the spool, in order to distribute the wire

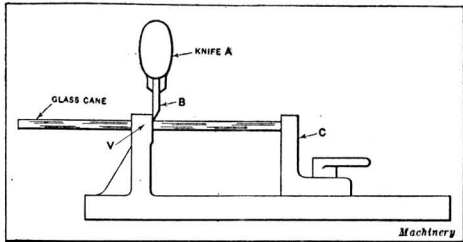

Fig. 10. Cutting Glass Tube on Hand Fixture

the number of meters which are run from each spool. The machine is covered by a hood *E*, which contains hydrogen gas and is provided with a mica window *G* so that the operator can observe the working of the wire.

The mercury cups *A* and *B* form the terminals through which an electric current passes which heats the wire in

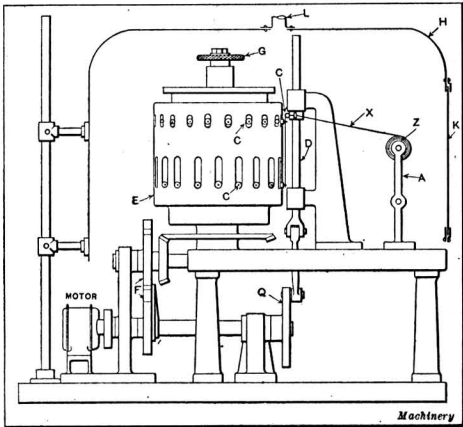

Fig. 11. Forming Zigzag Filament

transit, and while this is being done it must be run under hydrogen in order to keep it from becoming oxidized. This process of heating the wire electrically as it passes through the mercury cup is called flashing. The hydrogen is let into the hood by the inlet pipe *F*, and provision is made for raising and lowering the hood by means of a sprocket chain and hand-lever not shown.

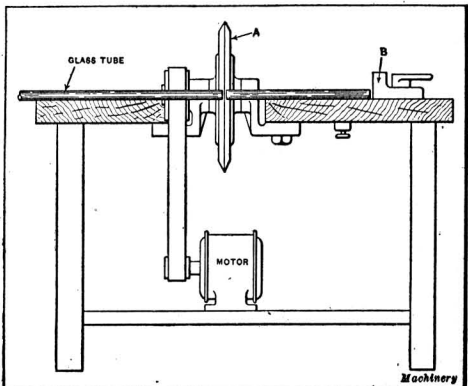

Fig. 12. Cutting Glass Tube with Emery Wheel

Forming the Zigzag Wire

A special forming machine shown in Fig. 11 is used to form the wire into zigzag shape after it has been cleaned as described in the previous operation. The process is as follows: The spool *Z* is filled with wire and placed on the bracket *A*. The wire *X* is bent over the pins *C*, which are adjustable for different lengths of the zigzag. The machine is driven by the electric motor shown through a stop motion of the Geneva type shown at *F*. The wire is drawn from the spool through a holder on the sliding rod *D* controlled by the eccentric shown at *Q*. Adjustment is obtained by turning the knurled nut *G*. The pins *C* are insulated to give the proper electrical contact, as the shape of the wire is formed while it is red hot. The mechanism is covered by a sheet metal hood *H* having a mica opening at *K* to permit the operator to see the work. The operation is performed under hydrogen as in the preceding case, the gas entering the hood at *L*. The tungsten wire is

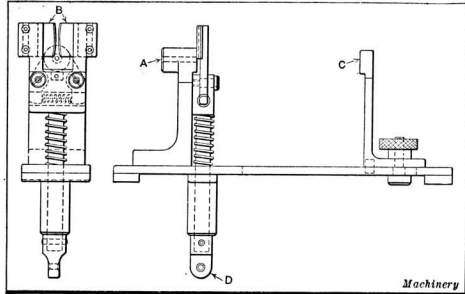

Fig. 13. Machine Fixture for cutting Glass Tube

shaped under the hydrogen hood in order to prevent the filament from oxidizing. The hood can be raised by means of a chain and handwheel.

Cutting the Glass Tube

Several methods of cutting the glass tubes are in vogue, but the operation of cutting is very simple. The tube shown at *G* in Fig. 2 is cut on an ordinary rotating wheel as shown in Fig. 12. A V-shaped carborundum wheel *A* is used and the tube held against the stop *B*, which is adjustable for various lengths. The operator can handle more than one length of glass when cutting by placing one on top of the other. It must not be understood that the glass is entirely cut through by the wheel, as it is simply nicked a little and then cracks off, due to the heating action of the wheel on the glass. The tubes are cut from lengths of about three or four feet, and with this method 2500 to 3000 can be cut per hour. The glass cane shown at *H*, Fig. 2, can also be cut by this method, but another device is used for the solid glass rods.

Fig. 10 shows a hand fixture used in cutting the glass rod *H*. The cutting in this case being done by a knife. The most common type of knife in use is that shown at *A*, although others are being used to some extent. The knives are made of special tool steel and hardened. When regrinding, they must be ground on stones under a stream of water, in order

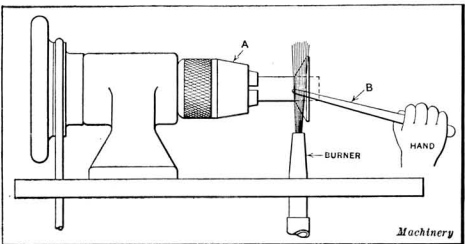

Fig. 14. Flanging Glass Tube to make the Flare

to guard against the temper being drawn in the slightest degree.

The knives shown at *B* in Fig. 13 are used in a fixture in which the glass rod is fed through the hole *A* and is held against the adjustable stop *C*. The knife blades are then pulled down by the plunger *D* by means of a foot-treadle not shown in the illustration. By this method the glass is scratched on both sides and then cracked off. From 2000 to 2500 pieces per hour can be produced in this way by a girl. In sorting, a regular snap gage is used such as that shown in Fig. 8. This work is done before the tubes or canes are cut to the required length. About eight or ten rods or tubes can be held in the operator's hand at one time and gaged very rapidly. At *A*, *B*, *C* and *D* are shown the slots for the different sizes.

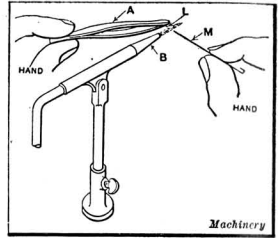

Fig. 15. Welding Tungsten and Platinum Wires

Making the Flange

The glass tube *G*, Fig. 2, is heated in a special rotary chuck *A* shown in Fig. 14, and when the glass has been heated to the proper temperature it is flanged by the rod *B* to the shape *K*.

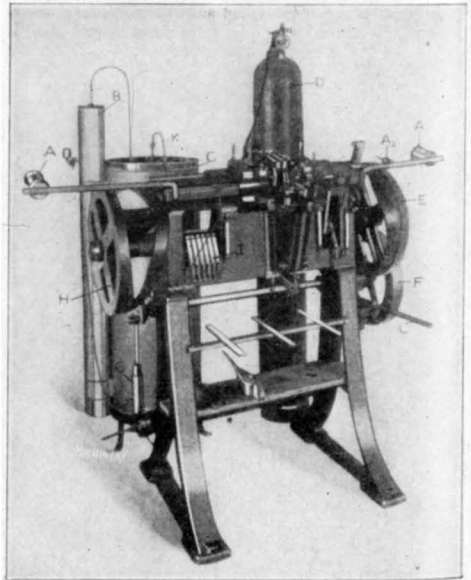

Fig. 16. Automatic Machine for welding Lead-in Wires

Fig. 2. In the majority of cases two or more rotary chucks are used so the maximum production will be obtained. When two chucks are used, one is being heated while the other is being loaded. The forming is generally done by hand, but may be done automatically if desired.

Making the Lead-in Wire

Referring to Fig. 2, *L* is a nickel lead-in wire of which one end is bent and clamped to the filament and welded to *M*, which is made from platinum or a substitute. This portion is usually 1/8 inch long and has a diameter of 1/64 inch approximately, depending upon the size of the lamp. Platinum is used because it has the same coefficient of expansion as the glass. *N* is a copper wire, the ends of which are soldered to

the base after the lamp is based. The wires *L*, *M* and *N* are electrically welded together as shown at *O*, and two are used in each lamp. It is an interesting fact that the majority of lamps of this kind contain platinum, and up to the present time it has been difficult to procure any substitute.

In making the welds on pieces *L* and *M*, the part *L* is held with a pair of tweezers *A*, as indicated in Fig. 15, while the part *M* is held by hand, and both ends are brought together over the needle gas burner *B* and welded. This operation looks difficult, but an operator with little experience can get a production of approximately 350 pieces per hour. The part *N* is handled in the same manner.

Fig. 16 shows a machine which is a standard product of a German manufacturer for welding lead-in wires. This machine is arranged to take three different kinds of wires and

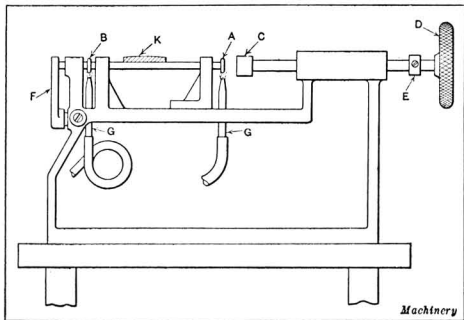

Fig. 17. Fixture for making Cane Rod Buttons

weld them into one complete unit, the production being in the vicinity of 2500 pieces per hour. It can be arranged to make hooks or tubes as desired. Referring to the illustration, *A*, *A*, and *A*, are, respectively, the copper wire roll, the nickel wire roll, and the platinum wire roll. The gas regulator and the gas tank are shown, respectively, at *B* and *C*, while the hydrogen bottle can be noted at *D*. The driving pulley and flywheel are shown at *F*, and the gear and cam by means of which the slides are operated are indicated at *E*. The gas compressor *G* is driven from the main shaft. The electrical contacts are at *I*. The movement of the slide is controlled by the cam wheel *H*.

Making the Cane Rod Buttons

The glass arbor or cane rod shown at *H* in Fig. 2 is cut to length and sorted to the proper size, as previously described. After it has been cut, the rod is inserted in the fixture shown

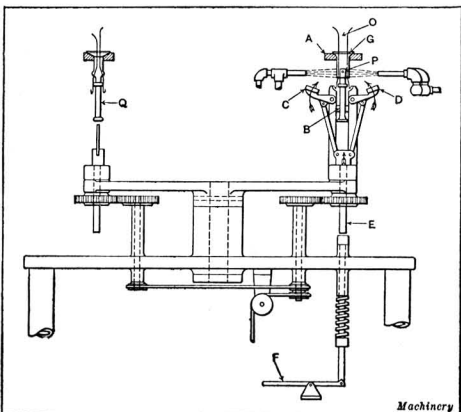

Fig. 18. Machine for making Stem

in Fig. 17, in order to make the buttons or enlarged ends as shown at *P* in Fig. 2. The glass rod is located in U-grooves and the flames *G* heat the part where the button is to be made. After sufficient heat has been applied, the end of the rod is pressed by hand by the knurled knob *D* and the anvil on the end of rod *C*. An adjusting collar is provided at *E* and another adjustment for the other end may be noted at *F*. While the rod is being heated, it is turned back and forth by a fiber turner *K* to form the button to the required shape. Other methods are used for doing this work, but the process shown produces good results and is inexpensive. Five or six arbors can be handled at one time, and the anvils can be arranged to be operated by a foot-lever if desired.

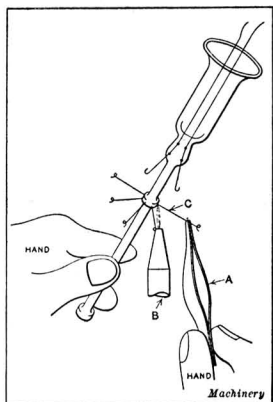

Fig. 19. Inserting Anchor

Stem Making

A complete stem consists of parts *K*, *O* and *P*, Fig. 2, which are assembled to make the piece *Q*. The flare, lead-in wires and arbor are inserted in a holder as shown in Fig. 18. The flare is held in a sort of nest and the arbor by the jaws shown at *B*. While the welding flames are softening the glass parts the head is rotated, and after the glass has been softened suffi-

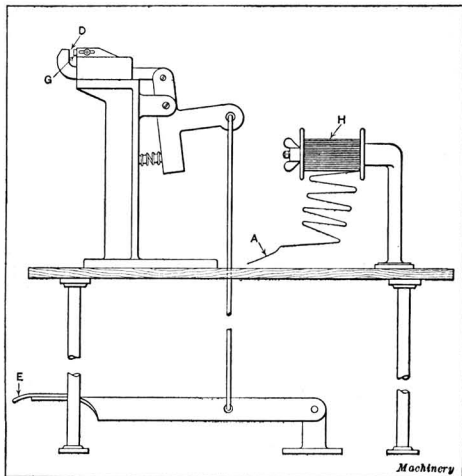

Fig. 20. Fixture for clamping Zigzag Filament to Lead-in Wires

ciently the clamping is performed by the jaws *C* and *D* and the plunger *E*, actuated by the foot-lever *F*. Machines of this type frequently have from one to eight separate heads. After this operation has been performed, the stem is ready for the insertion of the filament supporting anchor.

Inserting the Anchor

The anchor is made of nickel wire and the end is coiled on a special machine at the rate of 5000 per hour, after which the wire is inserted in the stem as shown in Fig. 19. The flame from pipe *B* is directed against the button and anchor *O* while the nickel wires are set in place by tweezers *A*, a

needle burner being used for this work as previously described. A part of the hub and the short end of the anchor *C* are heated and inserted by hand, as indicated.

Mounting the Zigzag Filament

The zigzag filament shown at *R* in Fig. 2 is taken from a drum and mounted on hooks as shown at *S*; in addition, the two ends of the tungsten wire are clamped to the lead-in wires

ed. This operation is done when the wire is taken off from the forming machine shown in a previous illustration. The spool *H* is conveniently accessible to the operator, so that the work can be done very rapidly. It will be understood that the work shown in Fig. 21 of pressing the zigzag filament on the anchors is done after one end of the wire has been clamped, as stated.

Operations on the Bulb

After the bulb shown at *V* in Fig. 2 comes from the glass molds, it is first washed. The piece shown at *W* is the so-called top tubing which has been cut and sorted to the proper size. This tubing is cut into three-foot lengths by the same process as was employed for cutting the glass canes.

Piercing the Bulb

Before the top tubing *W* is sealed on the bulb, it is necessary to pierce a hole as shown at *X* in Fig. 23. The method of piercing this hole is clearly shown in Fig. 22. The bulb *A* is placed in the nest *B*; the cap *C* is lowered, and the rubber ring *D* acts as a seal on the bulb. *F* is the air inlet to

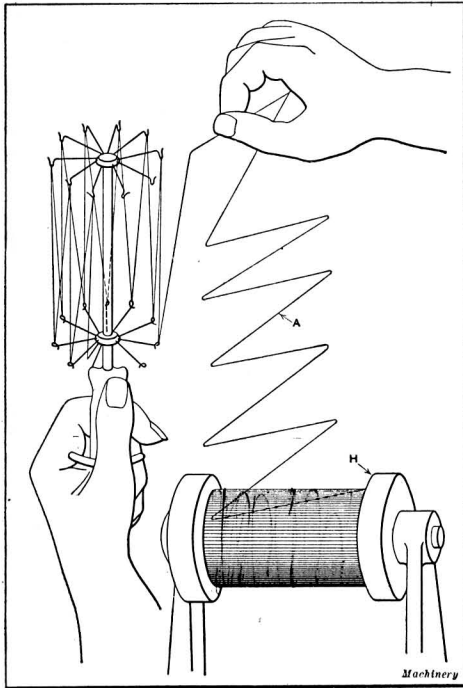

Fig. 21. Method of assembling Zigzag Filament

as shown at *U*. In this operation the zigzag wire is removed from the spool on which it has previously been wound, as indicated in Fig. 21, and hooked over the anchors by hand.

After this has been done, the operator takes the end of the wire *A* and holds it in the hooked end of the lead-in wire while this is placed between the jaws *D*, Fig. 20. By pressing down on the lever *E* the jaws are moved together to clamp the wire in place. After one end has been clamped, the operator winds the zigzag on the hooks, clamps it and cuts off the end at the same time with a knife. During this operation the work is held at a slightly different angle. It will be noticed that the zigzag wire has already been wound on the spool *H* into the V-shape that it will have when mount-

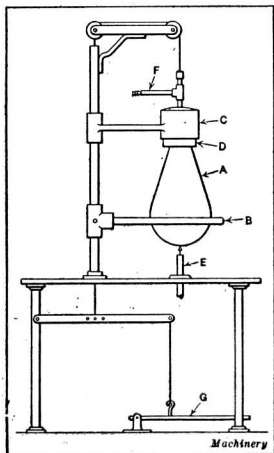

Fig. 22. Piercing Bulb

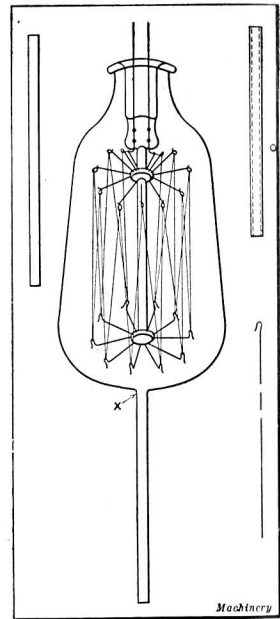

Fig. 23. Bulb with Tube and Stem assembled

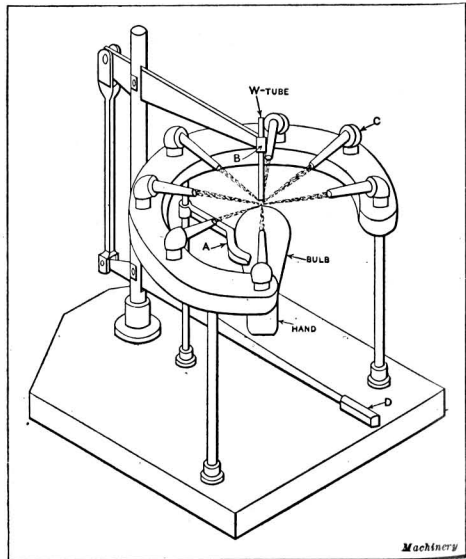

Fig. 24. Tubulating Bulb

which a rubber tube is connected when in operation. The air enters the bulb while the flame heats the part where the hole is to be pierced. As soon as the glass has become soft from the gas flame *E*, an opening is caused by the air pressure,

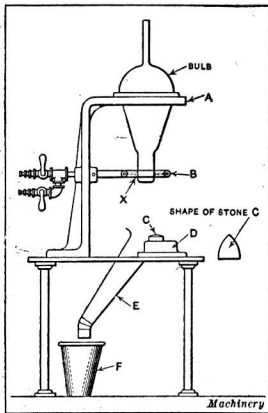

Fig. 25. Cracking off Collar

lever *D*. This lever is connected with the burners *C* in such a way that as soon as the lever is touched the flames stop burning. During the course of the operation, the bulb is turned back and forth a little until it is sufficiently hot to make the seal.

Cracking Off the Collar

The apparatus used for cracking off the bulb collar is shown in Fig. 25. The bulb is placed in the fixture *A* and the part to be cracked off at *X* centers in a ring burner which heats the bulb all around. Then the bulb is removed and the end *X* is placed on a saturated stone such as that shown at *C*, or on any other substance which will hold moisture. As soon as the

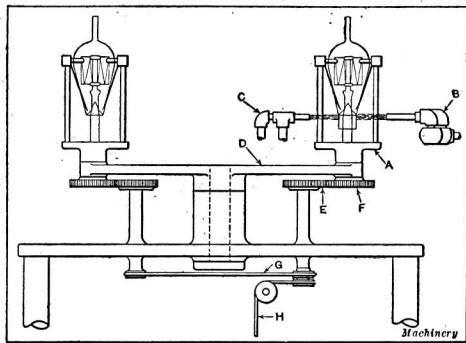

Fig. 26. Sealing Bulb

hot glass strikes the stone the collar breaks off, leaving a clean fracture. *D* is the water container intended to supply the moisture, *E* is a chute for scrap, and *F* is a scrap pail. In operating, the bulb is held on the stone *C* until it cracks off, the operator in the meantime having placed another bulb in the holder *A*, making the operation almost continuous. About twenty to twenty-five seconds is the time taken to perform this operation. The top tubing is used to locate the bulb during the operation of exhausting.

Sealing the Bulb

The bulb and stem are located in a rotating holder as shown at *A* in Fig. 26. While this is rotating, the two segmental fires (Bornkessel) *B* and *C* heat the bulb until both parts are melted together as shown. There are usually four or more arms or heads *D*, so that the bulb can be heated gradually and the finished bulb allowed to cool while one position is being finished. The holder or head *A* is rotated by the gears *E*

after which the cap *C* is raised by removing the pressure from the treadle *G*. The air pressure used is from 4 to 5 pounds per square inch.

Tubulating the Bulb

The tube is inserted in the bulb on a machine shown in Fig. 24. The bulb is held by hand in the nest or case *A* while the tube is held by a spring chuck *B*. The flames *C* must concentrate on the center of the bulb and on the end of the tube, and when both parts are heated to the melting point the tube *W* is pressed lightly against the bulb by the hand-

and *F* driven by the belts *G* and *H*. The operator always remains in the same position in relation to the holder. When the work is completed, the operator simply turns the arm *D* by hand for the next position. Automatic attachments for indexing are also made for machines of this kind.

Exhausting the Lamp

The method of exhausting the lamps is shown in Fig. 27. The lamps *B* are inserted in the rubber tubes *C*, and the lead-in wires are wrapped around pins *A* through which an electric current passes. The tubes *C* are on a common manifold which is connected to the vacuum line *D*. After the lamps have been placed in their proper position, they are raised into the oven *E* which is kept hot by gas flames. The oven temperature is raised to as great a degree as the lamps will stand without damaging them, and they are left here for a short time, after

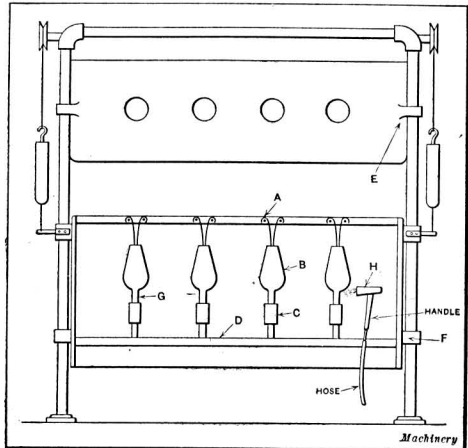

Fig. 27. Apparatus used for exhausting Lamp

which they are lowered again and burned at about 120 per cent rating for four or five minutes.

After this the lamps are tipped off, that is, the tube *G* is cut off with a hand torch as shown at *H*, and then removed for other operations. The vacuum obtained varies according to the size of the bulbs and the shape of the lamps. A high vacuum of 0.001 millimeter, mercury pressure, is obtained in some cases. In any event, the vacuum must be as perfect as is commercially possible.

Basing the Lamp

The bases shown in Fig. 2 at *Z* are filled with cement and placed on the bulbs, after which they are located in the basing fixture as shown in Fig. 28. There are two separate carriages

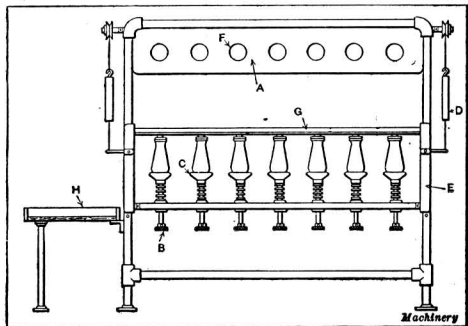

Fig. 28. Basing Lamp

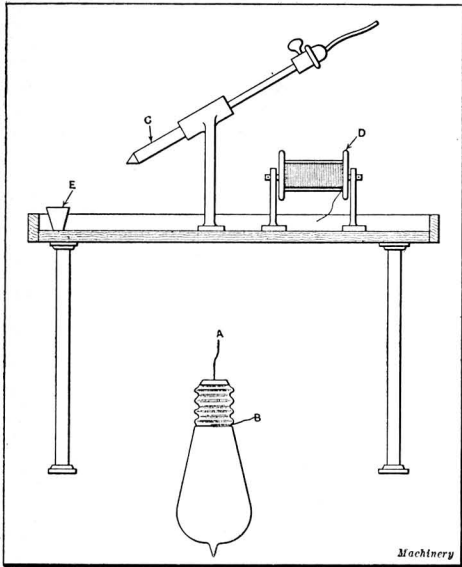

Fig. 29. Soldering Lead-in Wires

on which the bulbs are placed, only one of which is shown in the illustration, the other being in the gas oven shown above. It will be noticed that all the lamps are in a line, so that the operator can easily determine whether they are set up straight or not. In operation, the base and lamp are held by the plunger *B*, and the cone cup *C* is held in position by the coil spring shown. Weights are provided at *D* to balance the slide or carriage *E*. The oven is provided with holes *F* covered with mica so that the operator can see that the lamps are not being overheated. The portion *G* acts as a guide for the Edison bases, and *H* is the table on which the operator works while the lamp bases are backed on the lamps.

Soldering the Lead-in Wires

After the Edison sockets have been baked on the bulbs the lead-in wires project from the base as shown at *A* and *B* in Fig. 29. An electric soldering iron *C* is used for soldering

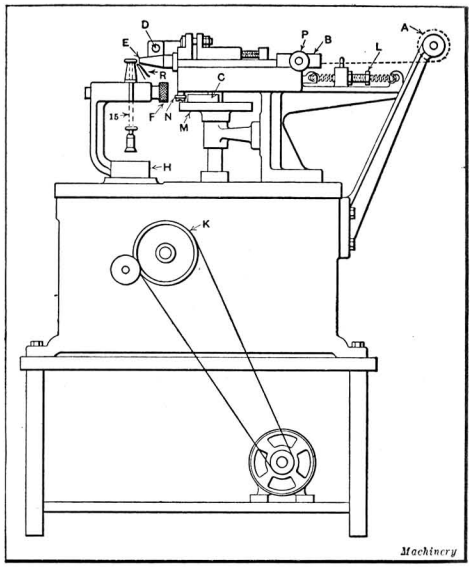

Fig. 30. Machine used for inserting Hook End of Nickel Wires

these wires, the iron being stationary while the lamp is held in the correct position for both *A* and *B*. The solder is in wire form on a spool *D*, a soldering paste box being provided at *E*. After the soldering operation, the projecting wire is cut off by a special knife.

The socket is now polished on a regular polishing wheel in order to clean it perfectly, the polishing wheel being located very close to the soldering fixture.

Inserting the Hook End

The inserting of the hook end of the nickel wires is done by means of the special machine shown in Fig. 30. The wire is drawn from the spool *A* and straightened at *B*, being carried from the straightener by a slide. The forward movement of the slide is governed by the cam *C* and the roller *N*. On the return stroke, guide bushing *E* stops, and knife *D* cuts the wire, actuated by cam *M*. Bracket *H* rotates and stops at

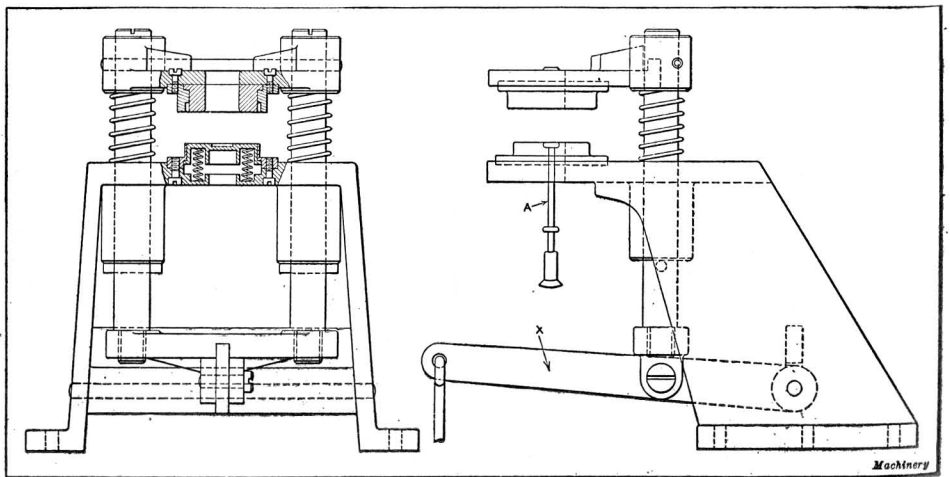

Fig. 31. Machine used for bending Hooks when inserted

certain intervals to give the proper spacing for the hooks. This movement is effected by a Geneva motion. The length of stroke can be regulated by the adjusting screw *L* while the straightener is regulated by the screw *P*. *F* is the thumb-screw used to open the jaws for loading and unloading, and *K* is the driving pulley. The position of the needle flame is shown at *R*. After the hooks have been inserted they are bent by the fixture shown in Fig. 31, the stem being inserted in the bending die as shown at *A* and bent by pressure on the foot-treadle which is connected to the arm *X*, thus operating the plunger carrying the die. A fixture of this kind is used for bending wires from 0.010 to 0.014 inch outside diameter. When the wires are from 0.003 to 0.005 inch outside diameter, a different type of fixture is used as indicated in Fig. 32. The construction of the fixture is simple, and the operation will be apparent by reference to the illustration; it will be seen that the device is hand-operated.

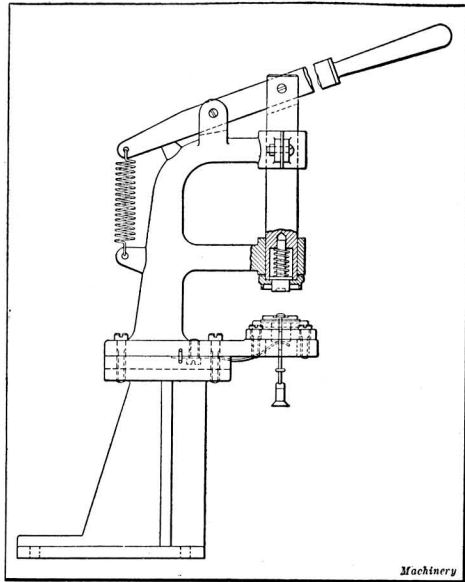

Fig. 32. Hand Fixture for bending Small Wires

Bump-testing Operation for Lamps

In order to see how long lamps will last under current while being vibrated and knocked against, the lamps are given a durability test so that it can be determined whether they are suitable for use on street cars or other vehicles having considerable vibration. Referring to Fig. 33, it will be seen that the lamp is placed in a regular socket on the rod *A*, through which electric wires are passed to furnish the necessary current for lighting the bulb. The fixture can be turned into any position, being pivoted at *F*, so that the lamps can be burned when they are tipped up, tipped down, horizontal or at any other angle while burning or vibrating. The cam *C* revolves at the rate of from 100 to 225 R. P. M. and causes the shoe *D* to move up and down and to drop off the shoulder on the cam, thus allowing the rod *A* to fall until it strikes the adjustable stop *E*. The position of this stop determines the amount of "bump," and it is evident that various settings can be easily obtained. This is one of many methods used for testing the durability of lamps. After the stems and lamps have been finished, they are loaded on special trays, as shown in Fig. 34, which are made so that they can be placed on top of each other and easily handled by the projecting ends *B*. The bulb and stem trays are of similar construction except

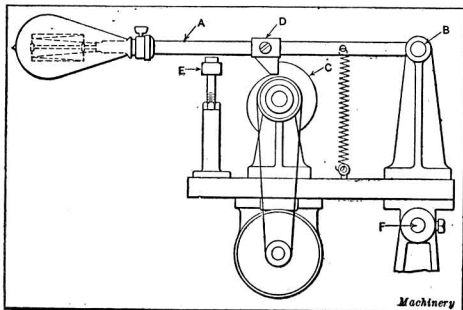

Fig. 33. Machine used for bump-testing Lamps

that the bulb trays are provided with holes as indicated, while the stem trays have fiber pegs as shown at *C*.

It will be seen from the foregoing description of the methods of manufacturing tungsten lamps that every operation which can be, is handled by an automatic machine, while for operations of such a nature that a machine is not practical, special tools or fixtures of many kinds are devised to make the lamp manufacturing cost very low. In addition to the operations mentioned, there are tests of burning the finished lamp, inspecting operations, etching, labeling, boxing, etc. Also in addition to the "bump" test mentioned in the article, the lamps are burned for "life" tests. The "bump" tests used are of different kinds; sometimes an entire box of lamps is rolled from the top of a three-story building to the basement, and if the lamps do not break under this severe test, it shows that they are suitable for use in

street cars and other service of similar nature, and that they can be shipped with safety to any part of the globe. The output of the Hungarian factory in which these processes were developed is from 25,000 to 28,000 lamps of every kind per day.

A great deal of statistical matter has been published on the amount of iron ore known to be available, and it is generally believed that the United States Steel Corporation controls the greatest amount of tonnage available in the Western hemisphere. This is not true. The Nova Scotia Steel & Coal Co. owns the Wabana mine on Bell Island in Conception Bay, Newfoundland, in which it is estimated there is between 2,000,000,000 and 3,000,000,000 tons of hematite ore. The deposit is probably more than double the holdings of the United States Steel Corporation, which are estimated to be about 1,300,000,000 tons. The quality of the ore is very rich, averaging 51 to 53 per cent pure iron in the three seams worked. Bell Island is only two miles wide by six miles long, but mining operations are being carried on beneath the sea, the holdings of the company in fact being greater beyond the shore lines of the island than on the island itself.

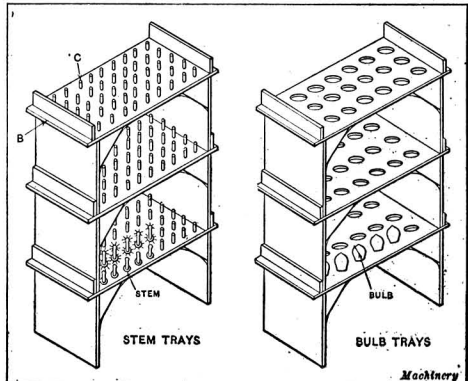

Fig. 34. Stem and Bulb Trays for Lamps

THE MILLION - DOLLAR BEND

THE AUTOBIOGRAPHY OF THE BENEFACITOR
OF THE RADIO TUBE AND LAMP INDUSTRY

CHARLES EISLER, M.E., D.S.C.

(continued from front flap)

course of the independent lamp-making industry. That Eisler's original machines had been designed in Hungary long before he came to the cartel was proven to the satisfaction of the federal courts, and the cartel found itself in the unprecedented position of having been bested by a single small manufacturer.

It is no exaggeration that Eisler's victory exerted a profound and far-reaching influence on the anti-trust legislation and actions that followed this historic case. Dr. Eisler makes no secret of his satisfaction in organizing the independent manufacturers into an association strong enough to assure that the lamp field would remain open. His company catalog has become the "bible" of the industry, and this book's appendix—a description of the hundred-odd Eisler inventions—is a veritable textbook for the lamp industry.

Looking back now that he is in his seventies, Dr. Eisler narrates the incidents of his childhood and his full life in the United States, the tragic fate of most of his brothers and sister under the Nazi terror, his travels abroad and his estimate of the social and economic scenes—all with a resounding candor and a wealth of photographic material. His book stamps him as one of those to whom the world belongs—not because they subdued it, but because they love it.

THE WILLIAM-FREDERICK PRESS
391 EAST 149TH STREET
NEW YORK 55, N.Y.



Charles Eisler at the age of seventy-two, in 1956.